

TRU-TURF
ROLLING PERFECTION



OWNERS MANUAL

RB48 GOLF GREENS ROLLER
Original Instructions

EU Authorised Representative:

VeriSafe Compliance Ltd.

77 Lower Camden St

Dublin

DO2 XE80

Ireland

Original Instructions

The products detailed in this manual conform to the following standards:

Machinery Directive 2006/42/EC, EMC Directive 2014/30/EU & EN ISO 4254-1:2015

CE Declaration available at www.truturf.com

Manual Revision: B

Change Description: Manual updated to CE cert level.

Released: 12/08/2023

Table of Contents

1. [Machine Information Record](#)
2. [Specifications](#)
3. [Safety Information](#)
4. [Warranty](#)
5. [Pre-Operation Checklist](#)
6. [Standard Operation Procedures](#)
7. [Points to Remember](#)
8. [Maintenance Schedule](#)
9. [Maintenance](#)
10. [Safety and Instructional Decals](#)
11. [Operating Positions](#)
12. [Assembly, Generic Transmission Cover](#)
13. [Assembly, Body](#)
14. [Assembly, Foot Pedal](#)
15. [Assembly, Drive Unit](#)
16. [Assembly, Engine Mount, GX200](#)
17. [Assembly, Hydraulic Drive](#)
18. [Assembly, Transmission Unit](#)
19. [Assembly, Chain Tensioner Arm - LH](#)
20. [Assembly, Chain Tensioner Arm - RH](#)
21. [Assembly, Flex Tube Drive Roller](#)
22. [Assembly, Flex Chain Drive Roller](#)
23. [Assembly, Steering Overlapping Heads](#)
24. [Assembly, Front Smoothing Head](#)
25. [Assembly, Rear Smoothing Head](#)
26. [Connecting Rods](#)
27. [Assembly, Joystick](#)
28. [Assembly, Trailer](#)
29. [Assembly, Trailer Hub](#)
30. [Assembly, Seat & Frame](#)
31. [Assembly, Seat](#)
32. [Harness Loom](#)
33. [Troubleshooting : Roller](#)
34. [Available Spare Parts](#)

Separate engine Owner's Manual can be downloaded from www.truturf.com or from Honda website: [Honda GX200](#)

Machine Information Record

Congratulations on your investment in the RB48 Golf Greens Roller and your move to smoother, faster, more consistent putting greens.

The following operation and maintenance manual has been prepared for use with the RB48 Golf Greens Roller.

It is intended as a guide and supplemental updates to the manual may take place at a future date, without prior notice. For the latest information visit www.truturf.com

This machine is engineered to be simple to operate and easy to maintain.

If you have any questions or concerns that this manual does not address, please feel free to contact your distributor or email technicalsupport@truturf.com

Distributor Information

Name _____

Address _____

Phone _____

Fax _____

Email _____

Machine Information - RB48 Golf Green Roller

Serial No. _____

Engine No. _____

Transmission No. _____

Purchase Date No. _____



Each page contains a *Table of Contents* hyperlink, see lower centre of page.



Specifications

Engine Type Horsepower Lighting Oil Capacity	Honda - Gasoline 6.5 hp, (4.85kw) Yes 0.63qts (0.6L)
Transmission Manufacturer Type	Eaton Hydrostatic 11
Oil Capacity	6qts (6.84L) + Filter
Cooling	8 blade hydro transmission cooling fan
Drivetrain	1/2" duplex chain, self adjusting ISO 08B2
Drive Roller	Rubber coated, non-stick
Direction Control	Foot pedals
Speed Control	Foot pedals
Operating Speed	0-9 mph (0-15kph)
Steering	Joystick - Light load, directly connected to smoothing heads
Vibration	Reduced through engine isolation mounts

Seat	Premium UV protected, with adjustable arm rests
Trailer	Integrated, heavy duty. Quick & easy transition from transport to rolling position
Ground Pressure (Footprint)	3.7 psi (25.5 kPa)
Rolling Width (Swath)	48" (1220mm)
Weight - Operating	638lbs. (290kg)
Tires	18 x 6.50 x 8
Start / Stop	Switch & recoil
Brake - Park	Handbrake , Disc style
OPS Safety Switch	Seat activated
Optional Equipment	Lights & Drawbar coupling
Warranty	2 years - Limited manufacturers warranty

Safety Information

Safety is of the utmost importance when operating turf equipment.

To ensure safe operation of the RB48 Golf Greens Roller, please follow the following safety guidelines.

- Always make a pre-operation inspection before you start rolling. If this procedure is not carried out, damage to property or personnel may occur.
- Keep children, pets and inexperienced personnel away from the machine. This machine should only be operated by **trained** and **skilled personnel** - check with your supervisor if you are unsure.
- Know how to stop the machine when in motion. Read and understand manufacturers manual, as supplied.
- Never permit **inexperienced operators** to use the machine. This machine requires certain knowledge and expertise to operate it; you must be a trained person to use this machine. Unskilled persons can harm themselves and others if they operate this machine.
- When transporting the roller or carrying out maintenance, make sure the trailer lockdown mechanism is secured by the locking pin to prevent premature release of the catch.
- If the trailer catch is not correctly engaged while towing and releases accidentally, the front of the roller can drop and dig into the ground, causing the machine to move dangerously in any direction causing bodily injury and result in damage to the drive roller and other components.
- When the roller is running, always keep hands and loose clothing away from rotating shafts, chains, belts and sprockets in the transmission area.
- This machine should not be used on slopes greater than 10 degrees.
- It is recommended to wear appropriate person protection equipment, (PPE), as per local laws. These may include hearing protection, eyes and appropriate closed shoes and clothing PPE. Environmental conditions should also be taken into consideration.



Safety Information

- If hair, clothing, or loose objects become entangled on a rotating shaft, serious bodily injury could occur. Always stop engine before opening safety cover.
- Never ride on the machine when machine is being towed.

Operator: remember it is your responsibility to be aware of your surroundings.

To avoid accidents, think safe and operate safe.



IMPORTANT EU MACHINERY DIRECTIVE INFORMATION

SAFETY WARNINGS

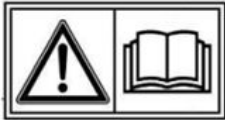

Read Operator's Manual.

Only personnel that have read and fully understood the Operator's Manual should operate this equipment.



Keep Bystanders Away.

The operator should ensure that bystanders are not in the immediate vicinity of the machine when it is in use.



Machine Rollover.

Do not use this machine on slopes greater than 10 degrees.



Hearing Protection.

Hearing protection to be worn whilst operating this machine.

IMPORTANT EU MACHINERY DIRECTIVE INFORMATION

SAFETY WARNINGS

SOUND AND VIBRATION LEVELS

The sound and whole body/hand/arm vibration levels are shown below. Please take note of the levels and determine appropriate operator actions, (wearing hearing protection and/or limiting the time of use when operating the machinery).

Sound Levels	
Measured Sound Pressure – LpA dB(A)	Guaranteed Sound Pressure – LwA dB(A)
91	101

Vibration Levels			
	Measured value (m/s^2)	Time to reach Exposure Action Value	Time to reach Exposure Limit Value
Hand/Arm	2.1	n/a	n/a
Whole Body	1.1	1hr50min	9hr46min

Readings taken at full power

Warranty

Conditions and Products Covered

Tru-Turf warrant your Tru-Turf Roller to be free from defects in materials or workmanship for two years or 1550 operational hours*, whichever occurs first.

This warranty is applicable to all products. Where a warrantable condition exists, we will repair the product at no cost to you including diagnostics, labor, and parts. This warranty begins on the date the product is delivered to the original retail purchaser.

- Product to be equipped with an operating hour meter fitted.

Claiming Warranty Service

You are responsible for notifying the Products Distributor or Authorized Products Dealer from whom you purchased the product as soon as you believe a warrantable condition exists. If you need help locating a products distributor or authorized dealer, or if you have questions regarding your warranty rights or responsibilities, you may contact us at:

Tru-Turf Service Department

Tru-Turf Pty Ltd

16/6 Energy Circuit, Robina

Queensland 4221,

Australia

E-mail: technicalsupport@truturf.com

Owner Responsibilities

As the Product Owner, you are responsible for required maintenance and adjustments stated in your Operator's Manual. Failure to perform required maintenance and adjustments can be grounds for disallowing a warranty claim.



Warranty

Items and Conditions Not Covered

Not all product failures or malfunctions that occur during the warranty period are defects in materials or workmanship. This warranty does not cover the following:

- Product failures which result from the use of non-Tru-Turf replacement parts, or from installation and use of add-on, or modified non-Tru-Turf branded accessories and products.
- Product failures which result from failure to perform recommended maintenance and/or adjustments. Failure to properly maintain your Tru-Turf roller per the Recommended Maintenance listed in the Operator's Manual can result in claims for warranty being denied.
- Product failures which result from operating the Product in an abusive, negligent, or reckless manner.
- Parts subject to consumption through use unless found to be defective. Examples of parts which are consumed, or used up, during normal Product operation include, but are not limited to, brakes pads and linings, slicers, spiker tines, tires, filters, belts, springs, sprockets, chains, bearings and pulleys.
- Failures caused by outside influence. Items considered to be outside influence include, but are not limited to, weather, storage practices, contamination, use of unapproved lubricants or additives, etc.
- Normal noise, vibration, wear and tear, and deterioration.
- Normal "wear and tear" includes, but is not limited to, damage to seats due to wear or abrasion, worn painted surfaces or scratched decals.



Warranty

- Specific component parts supplied to Tru-Turf by OEM suppliers are covered by that supplier's Warranty. These parts and components include but are not limited to, Eaton Transmissions, Honda Engines, Sevcon Controllers, Foot Pedal & Trailer Arm Struts, Curtis Controllers & Electronic Foot Pedals, Toggle Switch, Rexnord Gearboxes & Electric Motors, Seats, Drive Rollers, Hour Meter, Rod Ends, Lights, Hood, Transmission Cover, Fan, Rubber Coupling.

Parts

Parts scheduled for replacement as required maintenance are warranted for the period up to the scheduled replacement time for that part. Parts replaced under this warranty are covered for the duration of the original product warranty and the removed parts become the property of Tru-Turf. Tru-Turf will make the final decision whether to repair any existing part or assembly or replace it. Tru-Turf may use remanufactured parts for warranty repairs.

Note Regarding Deep Cycle Battery Warranty:

- Deep cycle batteries have a specified total number of kilowatt-hours they can deliver during their lifetime. Operating, recharging, and maintenance techniques can extend or reduce total battery life. As the batteries in this product are consumed, the amount of useful work between charging intervals will slowly decrease until the battery is completely worn out.
- Replacement of worn-out batteries, due to normal consumption, is the responsibility of the product owner. Battery replacement may be required during the normal product warranty period at owner's expense.

Maintenance is at Owner's Expense

Maintenance of your Tru-Turf roller is to be conducted as per the owner's manual for your Tru-Turf product at the owner's expense.



Warranty

General Conditions

Repair by an Authorized Tru-Turf Distributor or Dealer is your sole remedy under this warranty.

Tru-Turf is not liable for indirect, incidental or consequential damages in connection with the use of the Tru-Turf Products covered by this warranty, including any cost or expense of providing substitute equipment or service during reasonable periods of malfunction or non-use pending completion of repairs under this warranty. Except for the Emissions warranty referenced below, if applicable, there is no other express warranty.

All implied warranties of merchantability and fitness for use are limited to the duration of this express warranty. Some states/ countries do not allow exclusions of incidental or consequential damages, or limitations on how long an implied warranty lasts, so the above exclusions and limitations may not apply to you.

This warranty gives you specific legal rights, and you may also have other rights which vary from state to state and country to country.



Pre-Operation Checklist

- Ensure steering joystick has no looseness.
- Check that foot pedal depresses under normal foot pressure.
- Ensure that the draw bar locking catch mechanism is securely locked to the main draw bar and the safety pin is fitted when trailing the roller.
- Check and tighten grub screws fitted to the end bearing lock rings on the rubber coated drive roller and the spiker shaft bearings (if fitted) & pivot bearings on each smoothing head.
- Lightly grease bearings fitted to drive roller, spiker shaft (if fitted) and Smoothing Head pivot bearings. Replace plastic caps if missing.
- Oil rod ends, sparingly.
- Check tire pressure for proper operating pressure (18-24psi). Do not over inflate.



Standard Operation Procedures

1. Inspect and check that the roller is serviceable prior to departing from the workshop.
2. Use a suitable towing vehicle to move the roller from green to green.
3. Maximum recommended towing speed would be equal to a motorized golf buggy, i.e., approximately 10-12mph/ 16-19kph. Towing at excess speed or across rough terrain may cause damage to the machine and trailer.
4. When approaching the green do not tow the roller onto the green to set up, put the roller on the fringe of the green. Put trailer in the up position, switch on the roller and drive it onto the green.
5. Greens can be rolled in any direction; take care to ensure there are no crease lines produced on the surface.
7. It is recommended that you place the smoothing head rollers on the high side of the green when rolling. This increases the weight onto the rubber drive roller and creates better traction, it also reduces slipping or spinning of the drive roller on the green, depending on the operator's ability.
8. Whilst becoming familiar with the roller, set the throttle at about 1/2 - 3/4 speed. Press the left or right foot pedal down gently but not suddenly. Be smooth with your action, hold in this position until nearing the edge of the green, then take your foot gently off the pedal, the roller will come to a stop. Rest your other foot on the opposite pedal and gently apply the pressure to the pedal. It then starts to move the roller in the opposite direction. Once again be gentle with the pedal, but not sudden. By using the left and right pedal in this manner, will ensure there is no damage to the green and less wear and tear on the equipment and operator.



Standard Operation Procedures

8. The correct procedure for rolling the green is:
 - a) Select the correct direction to roll the green, remember this roller can roll the greens in all directions.
 - b) Start on one side of the green and work your way across the green in a zigzag fashion, slightly overlapping each lap you roll: this makes sure you don't miss any part of the green and all of the green is rolled. Avoid coming back across the green to roll missed areas if possible. You should be able to complete the rolling of 18 greens in the same amount of time, or quicker, than by mowing using a triplex mower.
9. When rolling of the green is completed, move the roller onto the fringe, switch off the ignition, lock the trailer into the towing position, connect it to the towing vehicle then move off to the next green to be rolled.
10. When using the pin hitch style drawbar, the following 3 points must be adhered to.
 - a) Ensure that the hole size in the tow hitch fitted to the towing vehicle is at least 3/8" (10mm) larger in

diameter than the pin size fitted on the roller draw bar hitch.

- b) When towing forwards or reversing, be sure that the roller is not put into a jack-knifed position, if it is, then damage to the pin hitch will occur.
- c) Do not cross excessively steep hills or dips where the tow hitch pin may gouge the turf and damage the drive roller.

Do not put the trailer down into the towing position on the green; damage may occur to the green from the roller tires and body.

Towing

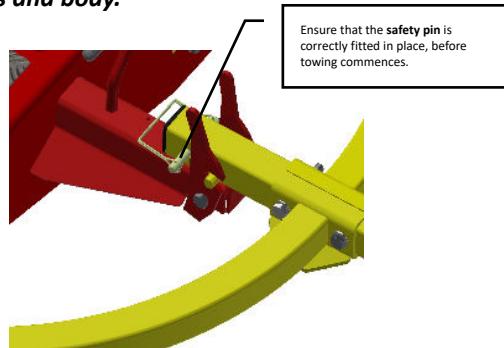

Standard Operation Procedures

11. This machine is equipped with a seat safety switch. This operates in the same way as that on the ride-on mowers, where if the operator attempts to leave the seat whilst the engine is running and has not fully engaged the parking brake, the engine will stop.
12. Starting the engine. The engine will not start unless the park brake lever is in the fully engaged or in the **on** position. Refer to the Honda user manual for correct engine starting and running procedures.
13. Ensure that the fuel cock is switched to the **off** position whilst transporting the roller between greens, otherwise flooding of the engine with fuel may occur. This causes difficulties in the starting of the engine.
14. Keep the roller on the greens surface. It is not necessary to roll onto the collars or fringes.
15. The operator needs to become familiar with the timing required to stop and the distance required to do so at the speed being travelled, remembering that the roller is quite heavy.
16. There is a park brake fitted to the roller. This is to be used only in an emergency or when parking or leaving the machine, especially on an incline. The park brake should not be used in the normal operation of the roller.

Park Brake

The park brake lever operates on an over-centre principal.

To engage the park brake, pull the park brake lever fully up and back.

The park brake lever will remain in this **on** position.

To disengage the park brake, push the park brake lever fully forward and down.

The park brake lever will remain in this **off** position.

Always operate the roller with the park brake off!

Caution: Do not operate the roller with the park brake engaged as this will damage park brake components.

When stopping and before getting off the machine, always apply the Park Brake.



Transport lifting

WARNING: The lift points shown in the diagram, **must only** be used to lift the machine to carry out transport lifting. It is not permitted to carry out maintenance whilst the roller is hanging from the slings.

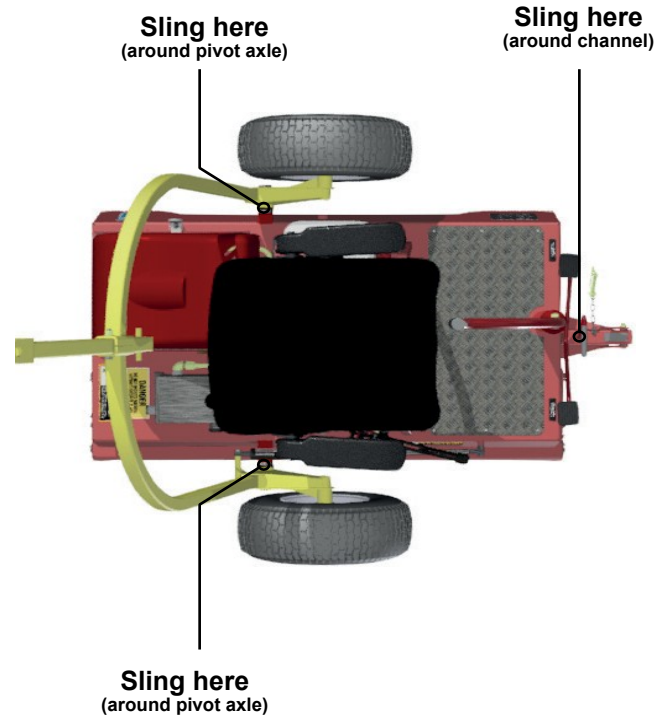

Points to Remember

- Make sure the roller is serviceable before rolling.
- Start rolling from the fringe of the green.
- Pick a point on the other side of the green to roll to.
- Do not look at the green close to the roller, it makes it difficult to steer the roller straight. Look well ahead.
- Use 1/2 throttle until you are proficient at operating the roller.
- Once you choose your rolling line hold the joystick steady, correcting direction gently as required.
- Move the steering joystick a little at a time to change direction; excessive movement of the joystick makes it difficult to maintain a straight line.
- Roll in straight lines.
- Do not leave the engine running with the roller parked on the green; the engine vibration will cause roller depression marks on the green.
- Move off the green when rolling is complete before putting the trailer in the down position.
- When rolling steep greens and the engine stops, check engine oil level. The engine is fitted with a safety switch; when the engine oil level is low the engine will stop.
- When stopping and before getting off the machine always apply the **Park Brake**.
- **Remember turn off the fuel cock whilst towing the roller.**



Maintenance Schedule

Description	Pre-Delivery	Pre-Operating	Monthly	12 Monthly
Check engine oil	√	√		
Check transmission oil level	√	√		
Beware of contaminants entering the transmission	√	√		
Lubricate drive chain	√	√		
Check tires max 18 psi	√	√		
Check fuel level	√	√		
Check smoothing roller bearings	√	√	√	
Check drive roller bearings	√	√	√	
Check for loose nuts and bolts	√	√		
Renew engine oil	As per manufacturers handbook			
Renew transmission oil	Every 500hrs or 12 monthly			
Renew transmission oil filter		*		√
Renew smoothing roller bearings		*		√
Renew drive roller bearings		*		√
Renew chain tensioner wear pads		*		as required
Renew drive chain		*		√
Replace foot pedal struts	*			as required
Replace trailer strut		*		as required

Note. Areas indicated with a * need to be changed when defective or as required. This may be before the recommended replacement schedule.

Please replace all parts, as necessary.



Maintenance

Safety

You must always employ safe working practices when performing any assembly or service tasks on the machine.

For carrying out service, the trailer must be secured in the towing position. The roller can then be raised by either employing car ramps or a suitable motor vehicle hoist. The trailer wheels must be secured to prevent movement.

Important: If maintenance is carried out correctly, there is no need to crawl under the roller machine at any time. All maintenance can be done by reaching from the outside.

Storing

It is important to store this roller in the towing position. This ensures the trailer gas strut is in the closed position, protecting the shaft from the elements which, if damaged, would accelerate seal wear.

Adjusting the Pedals

If the direction foot pedals become unbalanced for any reason it can be adjusted as follows. Open the transmission cover. It will be necessary to have the engine running and the roller in the transport position, suspended horizontal while performing this process. Take care to keep all limbs and clothing well away from the rotating shaft and coupling. Using the correct spanner release the lock nut on the gas strut. Rotate each strut to return the pedals to a central position while at the same time ensuring that the transmission is not engaging when in the central neutral position. Reset the locknut after performing this procedure to both struts.



Maintenance

Service of the drive chain system

- Replacement - use only the chain and sprockets recommended as per the correct spare parts number. Wrong pitch drive chain fitted will cause excessive sprocket wear and possible drive failure.
- Tensioning the drive chain - No adjustment is required; the chain tension is automatically adjusted

Lubrication

Lubricate drive chain with a chain lube such as Molykote, Innox or ChunkaRocol ITW. Spray on the inside of the chain so that the lubricant is forced into each roller and around each pin prior to rolling of the Greens. Do not over lubricate.

Service of smoothing roller bearings

- Whilst the Roller is suspended by the Trailer, check operational smoothness of the bearings fitted to each smoothing roller by rotating the rollers by hand. If bearing tightness, roughness or excessive looseness is detected, replace the faulty bearings.

- If bearings are faulty:

- a) Remove the complete smoothing head unit assembly from the machine, undo the four swivel mount bolts on the upper body and disconnect the steering rod, wheel the roller away until the total head assembly is exposed to work on.
- b) Remove roller shaft bolts from end plates, remove rollers from the heads.
- c) Fit new bearings, replace rollers into the heads, lubricate shaft bolts with an anti-seize compound before installing them. Tighten securely and ensure rollers rotate freely when fully tightened.
- d) If the connecting rods are removed or lengths altered ensure they are correctly adjusted so that the two heads are parallel to each other when in the straight-ahead position. Adjust if necessary.



Maintenance

Changing engine oil

Change oil and service as per the manufacturers servicing schedule. Click link below and find engine serial number for current owner's manual from the web page list.

[Honda GX200](#)

Changing transmission oil

Ongoing Maintenance, Lubricant and Replacement Schedule (See [Maintenance Schedule](#) chart).

Transmission pump, (Eaton 11)

- Initially, change the oil at 50 hours running time, then; change oil every 500 hours or annually, whichever occurs first.
- Change hydraulic oil filter every 500 hours or annually, whichever occurs first.
- Only use the manufacturer's recommended replacement oil filter. When fitting the filter, follow the instructions supplied with the filter. This will ensure that the filter remains tight and that no leaks occur.
- Check all hard-line oil pipes for rubbing, excessive vibration, leaks and tightness on a regular basis.
- Check transmission oil level on oil tank sight glass. Oil level should remain at a minimum of 25mm (1") and at a maximum of 40mm (1.5") from the top of the tank.
- Oil Capacity including filter is 6 litres or 5.3 U.S. quarts. For the ultimate performance we use and recommend the Penrite synthetic 5 SAE 5W-60 transmission oil (Part No. R5226) or synthetic oil equivalent.



Maintenance

Testing Park Brake

Stop the machine safely on level ground and engage the park brake.

Switch off and dismount from the machine.

Try to push the machine manually.

The park brake must prevent machine from moving. If the machine moves, the parking brake requires adjusting.

Adjusting Park Brake

To adjust the park brake, rotate the knob at the end of the park brake lever in a clockwise direction, when looking down at the lever.

Pressurized liquid/gas

- This roller makes use of pressurised gas cylinders and hydraulic lines.
- **Do not** try to open or re-gas pressurized cylinder. Replace with new.
- Only hydraulic qualified personnel to service the hydraulic lines/ components.



Safety and Instructional Decals

Safety decals and instructions are easily visible to the operator and are located near any area of potential danger. Replace any decal that is damaged or missing.



R9483 - Machine ID Plate.
(Note: This is not a spare part
and will come attached from
manufacturer).

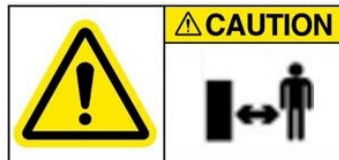

R9870 KEEP BYSTANDERS AWAY

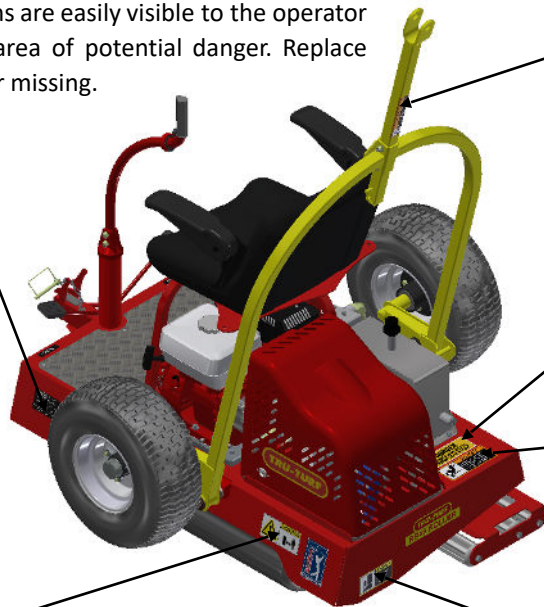

E8858 DRAWBAR LIFTING



R6041 COVER IN PLACE



R9086 CHAIN/BELT PINCH POINT



R9087 PINCH POINT

Safety and Instructional Decals

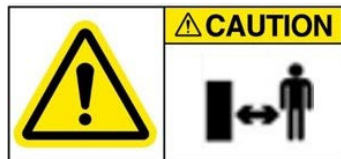

R9870 KEEP BYSTANDERS AWAY

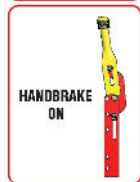

E7068 HANDBRAKE
INSTRUCTIONS

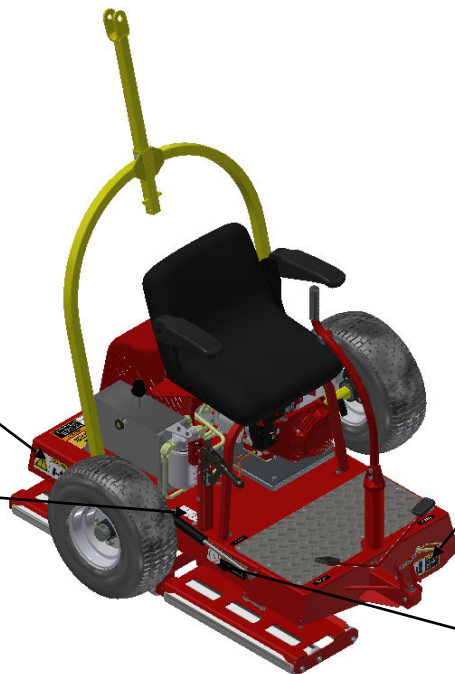

R9087 PINCH POINT



R8452 STRUT REQUIRED

Operating Positions



Towing position

Rolling position



Assembly, Generic Transmission Cover

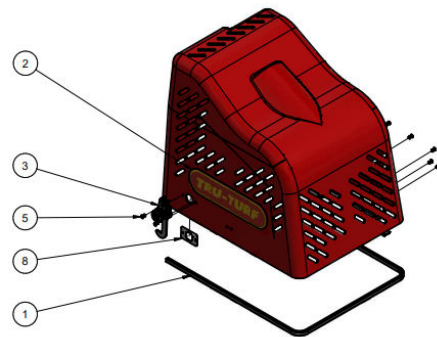
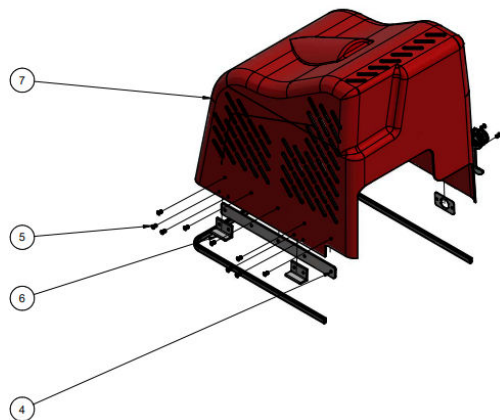

PARTS LIST			
ITEM	QTY	PART NUMBER	DESCRIPTION
1	1	R5241	PINCHWELD EDGE, PROTECTOR TRANS COVER
2	1	R6057	DECAL, TRU-TURF LOGO
3	1	R8343	LATCH, PULL-AND-LOCK HOOK (1-250) - DIRAK
4	1	R9495	STIFFENER, GENERIC TRANS COVER
5	11	R9594	5/32" X 13mm RIVET, ALUMINIUM
6	2	RS2427	FOOT, COVER, SHORT
7	1	RS2452	GENERIC TRANSMISSION COVER
8	1	T39688	PLATE, MOUNT, LATCH, FIBREGLASS COVER

PART NUMBER: RS2425
 REVISION: F
 DATE: 06/01/2023
 BY: SP

PART NUMBER: RS2425
 REVISION: F

Assembly, Body

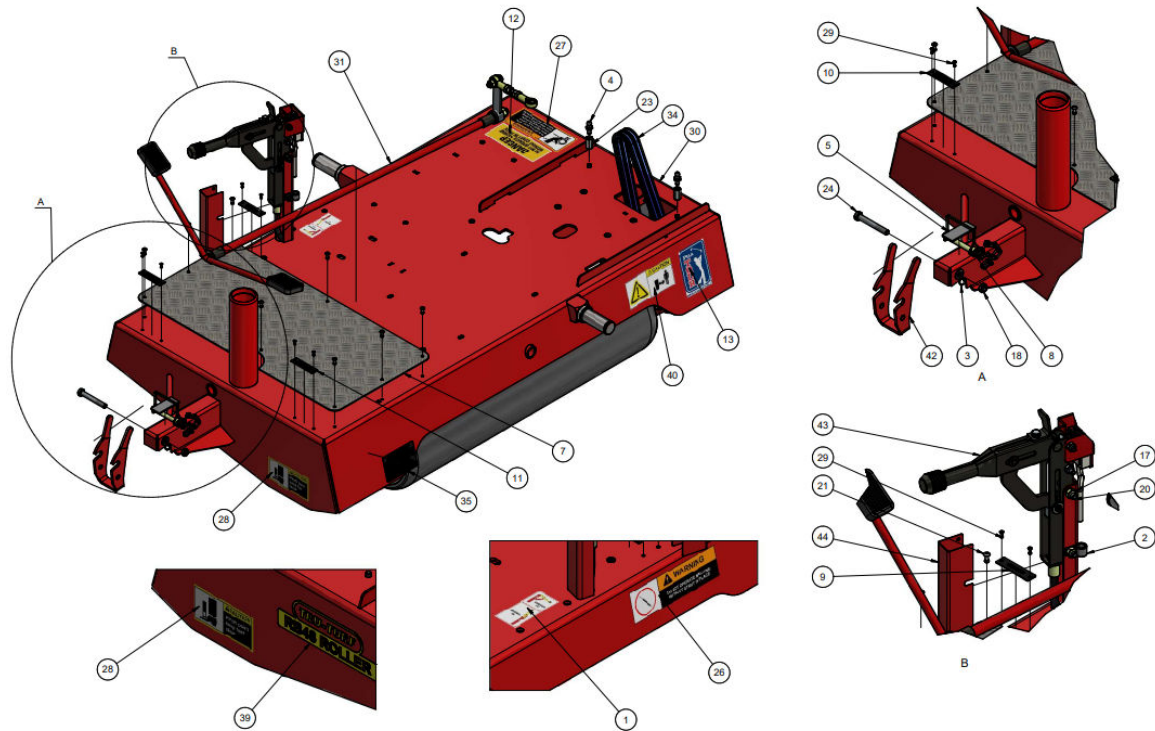

PART NUMBER: R9455
REVISION: F



Assembly, Body

PARTS LIST				PARTS LIST			
ITEM	QTY	PART NUMBER	DESCRIPTION	ITEM	QTY	PART NUMBER	DESCRIPTION
23	2	R8171	M8 X 25 SOCKET NUT, ZP	1	1	E7068	DECAL, HAND BRAKE OPERATION INSTRUCTION
24	1	R8190	3/8" UNF X 2-3/4" BOLT, ZP	2	2	E7076	CLIP, P, 10 mm
25	2	R8256	M8 NYLOC NUT, ZP	3	1	R5049	SPRING, EXTENSION, ZP - Ø1/2"x18g.x5" LG
26	1	R8452	DECAL, WARNING - DO NOT OPERATE WITHOUT STRUT	4	2	R5108	BALL STUD 10mm SMALL FLANGE ZP
27	1	R9086	DECAL, PINCH POINT - FINGERS	5	1	R5159	REST, RUBBER, TRAILER - 3 mm THK.
28	2	R9087	DECAL, PINCH POINT - FEET	6	2	R6013	BUFFER STOP, UNDER BODY
29	6	R9210	4-5 RIVET, ALUMINIUM, BLK	7	1	R6015	FOOT PAD
30	1	R9451	WELDMENT, DECK	8	1	R6017	ASSEMBLY, DRAWBAR SAFETY PIN & CHAIN
31	1	R9453	ASSEMBLY, FOOT PEDAL	9	1	R6023	PLATE, LABEL, PARK BRAKE
32	1	R9456	ASSEMBLY, DRIVE ROLLER, COMPACT	10	1	R6024	PLATE, INSTRUCTION, MOVE RIGHT
33	1	R9476	MUD FLAP MODIFICATION	11	1	R6025	PLATE, INSTRUCTION, MOVE LEFT
34	1	R9477	DRIVE CHAIN, DUPLEX (08B-2)	12	2	R6041	DECAL, DANGER - COVER IN PLACE
35	1	R9483	DECAL, SERIAL NUMBER, RB48	13	1	R6059	DECAL, PGA TOUR
36	1	R9487	CALIPER MOUNTING BRACKET	14	2	R8034	M8 SPRING WASHER, ZP
37	1	R9496	BRAKE CALLIPER, LH, (#400281)	15	2	R8037	M8 X 12 SET SCREW, ZP
38	1	R9497	ASSEMBLY, CABLE, DISC BRAKE	16	2	R8053	1/4" UNF NYLOC NUT, ZP
39	1	R9510	DECAL, MODEL ID	17	2	R8054	5/16" UNF NYLOC NUT, ZP
40	2	R9870	DECAL, KEEP BYSTANDERS AWAY	18	1	R8056	3/8" UNF NYLOC NUT, (TYPE T), ZP
41	1	RS48-21B	STRAP MUDFLAP SCREW ON	19	2	R8081	10-24 X 16 TEK SCREW, ZP
42	1	RS2117	CATCH, WIDE, FOLDED, TRAILER DRAWBAR	20	2	R8095	5/16" UNF X 2" BOLT, ZP
43	1	RS2123	ASSEMBLY, HANDBRAKE LEVER WITH SWITCH	21	8	R8134	6-6 RIVET, ALUMINIUM
44	1	RS2126	COVER, SAFETY, S/S, HANDBRAKE LEVER	22	2	R8137	1/4" UNF X 3/4" SET SCREW, ZP

PART NUMBER: R9455
 REVISION: F
 DATE: 08/02/2023
 BY: SP



Assembly, Body

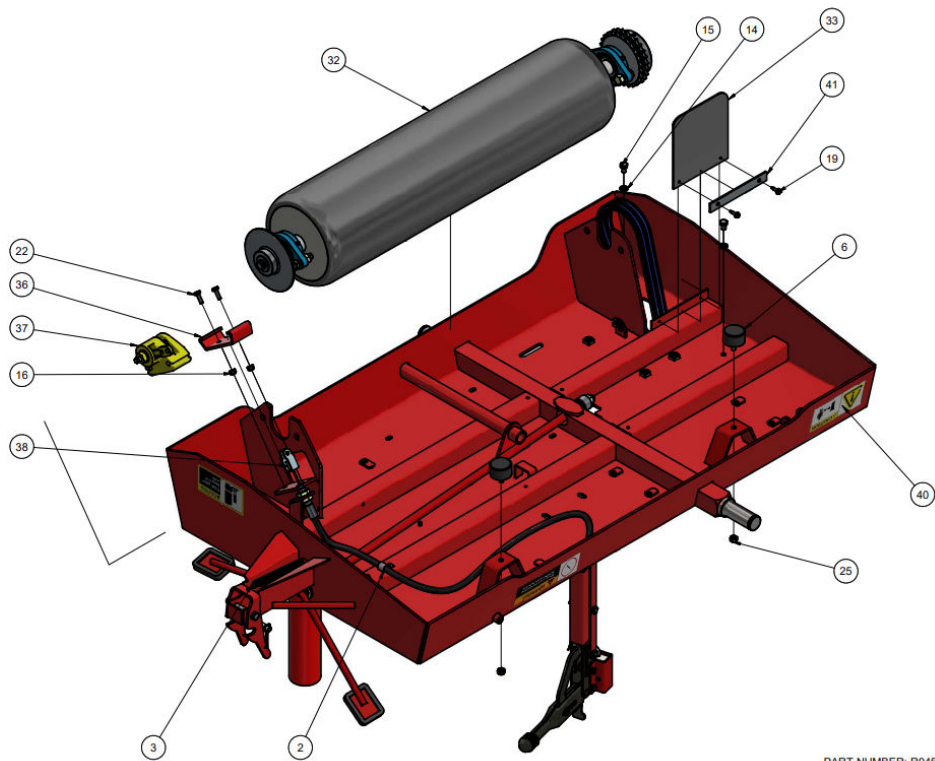

PART NUMBER: R9455
REVISION: F



Assembly, Foot Pedal

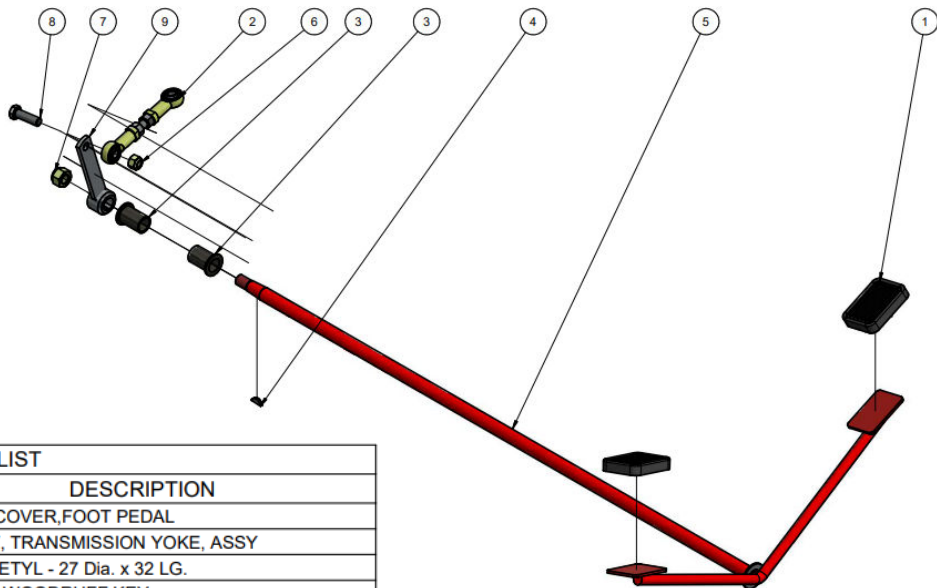

PARTS LIST			
ITEM	QTY	PART NUMBER	DESCRIPTION
1	2	R5012	RUBBER COVER, FOOT PEDAL
2	1	R5046	ROD UNIT, TRANSMISSION YOKE, ASSY
3	2	R5075	BUSH, ACETYL - 27 Dia. x 32 LG.
4	1	R5156	1/8" X 5/8" WOODRUFF KEY
5	1	R8001	WELDMENT, FOOT PEDAL
6	1	R8055	3/8" UNF NYLOC NUT, ZP
7	1	R8060	1/2" UNC NYLOC NUT, ZP
8	1	R8069	3/8" UNF X 1-1/4" SET SCREW, ZP
9	1	R9462	WELDMENT, FOOT PEDAL ARM

PART NUMBER: R9453

REVISION: A

DATE: 11/08/2021

BY: SP

PART NUMBER: R9453

REVISION: A

Assembly, Drive Unit

PARTS LIST			
ITEM	QTY	PART NUMBER	DESCRIPTION
1	1	R9427	ASSEMBLY, ENGINE MOUNT, GX200
2	1	RS2155	DRAIN HOSE - HONDA ENGINE GX200
3	1	RS2418	ASSEMBLY, HYDRAULIC DRIVE
4	1	RS2419	ASSEMBLY, DRIVE COUPLING

PART NUMBER: RS2410

REVISION: C

DATE: 02/10/2020

BY: SP

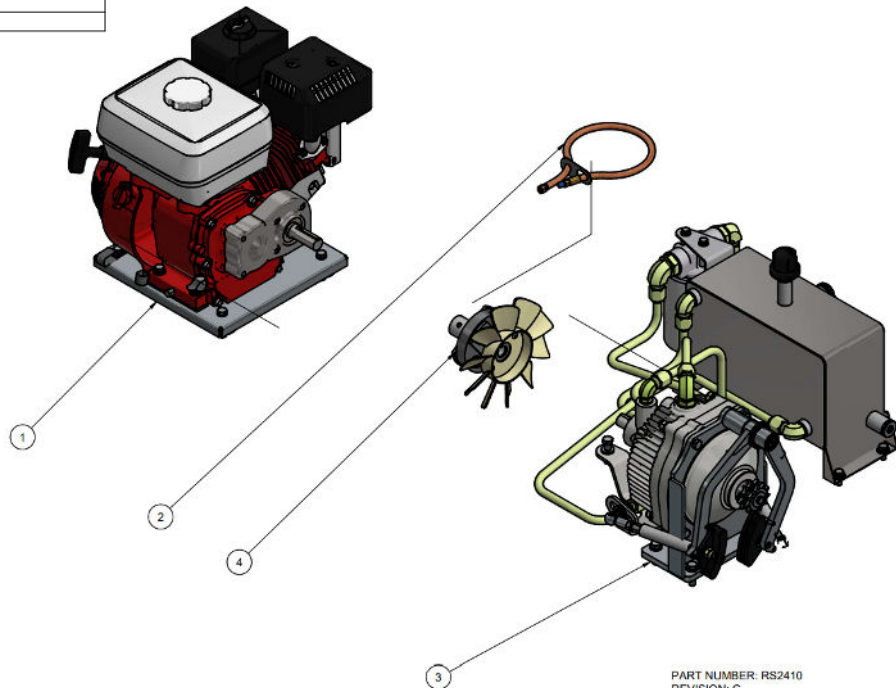

PART NUMBER: RS2410
REVISION: C

Assembly, Engine Mount, GX200

PARTS LIST			
ITEM	QTY	PART NUMBER	DESCRIPTION
1	4	R9142	ISOLATION MOUNT
2	1	R5149	PLATE, ENGINE MOUNT, WELDED, ASSY
3	4	R8043	M8 NUT, ZP
4	4	R8048	3/8" X 3/4" FLAT WASHER, ZP
5	12	R8051	5/16" SPRING WASHER, ZP
6	4	R8065	5/16" UNF X 1-1/2" BOLT, ZP
7	4	R8083	M8 X 16 SET SCREW, ZP
8	4	R8200	1/4" X 9/16" X 1/16" FLAT WASHER, ZP
9	1	R9001	ENGINE, HONDA, GX200, 2:1 REDUCTION
10	1	R9155	J-CLIP, VINYL, 5/16" X 9/32"
11	1	R9156	DOUBLE TUBE CLAMP, 5/16" X 13/32" X 11/16"
12	4	T39072	SHIM, ADJUSTING, ENGINE MOUNT

PART NUMBER: R9427

REVISION: A

DATE: 28/12/2020

BY: SP

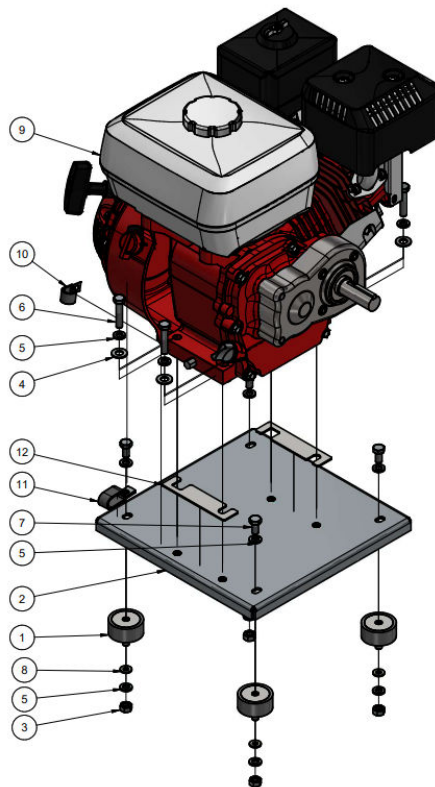

PART NUMBER: R9427
REVISION: A

Assembly, Hydraulic Drive

PARTS LIST			
ITEM	QTY	PART NUMBER	DESCRIPTION
1	1	R5144	BREATHER, OIL TANK
2	1	R5147	CARTRIDGE, FILTER, TRANSMISSION OIL TANK
3	1	R5227	ELBOW, 90 DEG, 9/16-18 JIC - 7/8-14 UNO (M-M)
4	2	R5229	ELBOW, 90 DEG, 3/4-16 JIC - 3/4-14 BSPP (M-M)
5	1	R5230	STRAIGHT, 3/4 JIC - 7/8 UNO (M-M)
6	2	R5232	ELBOW, 90 DEG, 1/2-14 BSPT - 3/4-16 JIC (M-M)
7	2	R5233	ELBOW, 90 DEG, 3/4-16 JIC - 9/16-18 UNO-ADJ (M-M)
8	1	R5234	ELBOW, 90 DEG, 1/2 JIC - SWIVEL - 1/2 JIC - (F-M)
9	1	R8013	HOUSING, FILTER, TRANSMISSION OIL TANK
10	4	R8046	5/16" X 3/4" FLAT WASHER, ZP
11	2	R8050	1/4" SPRING WASHER, ZP
12	4	R8051	5/16" SPRING WASHER, ZP
13	2	R8118	BOLT, HEX, ZP - 1/4" UNC x 3/4" LG
14	4	R8177	5/16" UNF X 3/4" SET SCREW, ZP
15	2	R8200	1/4" X 9/16" X 1/16" FLAT WASHER, ZP
16	1	R8669	TUBE, TANK OUT - PUMP IN
17	1	R8870	TUBE, PUMP OUT - FILTER IN
18	1	R8871	TUBE, FILTER OUT - DRIVE IN
19	1	R8872	TUBE, DRIVE OUT - TANK IN
20	1	R8930	OIL LEVEL SITE GLASS
21	1	RS2061	ASSEMBLY, TRANSMISSION UNIT
22	1	RS2417	WELDMENT, HYD TANK

PART NUMBER: RS2418
 REVISION: C
 DATE: 28/12/2020
 BY: SP

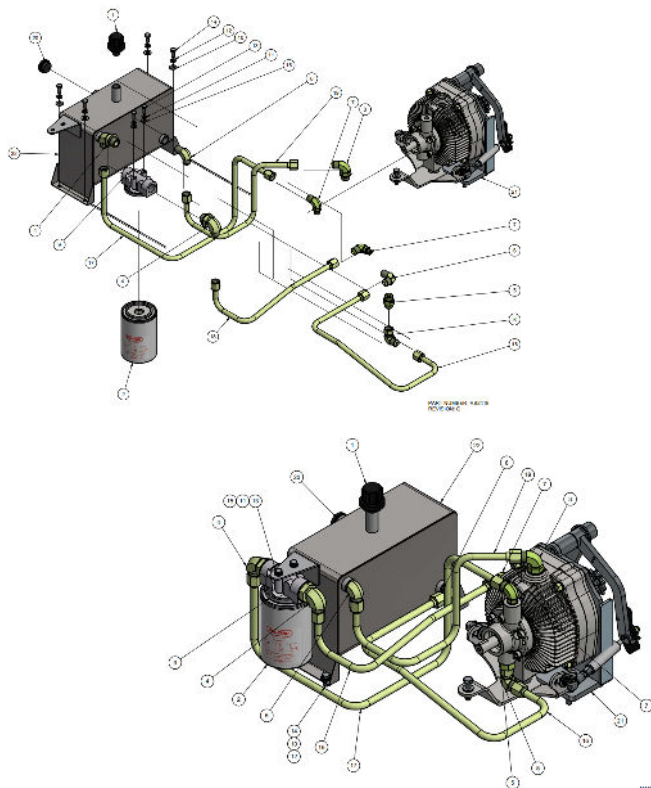

Assembly, Transmission Unit

PARTS LIST			
ITEM	QTY	PART NUMBER	DESCRIPTION
1	1	R5089	3/16" X 3/4" WOODRUFF KEY
2	1	R5094	SPRING, TENSIONED, CHAIN ARM
3	1	R5131	BRACKET, TRANSMISSION, WELDED, EATON 11, ASSY
4	1	R5133	EATON 11 HYDROSTATIC TRANSMISSION - 1100-078
5	1	R5136	SPROCKET, 11TOOTH, TRANS. CHAIN 08B-2
6	1	R5156	1/8" X 5/8" WOODRUFF KEY
7	1	R5171	WELDMENT, TRANSMISSION YOKE
8	2	R5173	ASSEMBLY, STRUT, TRANSMISSION
9	1	R5251	ASSEMBLY, CHAIN TENSIONER ARM, LH
10	1	R5251_1	ASSEMBLY, CHAIN TENSIONER ARM, RH
11	2	R8045	1/4" X 1" FLAT WASHER, ZP
12	4	R8047	5/16" X 1" FLAT WASHER, ZP
13	7	R8048	3/8" X 3/4" FLAT WASHER, ZP
14	1	R8050	1/4" SPRING WASHER, ZP
15	4	R8052	3/8" SPRING WASHER, ZP
16	5	R8055	3/8" UNF NYLOC NUT, ZP
17	1	R8059	1/4" UNC X 1" SET SCREW, ZP
18	1	R8060	1/2" UNC NYLOC NUT, ZP
19	4	R8069	3/8" UNF X 1-1/4" SET SCREW, ZP
20	1	R8070	3/8" UNF X 1-1/2" SET SCREW, ZP
21	4	R8073	3/8" UNF X 3" BOLT, ZP
22	1	R8118	1/4" UNC X 3/4" SET SCREW, ZP
23	2	R8210	Ø13 BALL STUD, M8X22 (STABILUS)
24	4	R8218	12.7 X 25.4 X 1.6mm FLAT WASHER, ACETAL
25	2	R8256	M8 NYLOC NUT, ZP
26	1	R9085	KEY, OUTPUT SHAFT, EATON 11
27	2	T39478	SPACER, PEDAL STRUT, YOKE TRANSMISSION

PART NUMBER: RS2081
 REVISION: G
 DATE: 06/07/2022
 BY: SP

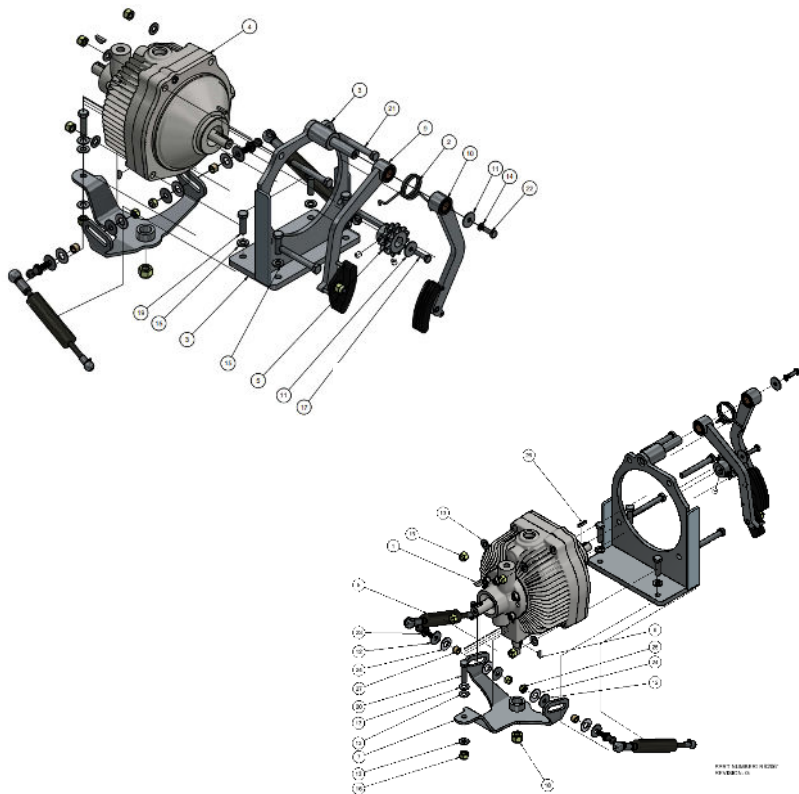

Assembly, Chain Tensioner Arm - LH

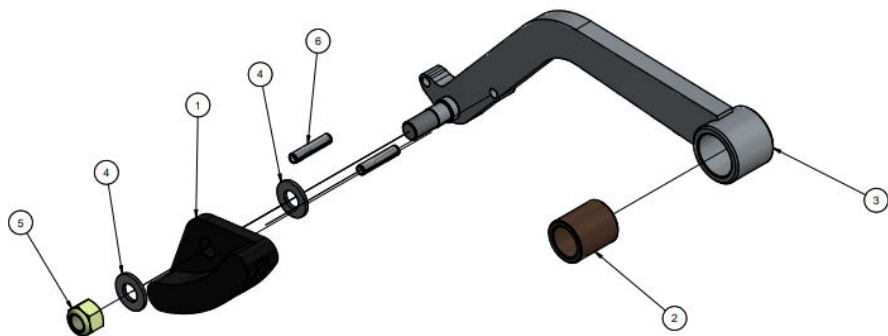

PARTS LIST			
ITEM	QTY	PART NUMBER	DESCRIPTION
1	1	EL510	CHAIN TENSION GUIDE
2	1	R5099	BUSH, BRONZE, CHAIN TENSIONER ARMS
3	1	R5132	ARM, CHAIN TENSION, WELDED, ASSY
4	2	R8048	3/8" X 3/4" FLAT WASHER, ZP
5	1	R8055	3/8" UNF NYLOC NUT, ZP
6	2	R8293	PIN, ROLL, SPRING, ZP - M5 x 24 LG

PART NUMBER: R5251
REVISION: B
DATE: 28/12/2020
BY: SP

PART NUMBER: R5251
REVISION: B

Assembly, Chain Tensioner Arm - RH

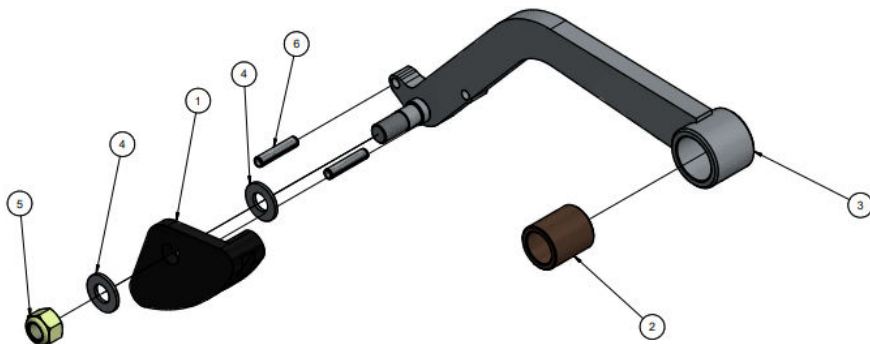

PARTS LIST				
ITEM	QTY	PART NUMBER	DESCRIPTION	
1	1	EL510	CHAIN TENSION GUIDE	
2	1	R5099	BUSH, BRONZE, CHAIN TENSIONER ARMS	
3	1	R5132	ARM, CHAIN TENSION, WELDED, ASSY	
4	2	R8048	3/8" X 3/4" FLAT WASHER, ZP	
5	1	R8055	3/8" UNF NYLOC NUT, ZP	
6	2	R8293	PIN, ROLL, SPRING, ZP - M5 x 24 LG	

PART NUMBER: R5251_1

REVISION: B

DATE:

BY: SP

PART NUMBER: R5251_1
REVISION: B

Assembly, Steering - Overlapping Heads

PARTS LIST			
ITEM	QTY	PART NUMBER	DESCRIPTION
1	2	RS266	BEARING, UCP204, PILLOW BLOCK ASSY
2	4	R8048	3/8" X 3/4" FLAT WASHER, ZP
3	12	R8055	3/8" UNF NYLOC NUT, ZP
4	8	R8069	3/8" UNF X 1-1/4" SET SCREW, ZP
5	4	R8070	3/8" UNF X 1-1/2" SET SCREW, ZP
6	2	RS2059	CAP. SHS END, PLASTIC, BLACK - 1.5" SQ.
7	1	RS2060	ASSEMBLY, TIE ROD ASSY, 1/2" UNF
8	1	RS2431	ASSEMBLY, SMOOTHING HEAD, FRONT
9	1	RS2432	ASSEMBLY, SMOOTHING HEAD, REAR
10	1	RS2438	WELDMENT, PIVOT BEAM
11	1	RS2444	ASSEMBLY, STEERING ROD, 1/2" UNF

PART NUMBER: RS2430
 REVISION: B
 DATE: 11/02/2021
 BY: SP

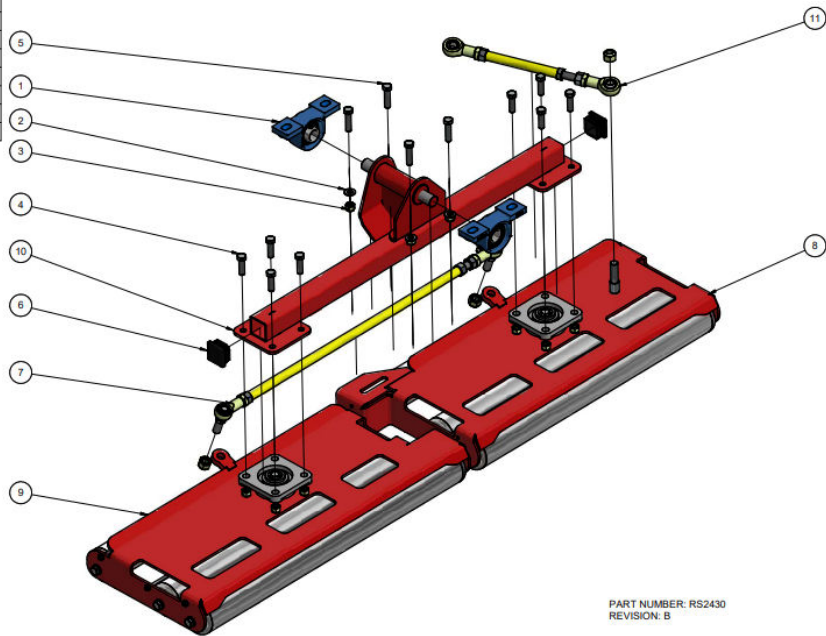

PART NUMBER: RS2430
 REVISION: B

Assembly, Front Smoothing Head

PARTS LIST			
ITEM	QTY	PART NUMBER	DESCRIPTION
1	1	R5263	BEARING UNIT ASSY - UCF205
2	4	R8052	3/8" SPRING WASHER, ZP
3	1	R8066	3/8" UNF X 3/4" BOLT, ZP
4	3	R8067	3/8" UNF X 1" BOLT, ZP
5	1	R8101	1/2" UNF NYLOC NUT, ZP
6	3	R8158	3/8" UNF X 1" FLAT HEAD SOCKET SCREW, ZP
7	2	R8201	ROD, SCRAPER - 3/16" Dia.
8	2	R8217	SMOOTHING ROLLER COMPLETE ASSY
9	1	R8225	WASHER, MOULDED, RUBBER, DAMPNER
10	3	R8250	NUT, HEX, NYLOC, SS - 3/16" UNF
11	1	R9457	SCRAPER, SMOOTHING ROLLER
12	1	RS2050	SMOOTHING ROLLER, LONG, COMPLETE ASSY
13	1	RS2182	SPACER, STEERING, HEAD & ARM
14	1	RS2433	WELDMENT, SMOOTH HEAD, FRONT

PART NUMBER: RS2431
 REVISION: B
 DATE: 11/02/2021
 BY: SP

Note: Scraper Rods Items 7, 10 & 11 are optional extras.

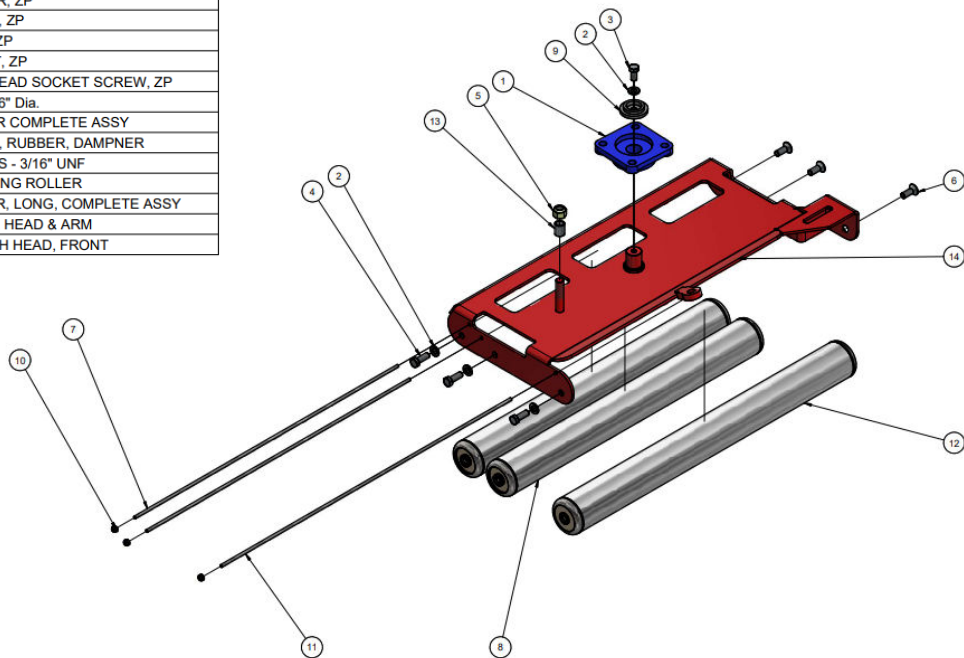

PART NUMBER: RS2431
 REVISION: B

Assembly, Rear Smoothing Head

PARTS LIST			
ITEM	QTY	PART NUMBER	DESCRIPTION
1	1	R5263	BEARING UNIT ASSY - UCF205
2	4	R8052	3/8" SPRING WASHER, ZP
3	1	R8066	3/8" UNF X 3/4" BOLT, ZP
4	3	R8067	3/8" UNF X 1" BOLT, ZP
5	3	R8158	3/8" UNF X 1" FLAT HEAD SOCKET SCREW, ZP
6	2	R8201	ROD, SCRAPER - 3/16" Dia.
7	2	R8217	SMOOTHING ROLLER COMPLETE ASSY
8	1	R8225	WASHER, MOULDED, RUBBER, DAMPNER
9	3	R8250	NUT, HEX, NYLOC, SS - 3/16" UNF
10	1	R9457	SCRAPER, SMOOTHING ROLLER
11	1	RS2050	SMOOTHING ROLLER, LONG, COMPLETE ASSY
12	1	RS2434	WELDMENT, SMOOTH HEAD,REAR

PART NUMBER: RS2432
 REVISION: C
 DATE: 11/02/2021
 BY: SP

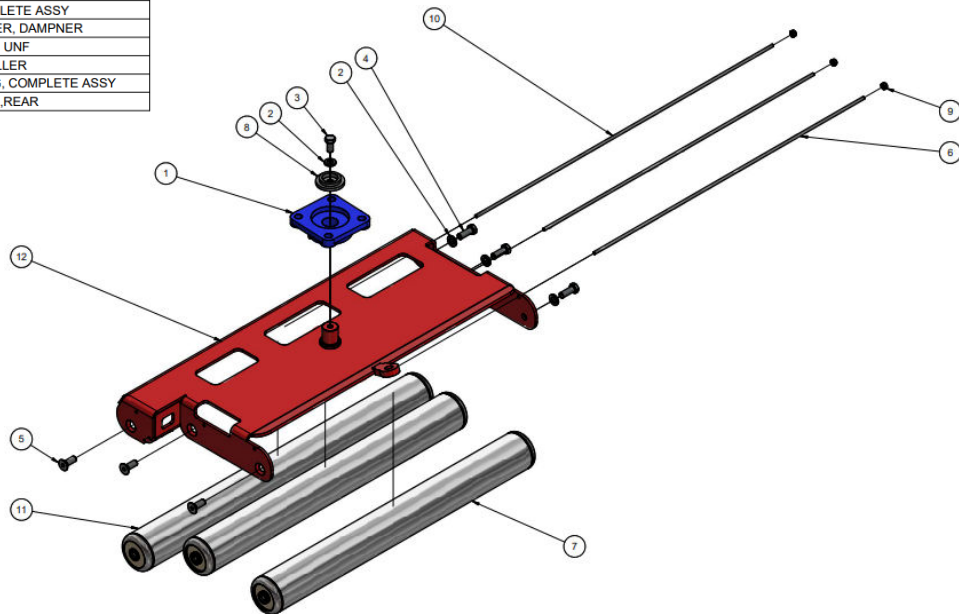

Note: Scraper Rods: Items 6, 9 & 10 are optional extras.

PART NUMBER: RS2432
 REVISION: C

Connecting Rods

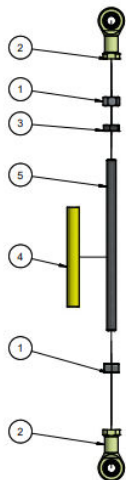

RS2444 - PARTS LIST			
ITEM	QTY	PART NUMBER	DESCRIPTION
1	2	R8284	1/2" UNF NUT, ZP
2	2	R8285	1/2" UNF ROD END, FEMALE, ZP
3	1	R8352	NUT, HEX, JAMB, ZP - 1/2" UNF
4	1	RS2445	TUBE, TIE ROD, STEERING
5	1	RS2446	ROD, THREADED, 1/2" UNF

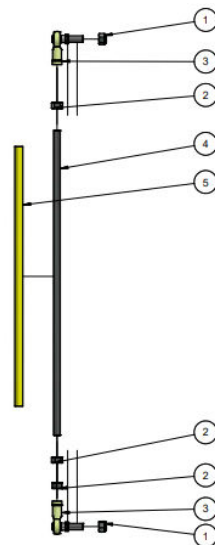

RS2060 - PARTS LIST			
ITEM	QTY	PART NUMBER	DESCRIPTION
1	2	R8101	1/2" UNF NYLOC NUT, ZP
2	3	R8284	1/2" UNF NUT, ZP
3	2	R8287	1/2" UNF ROD END, MALE
4	1	RS2090	THREADED ROD, STEERING BRACE
5	1	RS2091	TUBE, STEERING BRACE

PART NUMBER: RS2060
 REVISION: C
 DATE: 11/02/2021
 BY: SP

Assembly, Joystick

PARTS LIST			
ITEM	QTY	PART NUMBER	DESCRIPTION
1	1	R5009	GRIP, JOYSTICK - 27mm Dia.
2	1	R5049	SPRING, EXTENSION, ZP - Ø1/2"x18g.x5" LG
3	1	R5156	1/8" X 5/8" WOODRUFF KEY
4	1	R6009	JOYSTICK SHAFT, WELDED, ASSY
5	1	R6056	WELDMENT, JOYSTICK, COMPACT
6	2	R8018	BALL BEARING S6304-2RS, SS
7	2	R8055	3/8" UNF NYLOC NUT, ZP
8	1	R8060	1/2" UNC NYLOC NUT, ZP
9	2	R8070	3/8" UNF X 1-1/2" SET SCREW, ZP
10	1	R8101	1/2" UNF NYLOC NUT, ZP
11	1	RS2451	WELDMENT, STEERING ARM

PART NUMBER: RS2450
REVISION: B
DATE: 11/02/2021
BY: SP

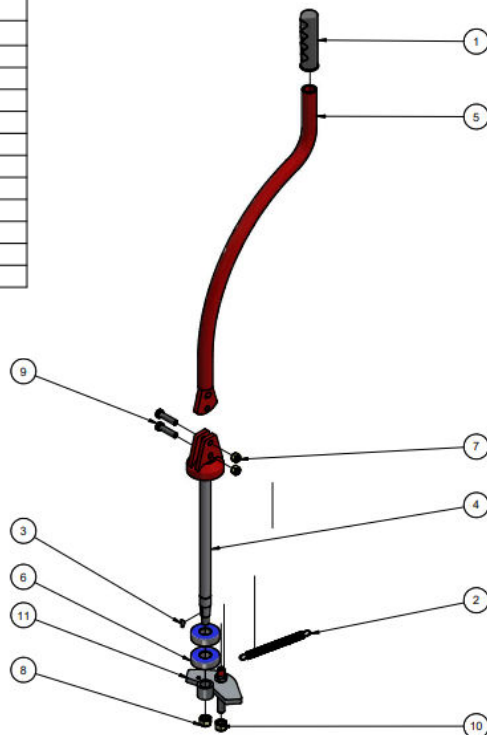

PART NUMBER: RS2450
REVISION: B

Assembly, Trailer

PARTS LIST			
ITEM	QTY	PART NUMBER	DESCRIPTION
1	2	E7007	BUSH, FLANGED
2	1	R5210	GAS STRUT ASSY
3	1	R8036	M2.5 x 20 SPLIT PIN, ZP
4	1	R8038	M10 X 40 BOLT, ZP
5	5	R8048	3/8" X 3/4" FLAT WASHER, ZP
6	2	R8055	3/8" UNF NYLOC NUT, ZP
7	2	R8072	BOLT, HEX, ZP - 3/8" UNF x 2.5 LG
8	2	R8082	CIRCLIP, EXT, BLK, 30mm
9	1	R8088	M10 NUT ZP
10	1	R9018	TRAILER ARM, LH, ASSY
11	1	R9019	TRAILER ARM, RH, ASSY
12	2	R9037	WHEEL HUB COMPLETE PARALLEL AXLE
13	2	R9074	WHEEL, 4 STUD, 18" TYRE
14	1	R9472	WELDMENT, DRAW BAR, COMPACT
15	2	RS2424	BUSH, FLANGED, CHAMFERED

PART NUMBER: R9460
 REVISION: A
 DATE: 11/02/2021
 BY: SP

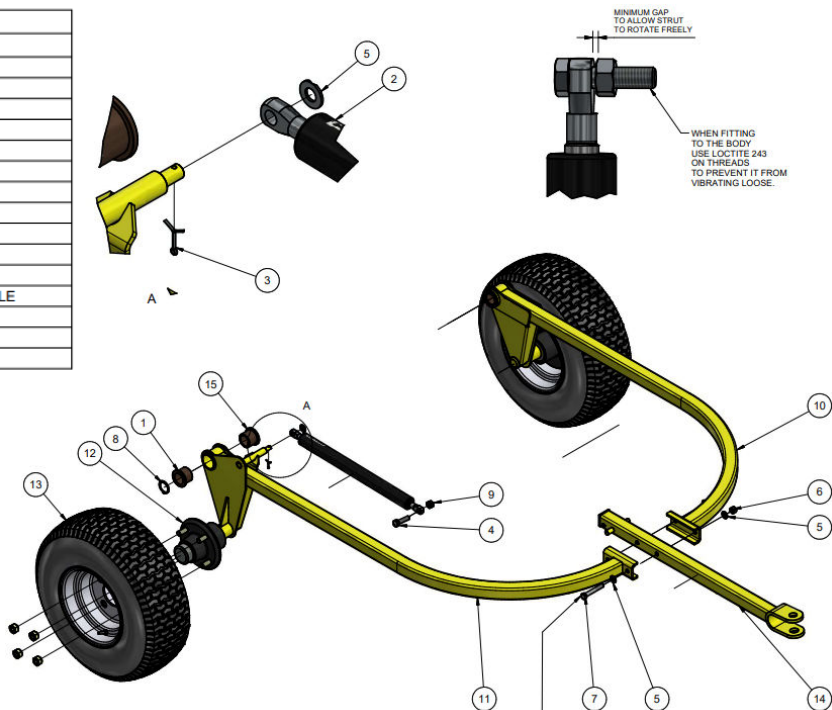

WHEN TRAILER DRAWBAR IS BEING ASSEMBLED THESE BOLTS & NUTS MUST BE CORRECTLY TIGHTENED TO 47 ft-lbs OR 63.7 Nm. IF NOT THE DRAWBAR CAN BECOME LOOSE AND THE HOLES WILL WEAR MAKING IT DANGEROUS WHEN TOWING OR RAISING / LOWERING THE TRAILER.

PART NUMBER: R9460
 REVISION: A



Assembly, Trailer Hub

R9037 TRAILER HUB PARALLEL AXLE COMPLETE ASSY - PARTS LIST			
ITEM	QTY	PART NUMBER	DESCRIPTION
1	1	R9035	CAP. HUB BEARING
2	1	R9034	PIN, COTTER, STUB (SPLIT) - M4 x 40
3	4	R9036	NUT, WHEEL, 1/2" UNF (USA)
4	1	R9029	SEAL, INNER HUB - CR 12610
5	2	R9030	BEARING, TAPERED ROLLER - L44643
6	1	R9032	WASHER, STUB AXLE (19x38)
7	1	R9033	NUT, CASTLE, STUB AXLE - 3/4"-16 UNF
8	1	R9038	HUB, TRAILER, PARALLEL AXLE

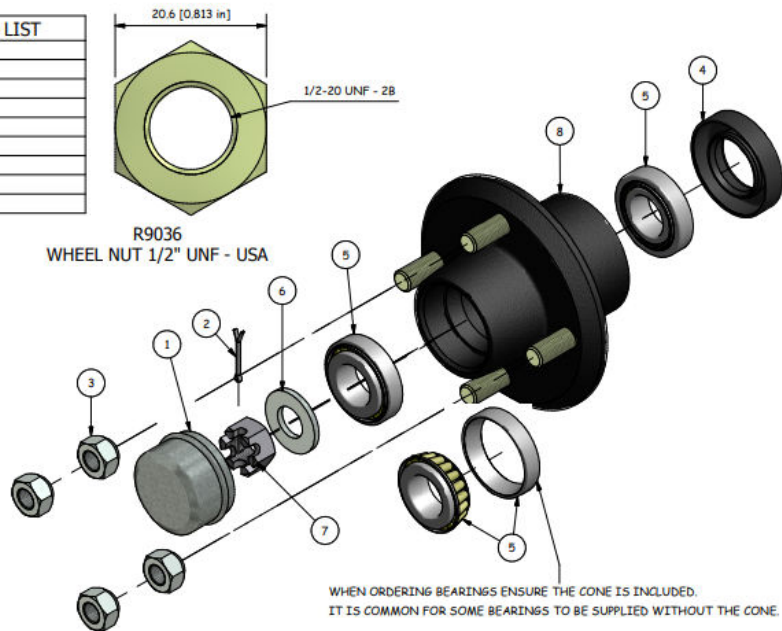

NOTE: R9037 HUB IS PURCHASED AS A COMPLETE ASSEMBLY ITEM

Assembly, Seat & Frame

PARTS LIST			
ITEM	QTY	PART NUMBER	DESCRIPTION
1	1	E7067	SWITCH, LIGHT
2	1	R5129	METER, HOUR, TACHO
3	1	R6013	BUFFER STOP, UNDER BODY
4	2	R8048	3/8" X 3/4" FLAT WASHER, ZP
5	4	R8051	5/16" SPRING WASHER, ZP
6	3	R8052	3/8" SPRING WASHER, ZP
7	2	R8055	3/8" UNF NYLOC NUT, ZP
8	5	R8067	3/8" UNF X 1" BOLT, ZP
9	1	R8256	M8 NYLOC NUT, ZP
10	1	R8365	MISCO SEAT ALL PVC WITH ARMS MSC
11	4	R8484	5/16" UNC X 1" BOLT, ZP
12	2	R8497	4-8 RIVET, ALUMINIUM
13	1	R9484	WELDMENT, SEAT FRAME
14	1	R9485	WELDMENT, SEAT BASE

PART NUMBER: R9450
 REVISION: B
 DATE: 11/02/2021
 BY: SP

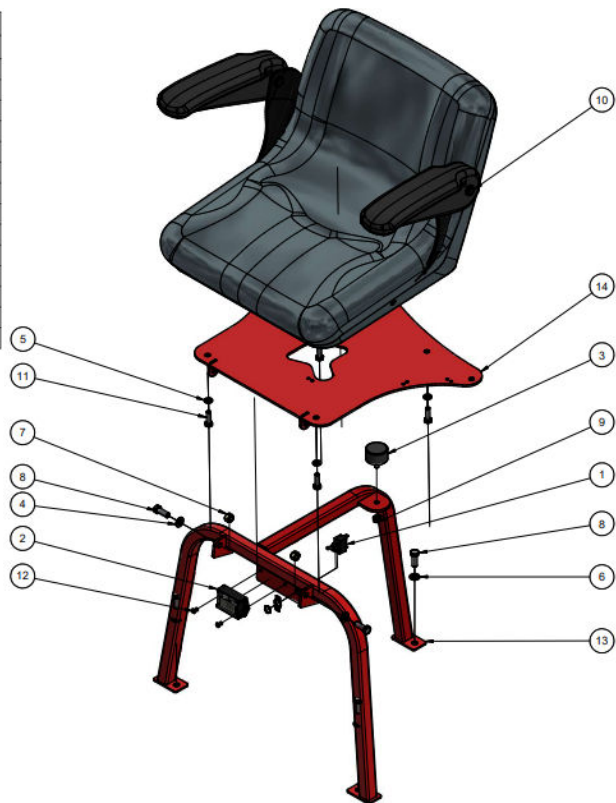

PART NUMBER: R9450
 REVISION: B

Assembly, Seat

R8365 MILSCO SEAT ALL PVC WITH ARMS - PARTS LIST			
ITEM	QTY	PART NUMBER	DESCRIPTION
1	1	R8362	SEAT, ALL PVC PAN ONLY - MILSCO
2	1	R8363	ARM REST, RH, ASSY, MILSCO
3	1	R8364	ARM REST, LH, ASSY, MILSCO

FITTING INSTRUCTIONS

NOTE: WHEN FITTING THIS SEAT TO THE BASE PLATE
THE RECOMMENDED DYNAMIC TORQUE FOR THE SEAT
BOLTS IS 80±15 IN.LBS (DO NOT EXCEED 180 IN.LBS)
ARMREST BRACKET BOLTS IS 70±10 IN.LBS

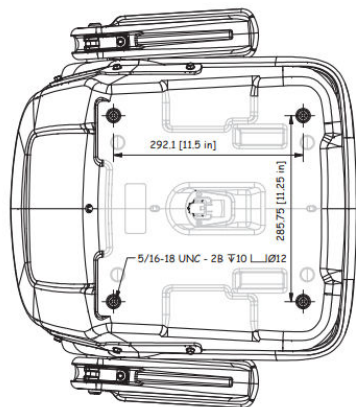

BOTTOM VIEW

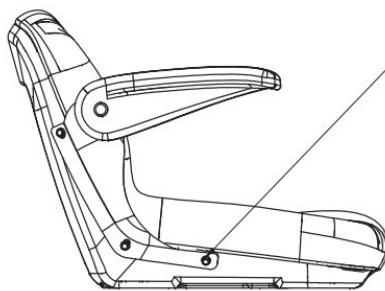

SIDE VIEW

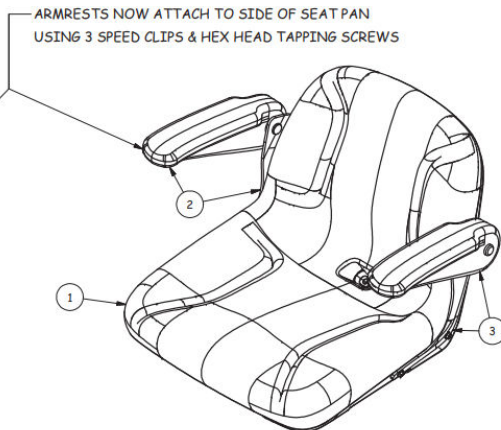

Harness Loom

SCHEMATIC DIAGRAM OF SAFETY INTERLOCK CIRCUIT & OPERATOR PRESENCE SYSTEM – MILSCO SEAT

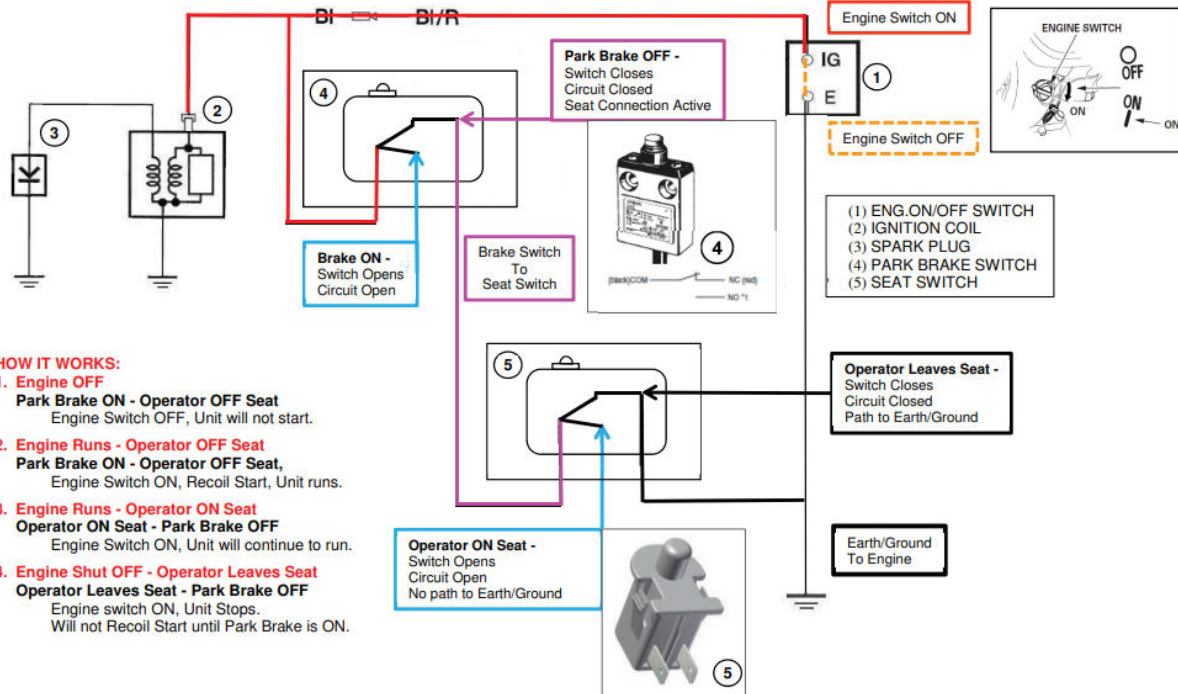

Troubleshooting: Roller

Roller will not move one or either way, check:

- Engine is running.
- Ignition is on.
- Belt is correctly fitted and tensioned.
- Sprockets are not worn or slipping on the shaft.
- Foot control is operating correctly.
- For sheared sprocket keys.
- Rubber coupling broken

Roller will not steer, check:

- Woodruff key is in place and not sheared.
- Rod ends are connected to smoothing roller head and the steering arm.
- Rod ends are not broken or seized.
- Swivel bearing on connecting the smoothing roller head to the pivot beam, have not seized.
- Connecting rods are in place and serviceable.

Roller has excessive vibration, check:

- Disconnect engine-to- transmission and isolate the drive chain to determine whether the problem is in the engine or in the transmissions.
- If engine is at fault, contact your nearest engine agent for rectification.
- If the transmission is at fault, repair or replace as necessary, or seek professional advice from a local Eaton Service Centre.
- Any out of alignment between engine and transmission.
- For damaged engine and transmission couplings



Troubleshooting: Roller

Smoothing rollers seized, check:

- Bearings are OK and not rough or seized.
- Replace if necessary.
- Accumulated dry debris is not locking the smoothing rollers.

Rubber drive roller will not rotate, check:

- Roller shaft end bearings have not seized.
- Broken chain
- Slipping sprockets
- The park brake is not locked on



Available Spare Parts

For spare parts, click the following link: [Spare Parts](#)

