

Operator Manual & Parts List

MAJOR RANGE OF
TDR ROLLERMOWERS
TDR 16000
TDR 20000



Head Office

Major Equipment Intl. Ltd.,
Ballyhaunis,
Co. Mayo,
Ireland.

Tel.: +353 (0) 9496 30572
Fax: +353 (0) 9496 30788
Email: info@major-equipment.com

UK Office

Major Equipment Ltd.
Major Industrial Estate,
Middleton Rd.,
Heysham,
Lancs.
LA3 3JJ

Tel.: +44 (0) 1524 850 501
Fax: +44 (0) 1524 850 502
Email: ukinfo@major-equipment.com

NL & GERMANY OFFICE

Major Equipment Intl. Ltd.,
Postbus 29,
NL-7700 AA,
Dedemsvaart,
Nederland.

Tel: +31 (0) 6389 19585
Email: euinfo@major-equipment.com

Web: www.major-equipment.com



Find us on Facebook
Search for "Major Machinery"



Visit our channel MAJOREQUIPMENT on www.youtube.com

Disclaimer

While every effort has been made in the production of this manual to ensure that the information contained herein is full and correct, Major assumes no responsibility for errors or omissions.

Major reserves the right to modify the machinery and the technical data contained within the manual without prior notice.

Further to this, Major assumes no liability for any damages which may result from the use of the information contained within this manual.

Contents

Introduction

Thank you	1
Using Your Operator's Manual	1
Safety Aspects	1

Product Identification

Machine Serial Numbers	1
Product Specifications	1
Register Your Product and Warranty Online	1

Safety

Machine Safety Labels	2
Operating Safely	2
Workstation	3
Regulations for use of the transmission	3
PTO Shaft Safety	3
Driving Safely on Public Roads	4

Operating the Machine

Inspections before Use	4
Key to Main Parts	5
Starting Regulations	6
Hitching to the Tractor	6
Blade Rotations	9

Maintenance

PTO Shaft Maintenance	9
Belt Adjustment	10
Belt Removal & Fitting	10
Wheel nuts	11
Taper Bush Installation	11
Taper Bush Removal	11
Maintenance Schedule	12
Trouble Shooting	13

Spare Parts

TDR Spare Parts	15
Axles	21
Hose Assemblies	25
Blades	27
PTO Shafts	32
Gearboxes	32

EEC certificate of conformity for machines

(conforming to Directive 98/37/EEC)

Company: Major Equipment Ltd.
Address: Coolnaha,
Ballyhaunis,
Co. Mayo,
Ireland.
Tel. +353949630572
Fax +353949630788

declares in sole responsibility that the product:

TDR ROLLERMOWER

When properly installed, maintained and used only for it's intended purpose, complies with all the essential Health & Safety requirements of:

- **THE SUPPLY OF MACHINERY (SAFETY) REGULATIONS 2008.**
- **S.I. No. 299 of 2007**, Safety, Health and Welfare at Work (General Application) Regulations 2007 (Ireland).
- **Health & Safety at Work, etc. Act 1974 (c.37) (UK).**
- **EN ISO 14121-1: 2007** 'Safety of machinery. Principles for risk assessment'.
- **EN 745** - Agricultural Machinery - Rotary Mowers and Flail Mowers - Safety.
- **EN ISO 13857** - Safety of machinery: Safety distances to prevent hazard zones being reached by upper and lower limbs.

I certify on behalf of Major Equipment Int. Ltd., that this machine when properly installed and operated correctly, complies with all the essential Health & Safety requirements of all legislation referred to above.

Signature :



Managing Director

Date 12/01/2012

Introduction

Thank you

We appreciate having you as a customer and wish you many years of safe and satisfied use of your machine.

Using Your Operator's Manual

This manual is an important part of your machine and should remain with the machine when you buy it. Reading your operator's manual will help you and others avoid personal injury or damage to the machine. Information given in this manual will provide the operator with the safest and most effective use of the machine.

Sections in your operator's manual are placed in a specific order to help you understand all the safety messages so you can operate this machine safely. You can also use this manual to answer any specific operating or servicing questions.

Safety Aspects

Your manual contains special messages to bring attention to potential safety concerns, machine damage as well as helpful operating and servicing information. Please read all the information carefully to avoid injury and machine damage.

Product Identification

Machine Serial Numbers

If you need to contact MAJOR or your MAJOR dealer for information on servicing or spare parts, always provide the product model and serial numbers.

We suggest that you record your machine details below:

Model No: _____ Serial No: _____ Date of Purchase: _____

Dealer Name: _____ Dealer Telephone: _____

Product Specifications

Model	TDR16000	TDR20000
Working Width	4.9m	6.1m
Overall Width	5m	6.24m
Transport Length	3.66m	3.66m
Transport Width	2.53m	2.53m
Transport Height	2.37m	3m
Wing Float	25° down/10° forward/back/90° up	
Cutting Height	12 - 150mm	
Blade tip speed	4569 m/min	4569 m/min
Power (HP)	65-90	75-100
Rotors	8	10
Tyre Pressure	40psi	50 psi
Gearbox Oil	EP 90 gear oil	
Weight	2260kg	2675kg

Register Your Product and Warranty Online

To register your product through the Internet, simply go to the Support section on www.major-equipment.com. Completing the information, either online or with the product warranty card, will ensure the customer that their product receives all post sales service and important product information.

Safety

Machine Safety Labels

The machine safety labels shown in this section are placed in important areas on your machine to draw attention to potential safety hazards.

On your machine safety labels, the words DANGER, WARNING, and CAUTION are used with this safety-alert symbol. DANGER identifies the most serious hazards.

The operator's manual also explains any potential safety hazards whenever necessary in special safety messages that are identified with the word, CAUTION, and the safety-alert symbol.

Operating Safely

This machine is a result of continuous research, development and quality testing. Please treat it accordingly. The MAJOR TDR Rollermower is designed to operate at 540 RPM. Ensure tractor PTO output is set at 540 RPM. The MAJOR TDR Rollermower must only be used for cutting grass. Moreover, it must only be used with a suitable tractor (see product specifications) and driven by an adequate drive-line by the tractor PTO. All other use is strictly prohibited.



To prevent Serious Injury or Death

- Avoid unsafe operation or maintenance.
- Do not operate or work on this machine without reading and understanding the operator's manual.
- If manual is lost, contact your nearest dealer for a new manual.



To avoid injury, read the manual

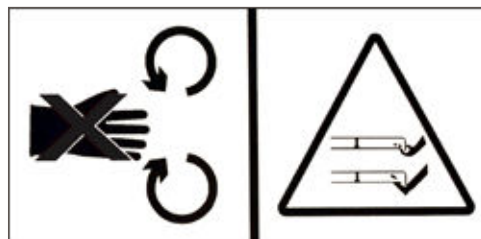

Rotating blade hazard



Moving parts hazard

Fold PTO stand down before removing transport pin, otherwise PTO shaft will be damaged!

Fold the PTO stand down before removing the transport pin to avoid PTO shaft damage



PTO entanglement hazard - keep clear of PTO drives.



High oil pressure hazard

Users should become thoroughly familiar with the contents of this manual before using, servicing and mounting the implement to the tractor and all other pertinent operations. Never wear jewellery, loose clothing such as ties, scarves, belts, unbuttoned jackets or dungarees with open zips which could become caught up in moving parts.

Always wear approved garments complying with accident prevention provisions such as nonslip shoes, ear muffs, goggles and gauntlets. Wear a jacket with reflecting stickers if the implement is used near public highways.

Consult your retailer, the Labour Health Service or your nearest equivalent authority for the information about the current safety provisions and specific regulations with in order to ensure personal safety.



ALWAYS DISENGAGE PTO, SWITCH OFF THE TRACTOR ENGINE AND ENGAGE THE PARKING BRAKE BEFORE MAKING ADJUSTMENT TO THE MACHINE.



NEVER PLACE LIMBS UNDER THE MACHINE WHILE ROTORS ARE TURNING. ROTORS CAN REMAIN TURNING FOR UP TO 1 MINUTE AFTER DISENGAGING PTO.

Workstation

The operator must remain seated while working the machine. When the wings need to be raised and lowered the operator must leave the tractor. Always ensure the PTO has been turned off and the parking brake applied before leaving the tractor cab. The operator must always apply the parking brake, and turn off the engine before leaving machine or carrying out maintenance.



NEVER OPERATE THE HYDRAULICS WITH THE TRACTOR SWITCHED OFF

Regulations for use of the transmission

The transmission to the gearboxes is protected throughout the machine by both PTO shafts and bolt down covers. All guarding should be kept efficient and in good condition. If the condition is poor, the guarding should be renewed before the implement is used.



UNLESS IT IS CORRECTLY PROTECTED THE TRANSMISSION COULD CAUSE DEATH SINCE IT CAN CATCH ON PARTS OF THE BODY OR CLOTHING

Ensure retaining chains are correctly anchored on all PTO shafts, preventing them from turning. Ensure drive line can turn easily within the shield. Keep spline grooves clean and greased so that PTO shaft can connect easily. Besides being described in this manual, the method by which the PTO shaft is connected to the tractor must be checked out with the instructions in the tractor manufacturer's manual.

PTO Shaft Safety



MAX PTO INPUT 540 RPM Contact your nearest dealer or a specialised retail outlet if the PTO must be replaced with a longer one, since this must belong to the same power category and possess the same characteristics. An unsuitable PTO could easily break.

The tractor PTO shaft length may be altered to suit the individual tractor model. When the machine is in operation, the PTO shaft should have a minimum 1/3 engagement as shown in the diagrams. After the TDR Rollermower has been hitched to the tractor, it should be checked in various positions that the drive line is the correct length. If the PTO is too short and tends to slip out of place, it must be replaced with a longer one.

If the PTO shaft is too long, it should be shortened in the following way:

- Set the machine at a minimum distance from the tractor, then brake the tractor and switch off the engine.
- Separate the two halves of the PTO. Insert the female part into the tractor PTO and the male part into the TDR Rollermower PTO, checking that the position is correct by means of the fixing pins.
- Line up the two halves of the PTO together, keeping them parallel.
- Using a felt tip pen, match mark the place where the two halves must be shortened as shown.
- First cut shield "1" and use part "2" as a reference to cut the splined shaft.
- Proceed in the same way for the second half.
- Trim and chamfer the two cut ends of the PTO and clean off all swarf and shavings.
- Grease the two profiles and join the two halves of the PTO together.
- Mount the PTO shaft and check that its length is correct as before.

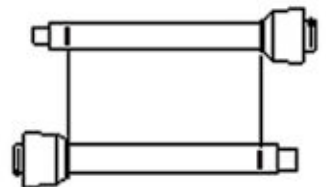
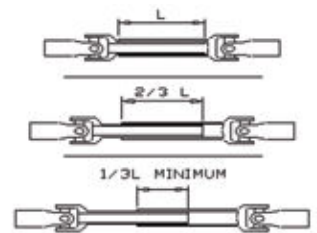

The shaft must not reach the end of the tube or project from this. Ensure the PTO does not bottom when turning.

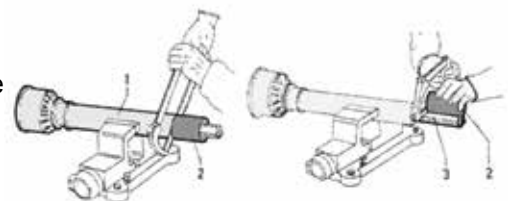

NOTE: TDR hitch is adjustable in length. Adjust the hitch to optimum position before cutting shaft.

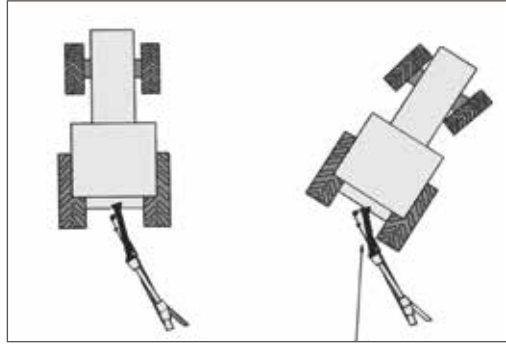

Driving Safely on Public Roads



Check the local Highway Code regulations before driving the tractor on public highways with a towed implement. Check the reflectors, hazard flashers and/or projecting load indicators are installed when required and efficient. These indicators must be installed correctly and easily seen by the drivers of other vehicles.

Bystanders must not be allowed to lean against or climb onto the machine during transport or while working. Do not allow bystanders to ride on the machine. **Maximum transport speed for the implement is 30km/h. DO NOT EXCEED**

- Check machine is hitched to the tractor as described. Ensure the tractor parking brake is applied
- Lift the two wings by hydraulic control & lock in position using the wing locking clamps.
- Use the retaining strap to fully secure wings.
- Lift the rear deck by hydraulic control and lock hydraulic pipes via the shutoff taps supplied for the rear deck.
- Attach hydraulic connections (check tractor manual for correct hydraulic layout i.e. open or closed circuits). The TDR Gang Mower is factory set for 'open' hydraulic circuits.
- Attach 12v lighting connection

Operating the Machine

Inspections before Use



Always disengage PTO, Switch off tractor engine and engage the parking brake before making adjustment to the machine.

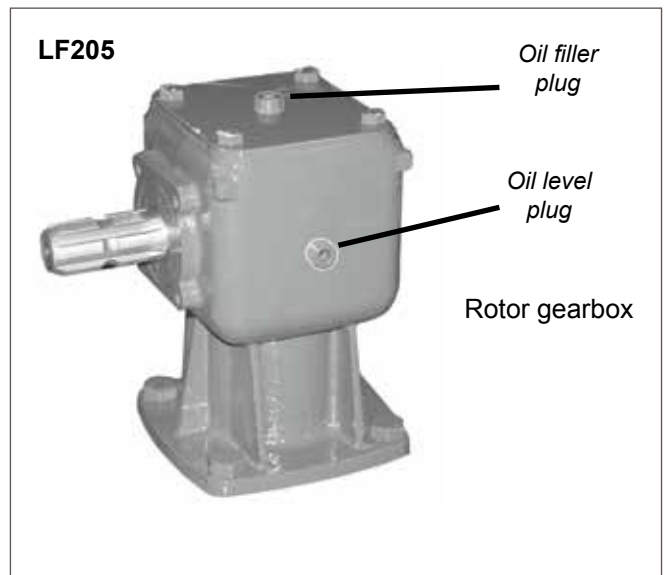
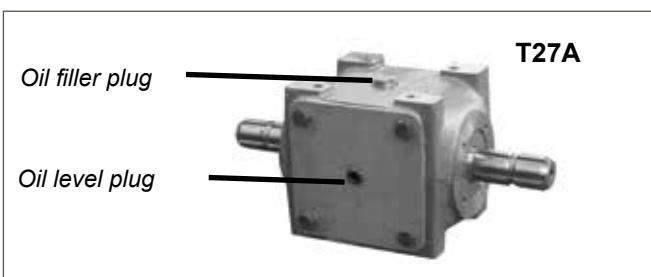
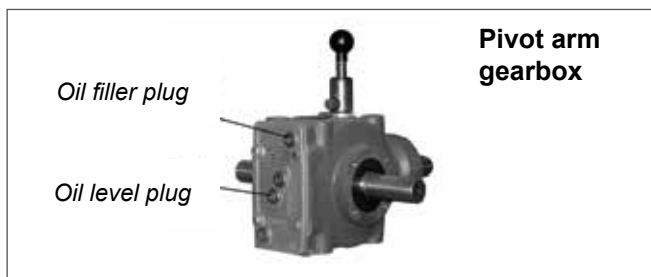

1. With the whole machine as level as possible, check the oil level in the Primary Gearbox, top up as required with SAE EP90 gear oil through the oil filler plug indicated. The correct level is at the oil level plug indicated. Check the oil level in the Rotor Gearboxes and top up as required with SAE EP 90 gear oil. Put it through the oil filler plugs indicated. The correct level is at the oil level plug indicated
2. Grease the PTO shaft universal joints, drive shaft bearing and carrying arm pivots.
3. Re-sharpen old blades with a grindstone if necessary. Replace bent blades with new ones.
4. Check the blade mounting bolts are tight

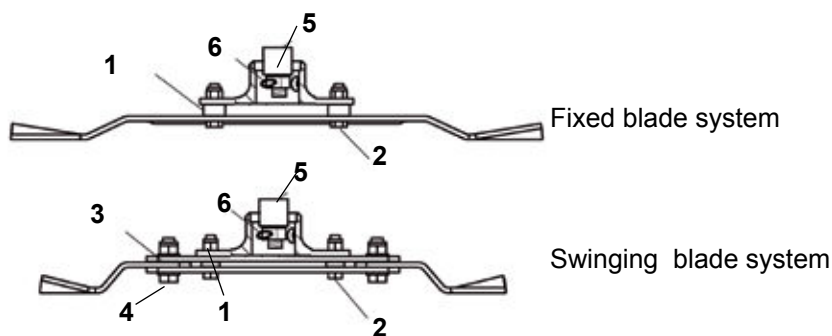

- 1 - Spacer bushings
- 2 - Blade mount bolts
- 3 - Blade pivot bush
- 4 - Blade pivot bolt
- 5 - Gearbox output shaft
- 6 - Split pin
- 7 - Retaining bolt
- 8 - Bolt

5. Ensure the gearbox shaft nuts are tight and retained in place by split pin.
6. Check tightness of all nuts, bolts and retaining screws after the first and second hours of work.
7. Ensure safety guards and flaps are in place at all times where fitted.
8. Due to the corrosive nature of grass when cut, wash down the machine when finished mowing, especially when the machine is being stored for a long period of time.

Key to Main Parts

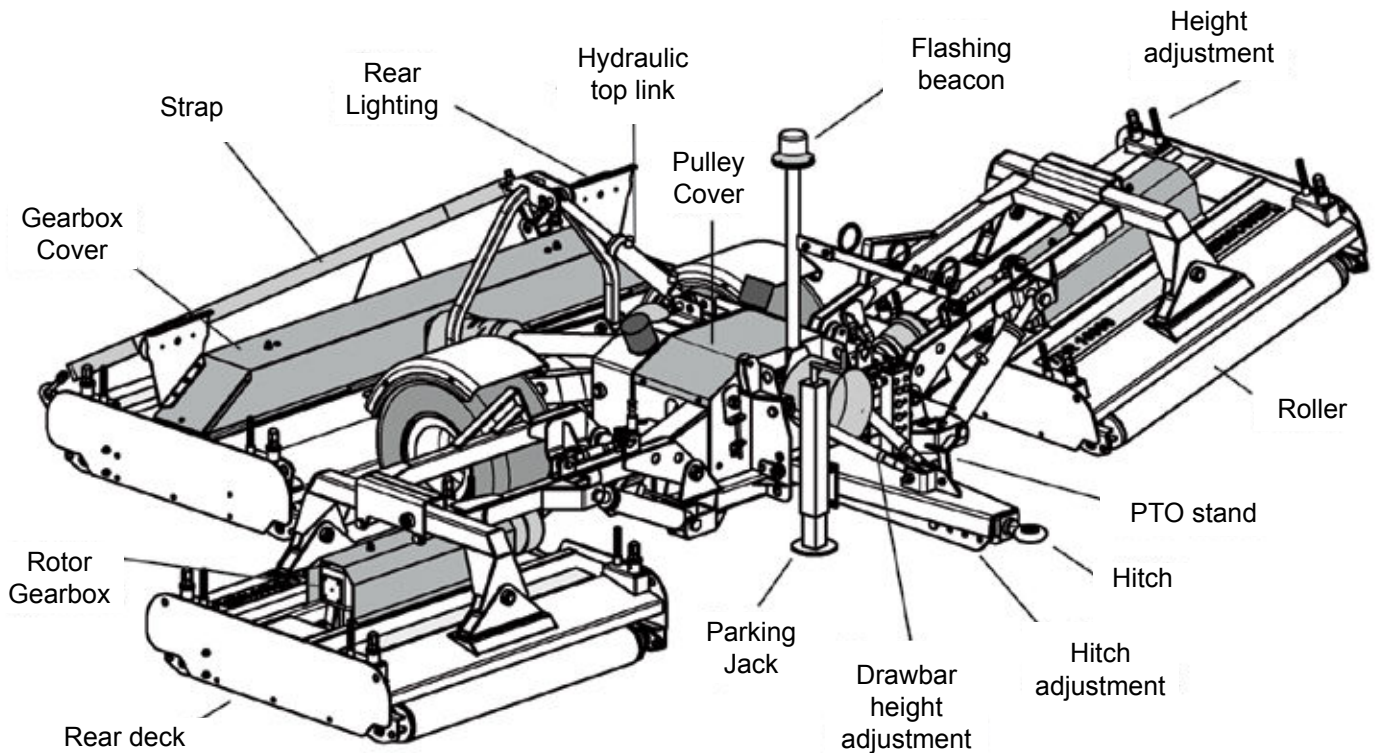

Starting Regulations

Always check that any imminently dangerous conditions have been eliminated before using the machine. Ensure all guarding is present & the operator is fully aware of the operations of the machine

Always ensure the pins lock the PTO shaft yoke ends onto the spline shafts on both the tractor and the implement. An unlocked shaft could slip out of position, causing notable mechanical damage and serious injury to both operator and bystanders.

Hitching to the Tractor

ALWAYS OPERATE ON LEVEL GROUND WHEN HITCHING/UNHITCHING THE IMPLEMENT. THIS WILL PREVENT DANGEROUS MOVEMENT. NEVER ALLOW ANYONE TO STAND BETWEEN THE TRACTOR AND THE TDR ROLLERMOWER.

1. Reverse the tractor, connect the hitch & secure in position with correct size drawbar pin
2. Ensure that the circlip is on top as shown below
3. Ensure the tractor brake is applied
4. Adjust the level of the drawbar until the main body is level.
5. Connect the hydraulic connections to the tractor.
6. Mount the solenoid control box in tractor cab.
7. Fit the PTO shaft & secure the PTO cover chains.
8. Raise the parking jack. Solenoid Control Box Mounting.
9. Adjust drawbar instead of cutting PTO shaft.

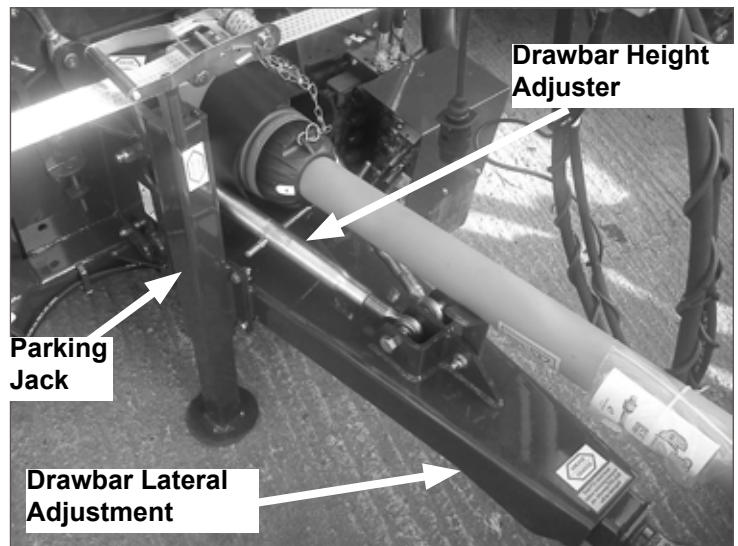
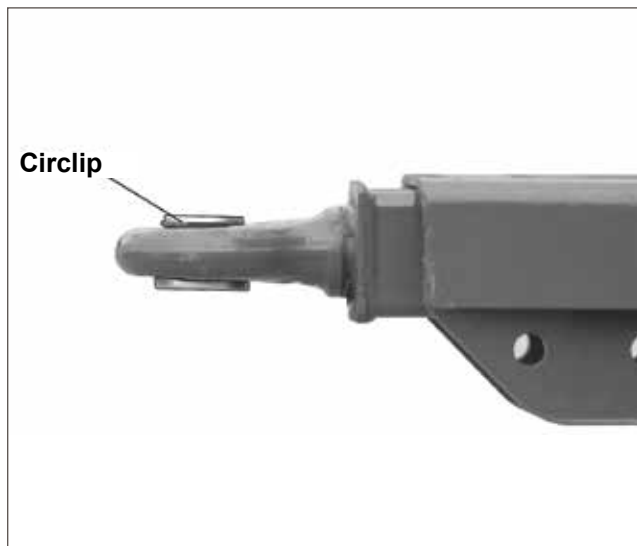

The MAJOR TDR Rollermower is designed to operate at a max 540-720 RPM. Always operate on level ground when hitching / unhitching the implement. This will prevent dangerous movement.

1. Never allow anyone to stand between the tractor and the machine.
2. Ensure the machine is hitched correctly to the tractor as previously described.
3. Ensure bystanders are clear from the machine & cannot be hit with debris expelled from the machine.
4. Unlock hydraulic arms supporting the rear deck, taking care not to stand between mainframe and rear deck.
5. Ensure cutting decks are lowered to the ground.
6. Place wing locking clamps in position 'X' as shown in the photo below.
7. Wing PTO drive will engage automatically selector knob 'Y'.
8. Start up the tractor PTO at a low RPM.
9. Build up to operating speed, select a suitable forward gear & proceed to cut grass. NOTE: The Selector knob is fitted with a spring 'Y' in order to auto stop wing rotors when raised.
10. Tighten both the Top Link Tap 'B' & Lower Link Arm tap 'A' to lock the rear deck when raised for transport.

NOTE: This machine is factory set to operate with 'open centre' hydraulic systems. When connecting to tractors with 'closed centre' hydraulics, the Pilot valve spool knob 'C' must be closed (screwed 'in').

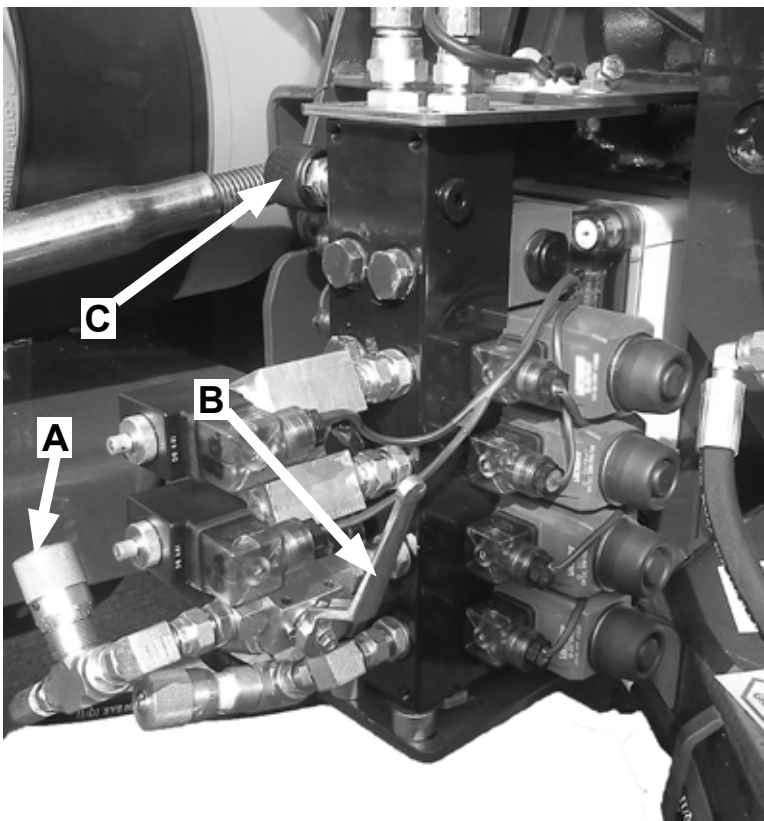
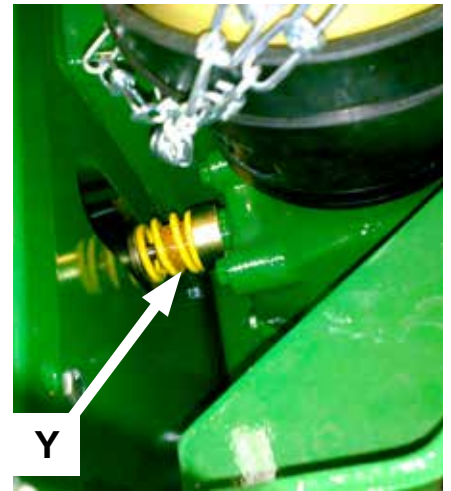
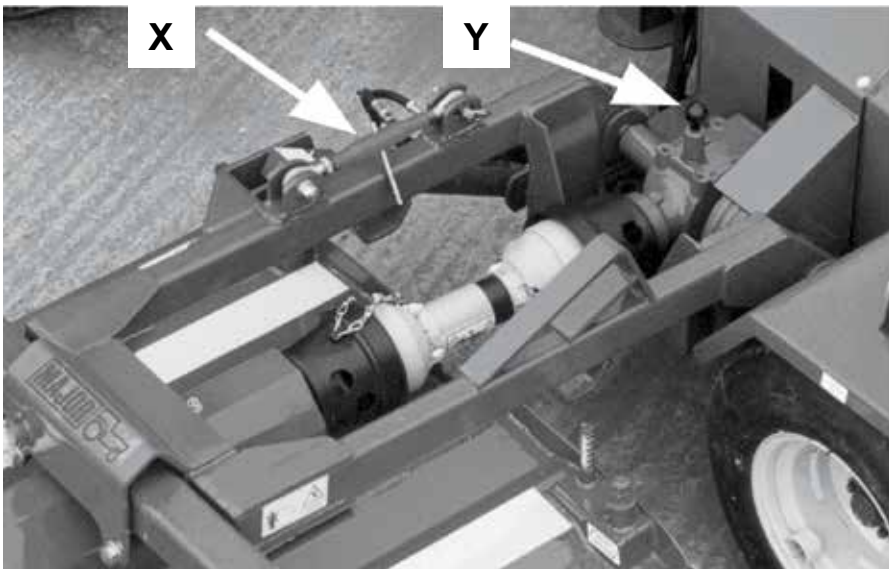

WARNINGS

ENSURE FREE FLOW RETURN IS CONNECTED. MINIMUM OIL FLOW IS 30 L/MIN.

Never place limbs under the machine while rotors are turning. Rotors can remain turning for up to 1 minute after disengaging.

Always disengage PTO, switch off tractor engine and engage the parking brake before making adjustments to the machine.

When using the machine with one or both wings in the raised position, ensure the drives to the wings are disengaged.

Ensure that rotors are still before raising/lowering wings and rear deck.

DO NOT lower wings while PTO is in motion as damage can occur to the wing input gearbox.

Remote Control

For your comfort this machine is operated via remote control.



Batteries

Charge connectors

Batteries



Base 12V charging unit

Plug

Remote Control

The following operations can be carried out by using the remote control:

1. Left wing Up, Left wing Down / Float

 By keeping this key pressed, the left wing rises up.

By releasing the key, the left wing stops.

 By keeping this key pressed, the left wing goes down and floats the same time. By pressing the key again, descent and floating stop. A red LED light indicates that the action is active (see diagram below).

3. Right Wing UP, Right Wing DOWN/Float

 By keeping this key pressed, the right wing rises up. By releasing the key, the right wing stops.

 By keeping this key pressed, the right wing goes down and floats the same time. By pressing the key again, descent and floating stop. A red LED light indicates that the action is active.

2. Rear deck UP, Rear deck DOWN/ Float

 By keeping this key pressed, the rear deck goes up.

By releasing the key, the rear deck stops.

 By keeping this key pressed, the rear deck goes down and floats the same time. By pressing this key again, descent and float stop. A red LED light indicates that the action is active.

4. Rear deck top link block, Rear deck top link transport

 By keeping this key pressed the rear deck top link blocks. By releasing this key, the rear deck top link unblocks.

 By keeping this key pressed the rear deck goes up/down. By releasing the key, the rear deck stops moving.

Manual override

In the event of Manual Override, in order to lower wings, please follow this procedure:

1. Turn off remote control (Disconnection is not necessary);
2. Press the black tap in and turn it clockwise (Figure A);
3. Turn the screw anti-clockwise until fully open (Figure B);
4. Press the button fully (Figure C).



Figure A



Press the knob in and turn



The knob will lock in this position



Figure B
Top screw (shown) - right wing.
Bottom screw - left wing.



This shows the normal position, threaded in.



This shows the manual override position with the thread out. IMPORTANT - The check will not work in this position & this should be used for maintenance purposes only. Manual override should not be used when operating the machine normally.

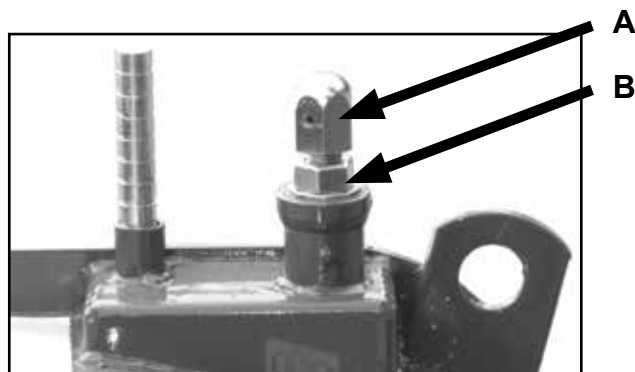

Figure C
Button shown will make the wing go down.
Button on the opposite side will raise the wing.

Adjusting the Rollers

- Slacken the Height adjuster stop lock nuts (B) and
- Adjust the roller adjuster (A) to obtain the desired cutting height.
- Tightly close the lock nut (B) again to keep the rollers in this position.

NOTE: IT IS IMPORTANT TO HAVE ROLLERS LEVEL AFTER ADJUSTMENT



Blade Rotations

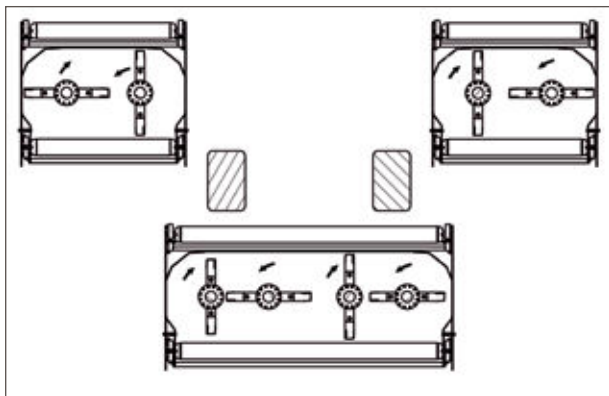

TDR16000 Blade rotations

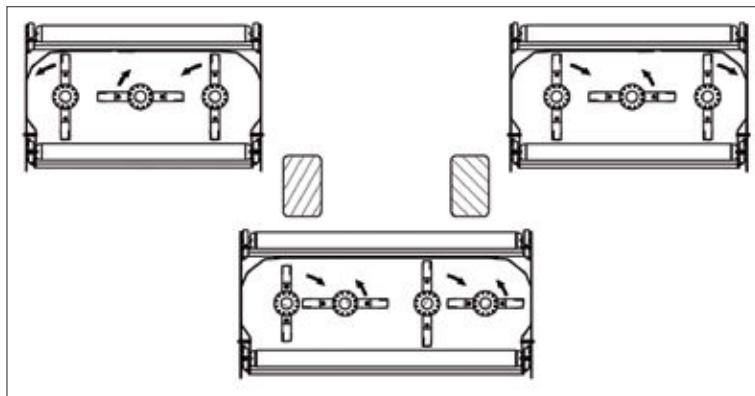

TDR20000 Blade rotations



Blades must always be timed at 90 degrees to each other as shown below. Failure to do so can cause the blades to foul and in turn may damage the transmission.

Maintenance

The machine must always be disconnected from the tractor before any cleaning, lubricating and servicing operations can be carried out. If emergency operations are required whilst the machine is connected to the tractor, switch off the engine, engage the parking brake and disengage the PTO. Good, regular maintenance and correct use are if the TDR Rollermower is to remain safe and long lasting.

Only trained and competent personnel should carry out major repairs on the machine. Do not attempt to repair the machine if you are unsure and contact your local dealer.

PTO Shaft Maintenance

Guard Removal and Yoke End Greasing

1. Prise back locking tabs
2. Pull back PTO Guard
3. Grease points as shown
4. Push Guard into position
5. Click into place
6. Tie check chain

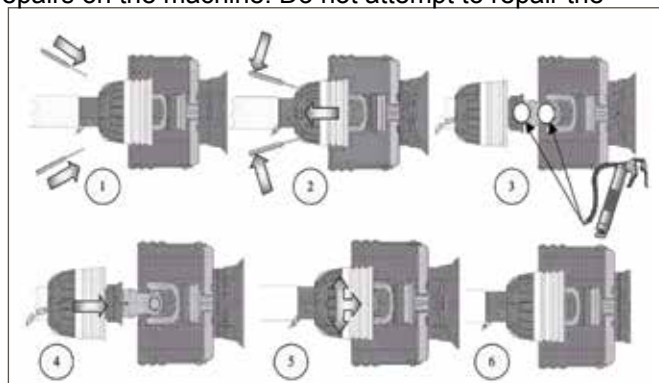

PTO Guard Greasing Intervals

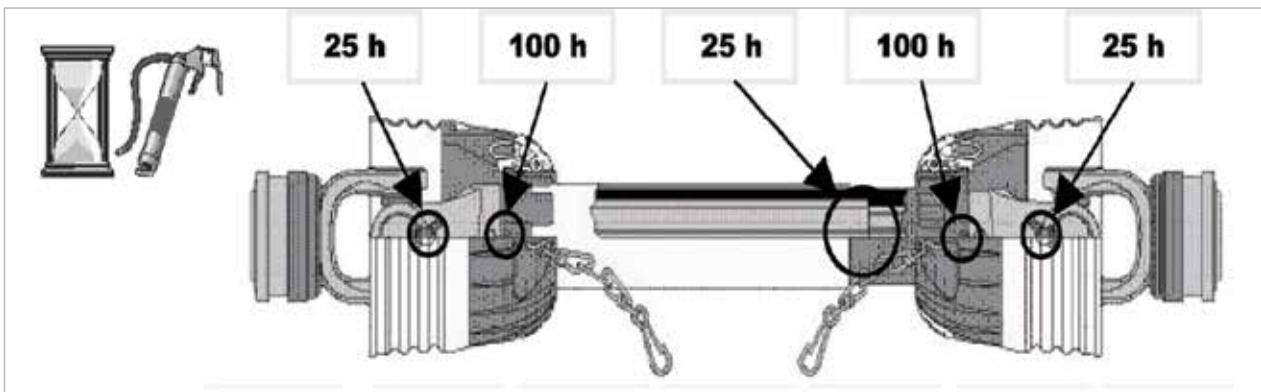

Belt Adjustment

Check belt tension routinely. Remove cover by slackening the retaining bolts. Measure the belt deflection. If the deflection is more than 12mm then adjust

- Slacken the Idler Mounting Bolt.
- Tighten the belt using the tensioner
- Tension until deflection is 12mm



When the drive has been operating under load for a short period (2 to 3 hours) check and ensure that the belts remain at the appropriate tension.

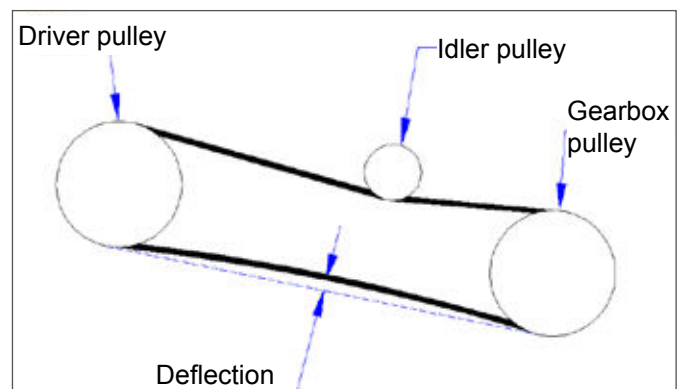
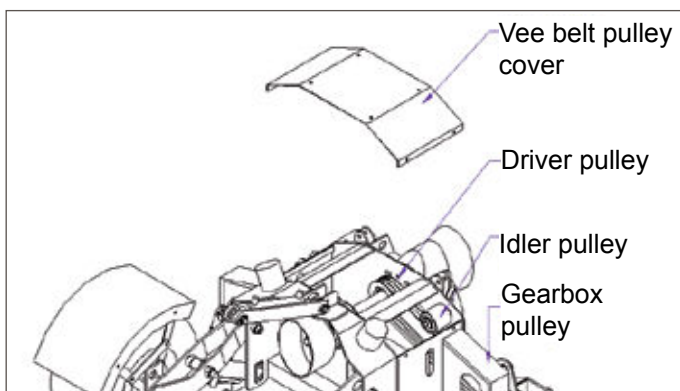

Belt Removal & Fitting

Check belt tension routinely.

- Remove cover by slackening the retaining bolts
- Loosen Idler Rollers
- Slacken Bolts on front bearing
- Slacken Grub Screws on front & rear bearing
- Remove 6 shaft coupling bolts
- Slide split shaft forward to remove belts & add new ones
- Replace Shaft & tighten coupling bolts
- Tighten bolts on Bearing
- Tighten Grub Screw on front & rear bearings
- Tension Belt
- Tighten Idler Rollers
- Replace Top Cover

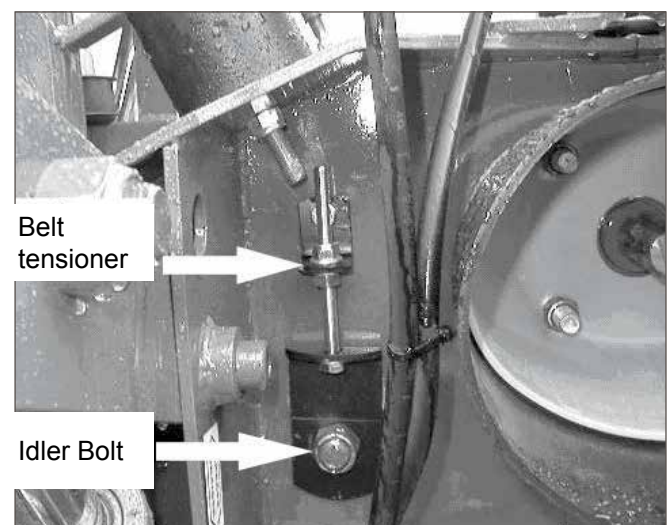

Wheel nuts

Wheel nuts should be torqued to 240Nm. Do not overtighten nuts as damage can occur.

Taper Bush Installation

1. Clean & degrease the bore and taper surfaces of the bush and the tapered bore of the pulley. Insert the bush and the tapered bore of the pulley. Insert the bush in the pulley hub and line up the holes (half thread holes must line up with half straight holes).
2. Lightly oil the grub screws and screw them in, do NOT tighten yet.
3. Clean & degrease the shaft. Fit pulley with taper bush on shaft & locate in desired position.
4. When using a key it should first be fitted in the shaft keyway.

NOTE: There must be a top clearance between the key and the keyway in the bore

5. Using a Hexagon wrench, gradually tighten the grub screws to 48 Nm.

When the drive has been operating under load for a short period (half to 1 hour) check and ensure that the screws remain at the appropriate tightening torque.

6. In order to eliminate the ingress of dirt, fill all empty holes with grease.

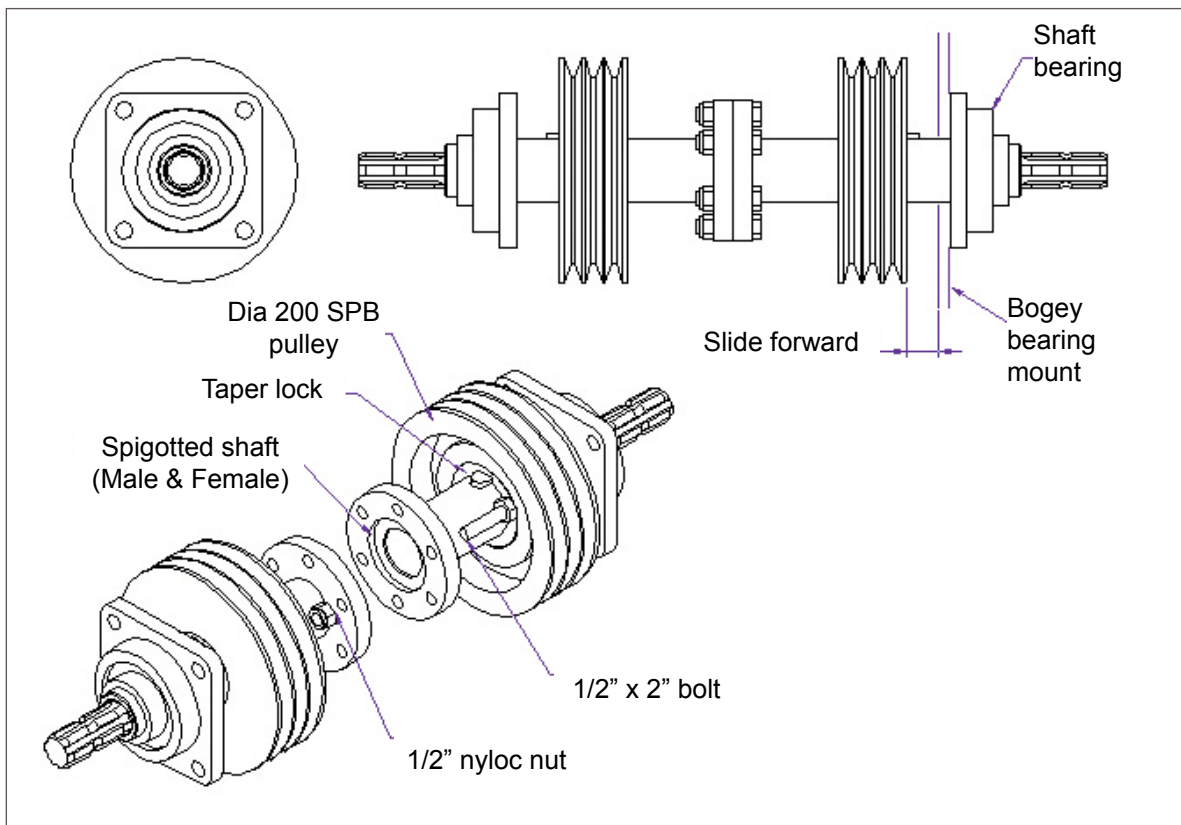

Taper Bush Removal

1. Slacken & remove the screws, after oiling, point and thread into the jacking off hole in the bush
2. Tighten screw until the bush is loose in the hub and pulley is free on the shaft
3. Remove pulley bush assembly from shaft.

IMPORTANT There must be a top clearance between the key and the keyway in the bush, If the top of the Key interferes with the taper bush then the bush will not tighten correctly & will loosen again over a short period of time.

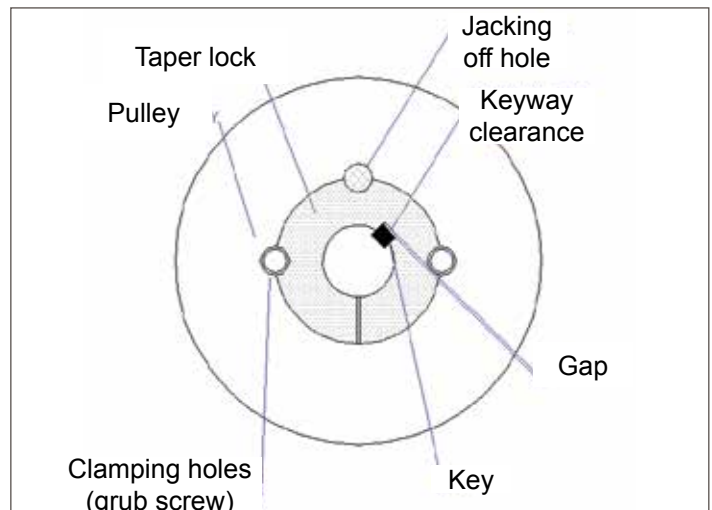

Maintenance Schedule

TDR Rollermower

Grease the following:

	INITIALLY	every 8 HOURS	every 16 HOURS	every 40 HOURS
PTO Shaft Yoke Ends (8)	●		●	
Main drive bearings (2)	●		●	
Wing pivot (6)	●		●	
Drawbar pivot (2)	●			●
Wing arm pivots (4)	●			●
Roller bearings (12)	●			●
Roller height adjusters (12)	●			●
Axle pivot (2)	●			●
Axle (2)	●			●
Rear deck lift arms (2)	●			●
Hydraulic ram pivots (8)	●			●

All nuts and bolts in the transmission including Rubber couplings, Star Drives, PTO Shafts and Gearboxes should be checked for tightened after mowing at the following intervals. Lubricate moveable mechanical joints when required.

1st 50 Acres

1st 100 Acres

1st 250 Acres

And every 250 acres thereafter.

NOTE: ENSURE BLADE ROTATION AND TIMING IS CORRECT AFTER SERVICING TRANSMISSION.

After servicing the machine a competent person must test it and make sure that the machine is safe to use.

Storage and Disposal

At the end of the season or if you are not planning on using the machine for a while, please follow these instructions:

- Wash and dry the machine.
- Do a complete checkover of the machine and, if necessary, change damaged or worn parts. If the paintwork/ galvanising is damaged treat these areas accordingly and repaint.
- Lubricate the not painted parts and all the lubricating points.
- Storing the machine inside will prolong its life and give you better service in the next season.

If you are not planning on using the machine ever again and wish dispose of it, please remove any polluting/harmful substances from the machine (eg. oil, grease etc.) and recycle these in accordance with local laws and regulations.

The machine is mainly made of steel which is widely recyclable.

Trouble Shooting

Fault	Cause	Remedy
Leaves a streak of uncut or partially cut grass	Blades dull or bent	Replace blades
	Carrier RPM too low	Use correct PTO speed
	Field conditions are so wet that the tractor tire is pushing grass into mud	Too wet to mow. Stop operation and wait until it is drier
	Ground speed too fast	Reduce ground speed by shifting to a lower gear
	Grass is down from previous weather conditions	Mow in only one direction
	Possible build-up materials under mower	Clean mower
	Blades mounted incorrectly (cutting edge against direction rotation)	Change blades so that cutting edge is facing correct rotation.
Fault	Cause	Remedy
Material discharges from mower unevenly; bunches of material along with swath	Material too high and too much material	Reduce ground speed but maintain 540rpm at tractor PTO or make two passes over material. Raise mower for the first pass and lower to desired height for the second and cut a 90 degree angle to first pass
	Grass wet	Allow grass to dry before mowing. Slow ground speed of tractor but keep engine running at full PTO rpm. Cutting lower will help
Gearbox overheating	Low on lubricant	Fill to proper level
	Improper type lubricant	Replace with proper lubricant
	Excessive grass / debris build-up around gearbox	Remove grass, etc from machine
Blade is scalping ground	Mower too low	Raise mower-reset wheels
	Field is ridged	Cut field at a different angle
	Field is too wet	Stop and wait until it is dried
Mower will not cut.	Shear bolt sheared	Install new shear bolt
Blades wear too fast	Cutting in sandy conditions	Increase cutting height
	Cutting in rocky conditions	Increase cutting height
	Blades hitting the ground	Increase cutting height
Mower seems to require excessive power	Advancing into grass too rapidly	Reduce forward travel speed
	Hitting ground	Raise mower and reset wheels
	Worn or dull blades	Sharpen or replace blades
	Tractor not large enough	Use larger horsepower tractor

Excessive vibration	Check gearbox bolts	Tighten if loose
	Check for loose nuts on blades	Tighten if loose
	Blade broken	Replace blades, in set
	New blade or bolts matched with worn blade or bolts	Replace blades or bolts in sets
	Drivelines not phased correctly. Implement and tractor yokes must be in line	Phase the driveline. Replace if necessary
Noisy machine	Worn bearing	Replace bearings
	Low oil in gearbox	Check level and add oil
	Loose Parts	Check all bolts are fully tightened
	Wrong PTO rpm rate	Check PTO rate & adjust as necessary
	Rotors bent / broken	Replace bent or missing blades
	Bent PTO shaft	Check PTO shafts are aligned correctly
		Check output shaft on gearboxes are not bent
	Check driveline between gearboxes is aligned.	
Gearbox leaking	Damaged oil seal	Replace seal
	Bent shaft	Replace oil seal and shaft
	Shaft rough in oil seal area	Replace or repair shaft
	Oil seal installed incorrectly	Replace seal
	Oil seal not sealing in the housing	Replace seal or use a sealant on outside diameter of seal
	Oil level too high	Drain oil to proper level
	Hole in gearbox	Replace the gearbox
	Gasket damaged	Replace gasket
	Bolts loose	Tighten bolts
Remote control issues		Please refer to page 7 of this manual

TDR Rear Deck (8400GR)

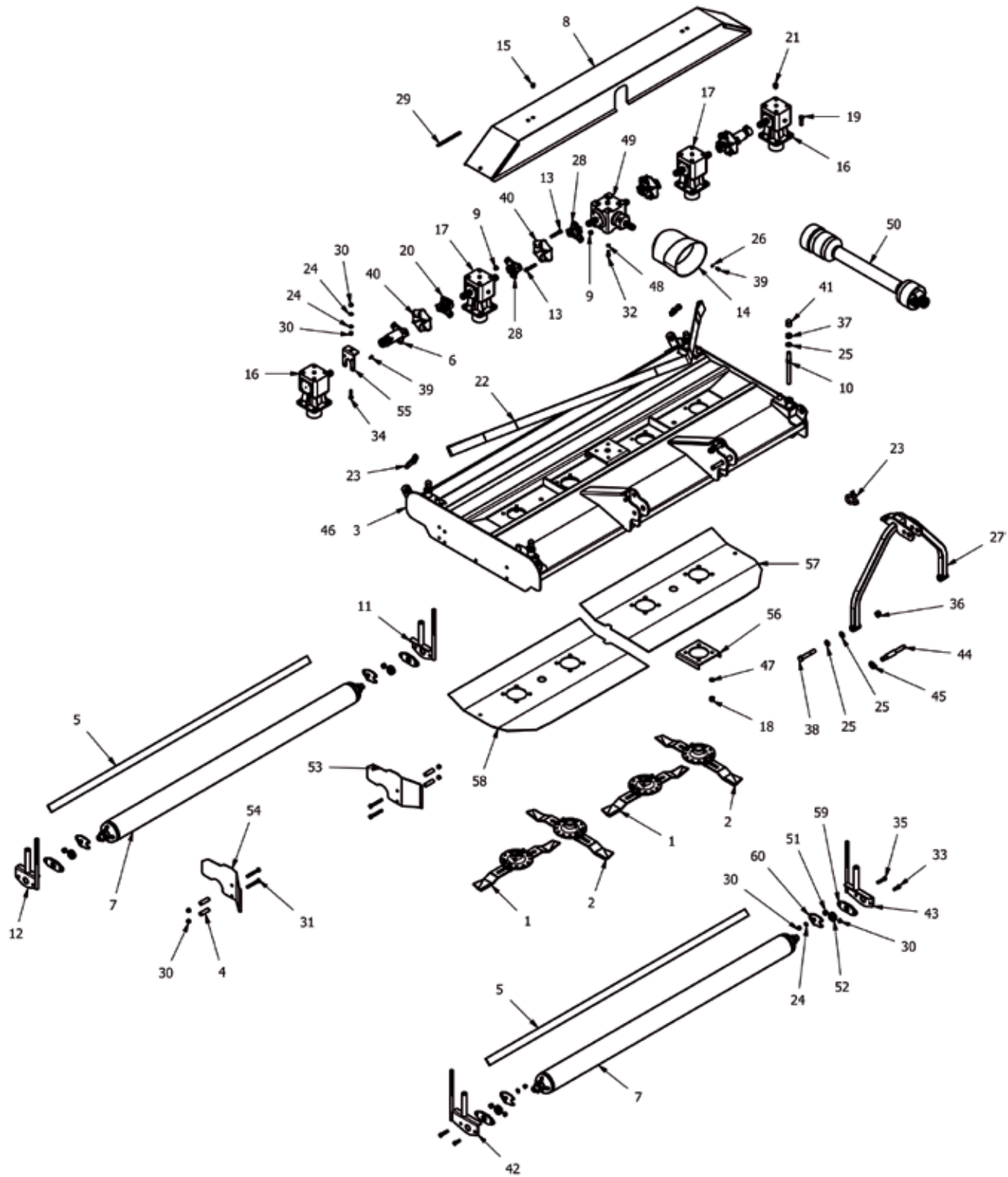

Item	Part No	Description	Qty	Item	Part No	Description	Qty
1	725-FBL	725 FIXED BLADE (Anti_Clk)	2	10	12FTHRAS	THREADED HEIGHT ADJUSTER	4
2	725-FBR	725 FIXED BLADE (Clk)	2	11	12GMRA2L	HEIGHT ADJUSTER (LH)	1
3	84RM-FAB	8400 BODY	1	12	12GMRA2R	HEIGHT ADJUSTER (RH)	1
4	84RM-RDT	DEFLECTOR TUBE	4	13	12x3FSKS	1/2"x3" FINE SOCKET HEAD 12.9	24
5	84RM-SB1	8400 SCRAPER	2	14	190.000.545	PTO GUARD (EXTENDED OVAL)	1
6	GM84-55L	8400 DRIVE TUBE (LONG)	2	15	199099	DIA 15-17mm INSERT	2
7	GM84-ROL	8400 ROLLER	2	16	LF205H	6 SPLINE "L" BOX RATIO 1.92	2
8	GM84/COV	GEARBOX COVER	1	17	LF205TH	6 SPLINE "T" BOX RATIO 1.92	2
9	12F	1/2" FINE NYLOC NUT	24	18	5/8F	5/8" FINE NYLOC NUT	16

TDR Rear Deck (8400GR)

Item	Part No	Description	Qty	Item	Part No	Description	Qty
19	58x2FBZP	5/8"x2" FINE BOLT	16	40	NT55A	RUBBER COUPLING	4
20	60CSD	60mm STAR DRIVE	2	41	RM-M20C	ROLLER ADJUSTER CAP NUT	4
21	8-6-7-00161	3/8" VALVE BREATHER	5	42	RMORA-1	OFFSET HEIGHT ADJUSTER (RH)	1
22	8GMSTRP	8400 RM STRAP (3530mm)	1	43	RMORA-2	OFFSET HEIGHT ADJUSTER (LH)	1
23	EW29A	5/8" "D" SHACKLE	3	44	S15707	CAT 1/2 LINK PIN	2
24	FWM12	M12 FLAT WASHER	8	45	3546	LINCH PIN DIA 9.5	2
25	FWM20	M20 FLAT WASHER	8	46	849	GREASE NIPPLE M6 STR	4
26	FWM8	M8 FLAT WASHER	4	47	SW58	5/8" SPRING WASHER	16
27	GM2	STANDARD A-FRAME	1	48	SWM12	M12 SPRING WASHER	4
28	GM84DRV	6 SPLINE STAR DRIVE	4	49	T27A	6 SPLINE "T" BOX RATIO 1.92	1
29	LS002	ANTI VIBRATION RUBBER	7	50	T500810ENC12RW6	FIXED SLIP CLUTCH 1200 Nm	1
30	M12	M12 NYLOC NUT	16	51	12T-BBS	BLADE BACK SPACER	4
31	M12x100BZP	M12x100 BOLT	4	52	RM-RSN3	SHAFT COLLAR DIA 35	4
32	M12x30SZP	M12x30 SET BOLT	4	53	84RM-RD1	REAR DEFLECTOR	1
33	M12x40BZP	M12x40 BOLT	4	54	84RM-RD1H	REAR DEFLECTOR	1
34	M12x50SZP	M12x50 SET BOLT	2	55	9TGT-CB	GEARBOX COVER BRKT	2
35	M12x60BZP	M12x60 BOLT	4	56	GM6-4F	GEARBOX REINF"	4
36	M20	M20 NYLOC NUT	2	57	GM84-USC	UNDERSIDE COVER	1
37	M20HEX	M20 PLAIN NUT	4	58	GM84-USCH	UNDERSIDE COVER	1
38	M20x120BZP	M20x120 BOLT	2	59	RM-RSN2	ROLLER MOUNT	4
39	M8x16SZP	M8x16 SET BOLT	8	60	RM-RSN4	SCRAPER MOUNT	4

Roller End Assembly

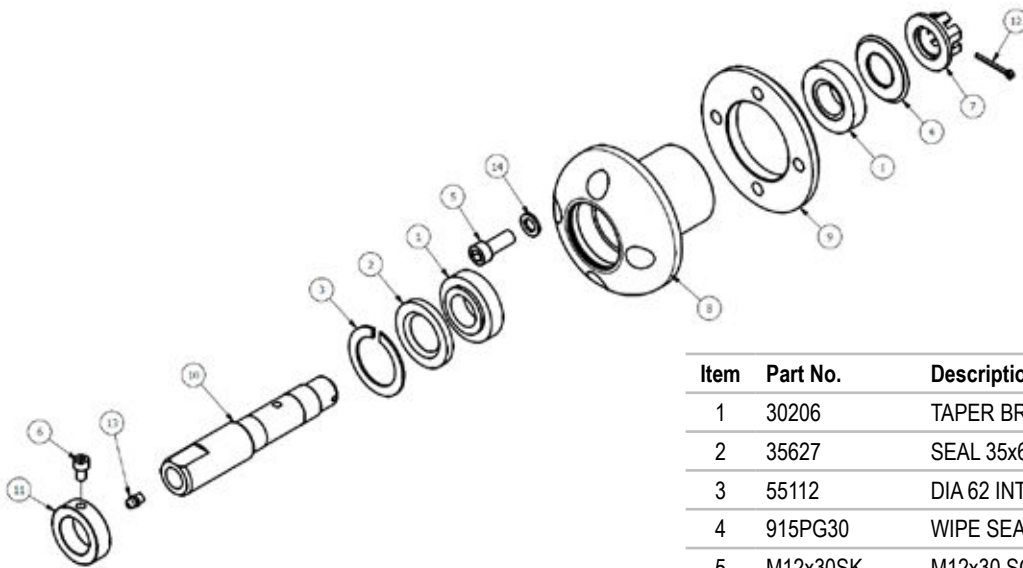

Item	Part No.	Description	Qty
1	30206	TAPER BRG 62x30x17.25	2
2	35627	SEAL 35x62x7	1
3	55112	DIA 62 INT CIRCLIP	1
4	915PG30	WIPE SEAL	1
5	M12x30SK	M12x30 SOCKET HEAD SCREW	4
6	M8x12SK	M8x12mm SOCKET HEAD 12.9	1
7	RM-04NUT	NUT-WASHER WELDMENT	1
8	RM-04REH	ROLLER END HOUSING	1
9	RM-04REP	ROLLER END PLATE	1
10	RM-04RES	ROLLER END SHAFT	1
11	RM-RSN3	SHAFT COLLAR DIA 35	1
12	S1500	SPLIT PIN 1/8"x1 1/2"	1
13	S851	GREASE NIPPLE M8x1.25 STR	1
14	SWM12	M12 SPRING WASHER	4

TDR16000 Wing

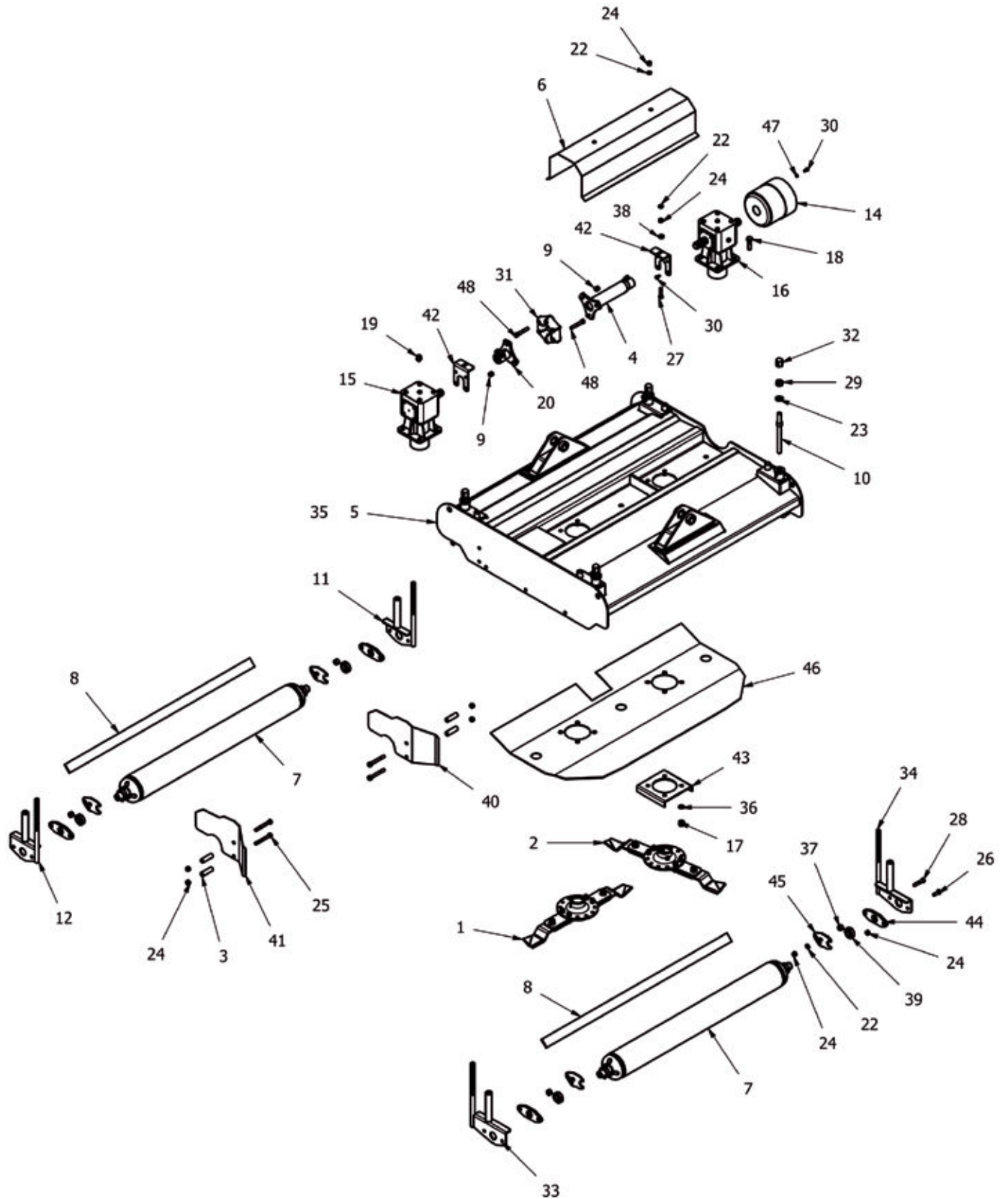

Item	Part No	Description	Qty	Item	Part No	Description	Qty
1	725-SBL	725 SWING BLADE (Anti_Clk)	1	7	TDW-ROL	16ft TDR ROLLER	2
2	725-SBR	725 SWING BLADE (Clk)	1	8	TDW-SB16	16ft SCRAPER	2
3	84RM-RDT	DEFLECTOR TUBE	4	9	12F	1/2" FINE NYLOC NUT	6
4	9GTD	DRIVE TUBE (302mm)	1	10	12F-THRA	THREADED HEIGHT ADJUSTER	4
5	TDW-FAB1	16ft WING (RH)	1	11	12GMRA2L	HEIGHT ADJUSTER (LH)	1
6	TDW-GARD	16ft WING GUARD	1	12	12GMRA2R	HEIGHT ADJUSTER (RH)	1

TDR16000 Wing

Item	Part No	Description	Qty
14	190660-1	GUARD (COVER 660/BASE 661)	1
15	205871	6 SPLINE "L" BOX RATIO 1.47	1
16	205873	6 SPLINE "T" BOX RATIO 1.47	1
17	58F	5/8" FINE NYLOC NUT	8
18	58x214FBZP	5/8"x2 1/4" FINE BOLT	8
19	8-6-7-00161	3/8" VALVE BREATHER	2
20	8SM-18	6 SPLINE STAR DRIVE	1
22	FWM12	M12 FLAT WASHER	8
23	FWM20	M20 FLAT WASHER	4
24	M12	M12 NYLOC NUT	16
25	M12x100BZP	M12x100 BOLT	4
26	M12x35BZP	M12x35 BOLT	4
27	M12x50SZP	M12x50 SET BOLT	2
28	M12x60BZP	M12x60 BOLT	4
29	M20HEX	M20 PLAIN NUT	4
30	M8x16SZP	M8x16 SET BOLT	8
31	NT55A	RUBBER COUPLING	1
32	RM-M20C	ROLLER ADJUSTER CAP NUT	4

Item	Part No	Description	Qty
33	RMORA-1	OFFSET HEIGHT ADJ. (RH)	1
34	RMORA-2	OFFSET HEIGHT ADJUSTER (LH)	1
35	S849	GREASE NIPPLE M6 STR	4
36	SW58	5/8" SPRING WASHER	8
37	12T-BBS	BLADE BACK SPACER	4
38	8SM9-3	BLADE BACK SPACER	2
39	RM-RSN3	SHAFT COLLAR DIA 35	4
40	84RM-RD1	REAR DEFLECTOR	1
41	84RM-RD1H	REAR DEFLECTOR	1
42	9TGT-CB	GEARBOX COVER BRKT	2
43	GM6-4F	GEARBOX REINF"	2
44	RM-RSN2	ROLLER MOUNT	4
45	RM-RSN4	SCRAPER MOUNT	4
46	TDW-USC1	16ft UNDERSIDE COVER	1
47	FWM8	M8 FLAT WASHER	4
48	12x3FSKS	1/2"x3" FINE SOCKET HEAD 12.9	6

Scraper Bar Set Up

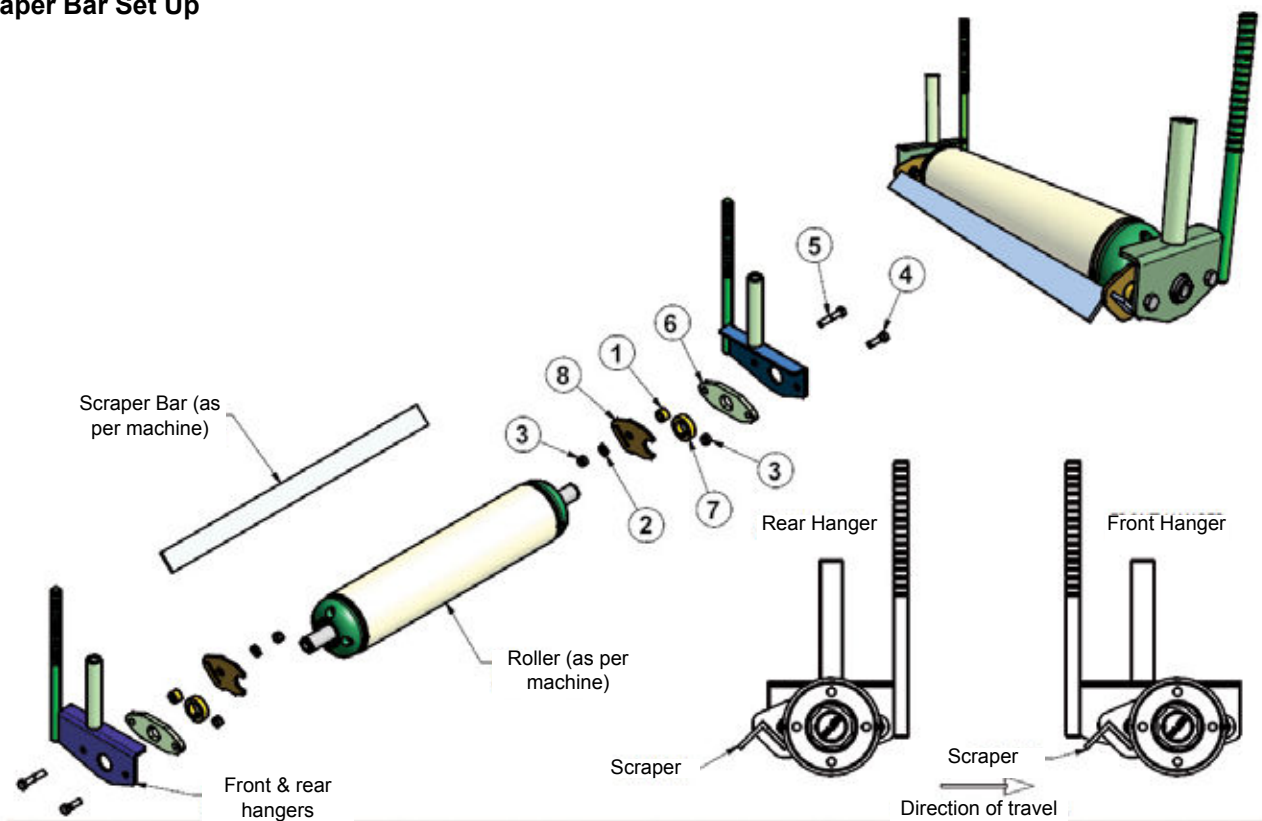

Item	Part No	Description	Qty
1	12T-BBS	BLADE BACK SPACER	2
2	FWM12	M12 FLAT WASHER	2
3	M12	M12 NYLOC NUT	4
4	M12x40BZP	M12x40 BOLT	2
5	M12x60BZP	M12x60 BOLT	2
6	RM-RSN2	ROLLER MOUNT	2
7	RM-RSN3	SHAFT COLLAR DIA 35	2
8	RM-RSN4	SCRAPER MOUNT	2

TDR20000 Wing

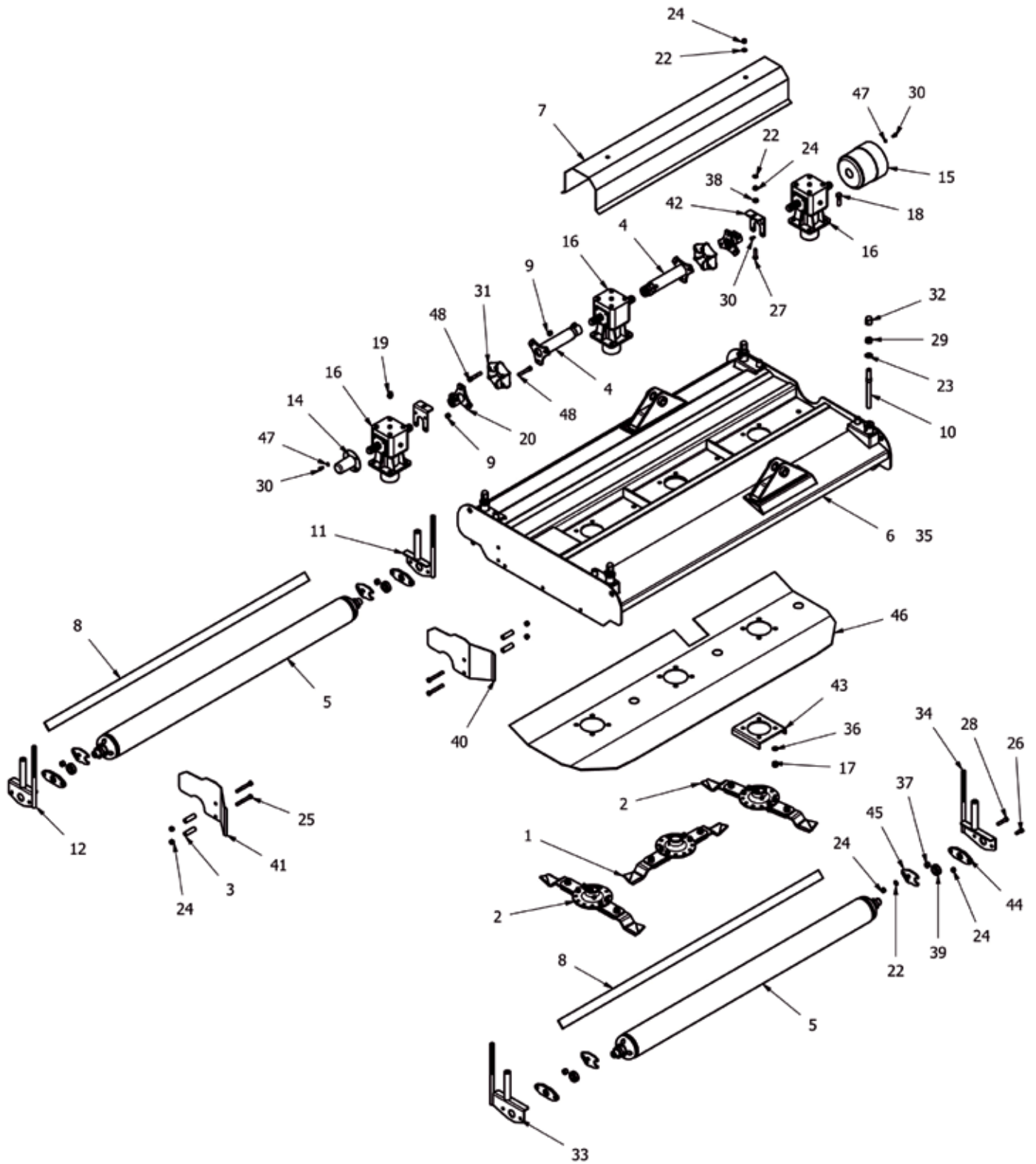

Item	Part No	Description	Qty
1	725-SBL	725 SWING BLADE (Anti_Clk)	1
2	725-SBR	725 SWING BLADE (Clk)	2
3	84RM-RDT	DEFLECTOR TUBE	4
4	9GTD	DRIVE TUBE (302mm)	2
5	TDW-20RL	20ft TDR ROLLER	2
6	TDW-FAB2	20ft WING (RH)	1
7	TDW-GARD2	20ft WING GUARD	1
8	TDW-SB20	20ft SCRAPER	2

Item	Part No	Description	Qty
9	12F	1/2" FINE NYLOC NUT	12
10	12F-THRA	THREADED HEIGHT ADJUSTER	4
11	12GMRA2L	HEIGHT ADJUSTER (LH)	1
12	12GMRA2R	HEIGHT ADJUSTER (RH)	1
14	190592	PTO HAT	1
15	190660-1	GUARD (COVER 660/BASE 661)	1
16	205873	6 SPLINE "T" BOX RATIO 1.47	3
17	58F	5/8" FINE NYLOC NUT	12

TDR20000 Wing

Item	Part No	Description	Qty
18	58x214FBZP	5/8"x2 1/4" FINE BOLT	12
19	8-6-7-00161	3/8" VALVE BREATHER	3
20	8SM-18	6 SPLINE STAR DRIVE	2
22	FWM12	M12 FLAT WASHER	8
23	FWM20	M20 FLAT WASHER	4
24	M12	M12 NYLOC NUT	16
25	M12x100BZP	M12x100 BOLT	4
26	M12x35BZP	M12x35 BOLT	4
27	M12x50SZP	M12x50 SET BOLT	2
28	M12x60BZP	M12x60 BOLT	4
29	M20HEX	M20 PLAIN NUT	4
30	M8x16SZP	M8x16 SET BOLT	10
31	NT55A	RUBBER COUPLING	2
32	RM-M20C	ROLLER ADJUSTER CAP NUT	4
33	RMORA-1	HEIGHT ADJUSTER (RH)	1

Item	Part No	Description	Qty
34	RMORA-2	HEIGHT ADJUSTER (LH)	1
35	S849	GREASE NIPPLE M6 STR	4
36	SW58	5/8" SPRING WASHER	12
37	12T-BBS	BLADE BACK SPACER	4
38	8SM9-3	BLADE BACK SPACER	2
39	RM-RSN3	SHAFT COLLAR DIA 35	4
40	84RM-RD1	REAR DEFLECTOR	1
41	84RM-RD1H	REAR DEFLECTOR	1
42	9TGT-CB	GEARBOX COVER BRKT	2
43	GM6-4F	GEARBOX REINF"	3
44	RM-RSN2	ROLLER MOUNT	4
45	RM-RSN4	SCRAPER MOUNT	4
46	TDW-USC2	20ft UNDERSIDE COVER	1
47	FWM8	M8 FLAT WASHER	6
48	12x3FSKS	1/2"x3" SOCKET HEAD 12.9	12

Axles

TDR16000 Axle

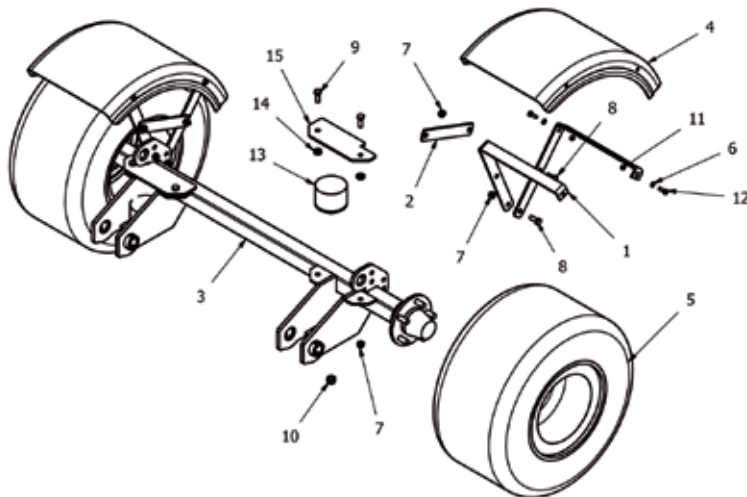

Item	Part No	Description	Qty
1	TD-MGD1	MUDGUARD MOUNT	4
2	TD-MGD3	MUDGUARD TIE	2
3	TDA-1601	16ft AXLE	1
4	TDA-MGRD	WHEEL MUDGUARD	2
5	26120012	DIA 650x320mm	2
6	FWM8	M8 FLAT WASHER	8
7	M12	M12 NYLOC NUT	12
8	M12x30SZP	M12x30 SET BOLT	8
9	M12x35BZP	M12x35 BOLT	4
10	M16	M16 NYLOC NUT	2
11	M8	M8 NYLOC NUT	8
12	M8x25BZP	M8x25 BOLT	8
13	MOT75	DIA 105x75 BUFFER	2
14	8SM9-3	BLADE BACK SPACER	4
15	TDA-AP6	AXLE CAP	2

TDR20000 Axle

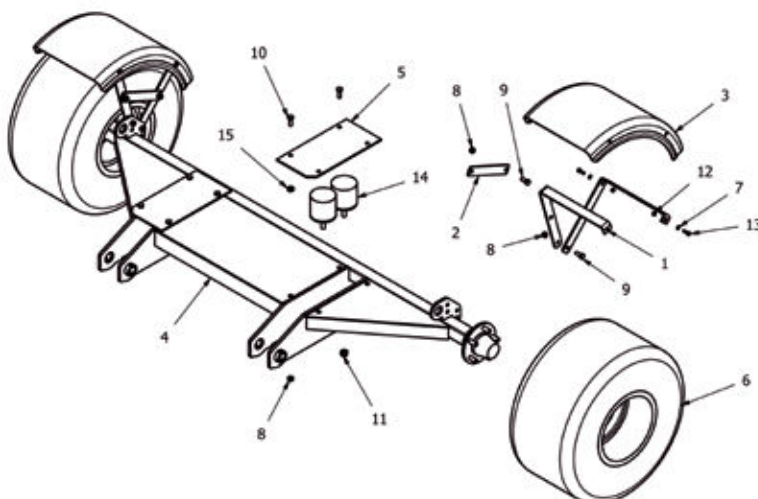

Item	Part No	Description	Qty
1	TD-MGD1	MUDGUARD MOUNT	4
2	TD-MGD3	MUDGUARD TIE	2
3	TDA-MGRD	WHEEL MUDGUARD	2
4	TDA20N01	20ft AXLE	1
5	TDA20N10	BUFFER COVER	2
6	3605512	DIA 695x345mm	2
7	FWM8	M8 FLAT WASHER	8
8	M12	M12 NYLOC NUT	16
9	M12x30SZP	M12x30 SET BOLT	8
10	M12x35BZP	M12x35 BOLT	8
11	M16	M16 NYLOC NUT	4
12	M8	M8 NYLOC NUT	8
13	M8x25BZP	M8x25 BOLT	8
14	MOT10	DIA 105x100 BUFFER	4
15	8SM9-3	BLADE BACK SPACER	8

TDR Braked Axle Option

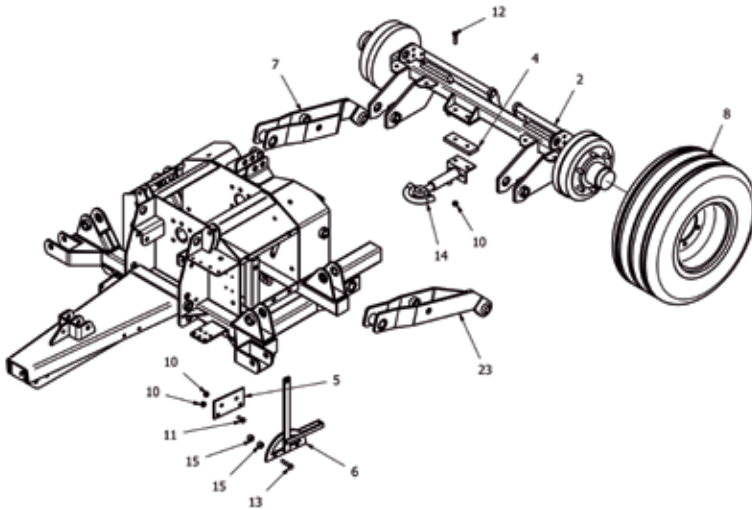

Item	Part No	Description	Qty
2	TDA-167001	16ft BRAKED AXLE	1
3	TDA-167003	CHAIN LINK MOUNT	2
4	TDA-167006	BRAKE RAM SPACER	1
5	TDA-167008	BRAKE MOUNT	1
6	TDA-167009	HAND BRAKE	1
7	TDA-167050	16ft (BRAKED) REAR ARM (RH)	1
8	30115145	DIA 720x275mm	2
9	CL12-1	1/2" CHAIN LINK	3
10	M12	M12 NYLOC NUT	6
11	M12x30SZP	M12x30 SET BOLT	2
12	M12x50BZP	M12x50 BOLT	2
13	M12x60BZP	M12x60 BOLT	2
14	QV70	STD TANKER BRAKE RAM	1
15	12T-BBS	BLADE BACK SPACER	4
23	TDA-167050-H	16ft (BRAKED) REAR ARM (LH)	1

TDR Wing Pivot Assembly

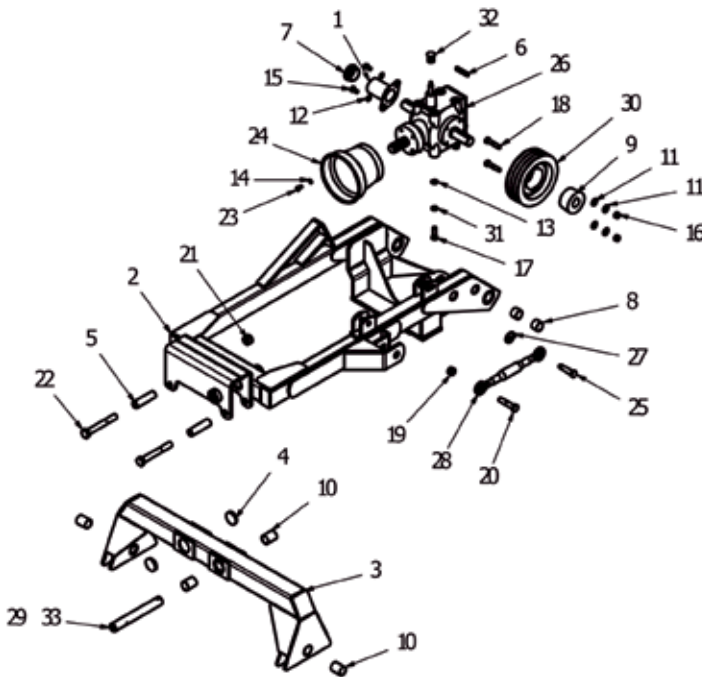

Item	Part No	Description	Qty
1	TDC-PTO1	PTO HAT	1
2	TDP-FAB1	WING PIVOT ARM (RH)	1
3	TDP-FAB2	WING PIVOT BEAM	1
4	TDP-GA1B	NYLON SPACER	2
5	TDP-GA1C	BOLT SPACER	2
6	10x08x65	10x8 PARALLEL KEY	1
7	111070	DIA 50.5-54mm INSERT	1
8	20DX16	DIA 1 1/4" BUSHx1"	4
9	2517-35	2517 35mm BORE	1
10	8SM14	DIA 1 1/4" BUSHx1 3/4"	4
11	D281215	DISC SPRING 28x12x1.5	4
12	FWM10	M10 FLAT WASHER	2
13	FWM12	M12 FLAT WASHER	4
14	FWM8	M8 FLAT WASHER	4
15	M10x20SZP	M10x20 SET BOLT	2
16	M12	M12 NYLOC NUT	2
17	M12x40BZP	M12x40 BOLT	4
18	M12x60BZP	M12x60 BOLT	2

Item	Part No	Description	Qty
19	M16	M16 NYLOC NUT	1
20	M16x75BZP	M16x75 BOLT	1
21	M20	M20 NYLOC NUT	2
22	M20x150BZP	M20x150 BOLT	2
23	M8x16SZP	M8x16 SET BOLT	4
24	NT20A	PTO GUARD (RND)	1
25	S15010	CAT 0 PIN DIA 16x54mm	1
26	S2061258076	SELECT "T" BOX RATIO 2.58	1

Item	Part No	Description	Qty
27	S37	LINCH PIN DIA 6	1
28	S4418-A	CAT 0 TOP LINK	1
29	S849	GREASE NIPPLE M6 STR	1
30	SPB-200C	SPB 200 TRIPLEX PULLEY	1
31	SWM12	M12 SPRING WASHER	4
32	TDKP-31	WAIST KNOB	1
33	TDP-GA1A	PIVOT PIN (250)	1

TDR Drive Shaft Assembly

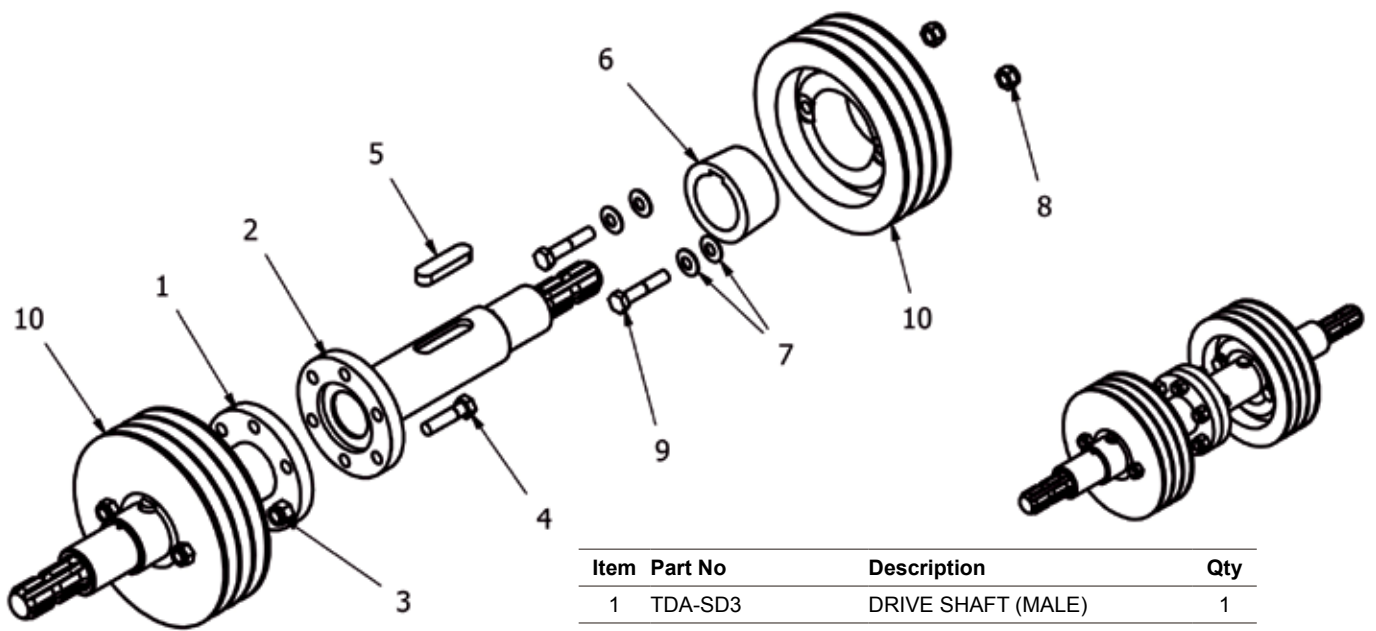

Item	Part No	Description	Qty
1	TDA-SD3	DRIVE SHAFT (MALE)	1
2	TDA-SD7	DRIVE SHAFT (FEMALE)	1
3	12F	1/2" FINE NYLOC NUT	6
4	12x2FBZP	1/2"x2" FINE BOLT	6
5	18x11x70	18x11 PARALLEL KEY	2
6	2517-60	2517 60mm BORE	2
7	D281215	DISC SPRING 28x12x1.5	8
8	M12	M12 NYLOC NUT	4
9	M12x60BZP	M12x60 BOLT	4
10	SPB-200C	SPB 200 TRIPLEX PULLEY	2

TDR Bogey Assembly

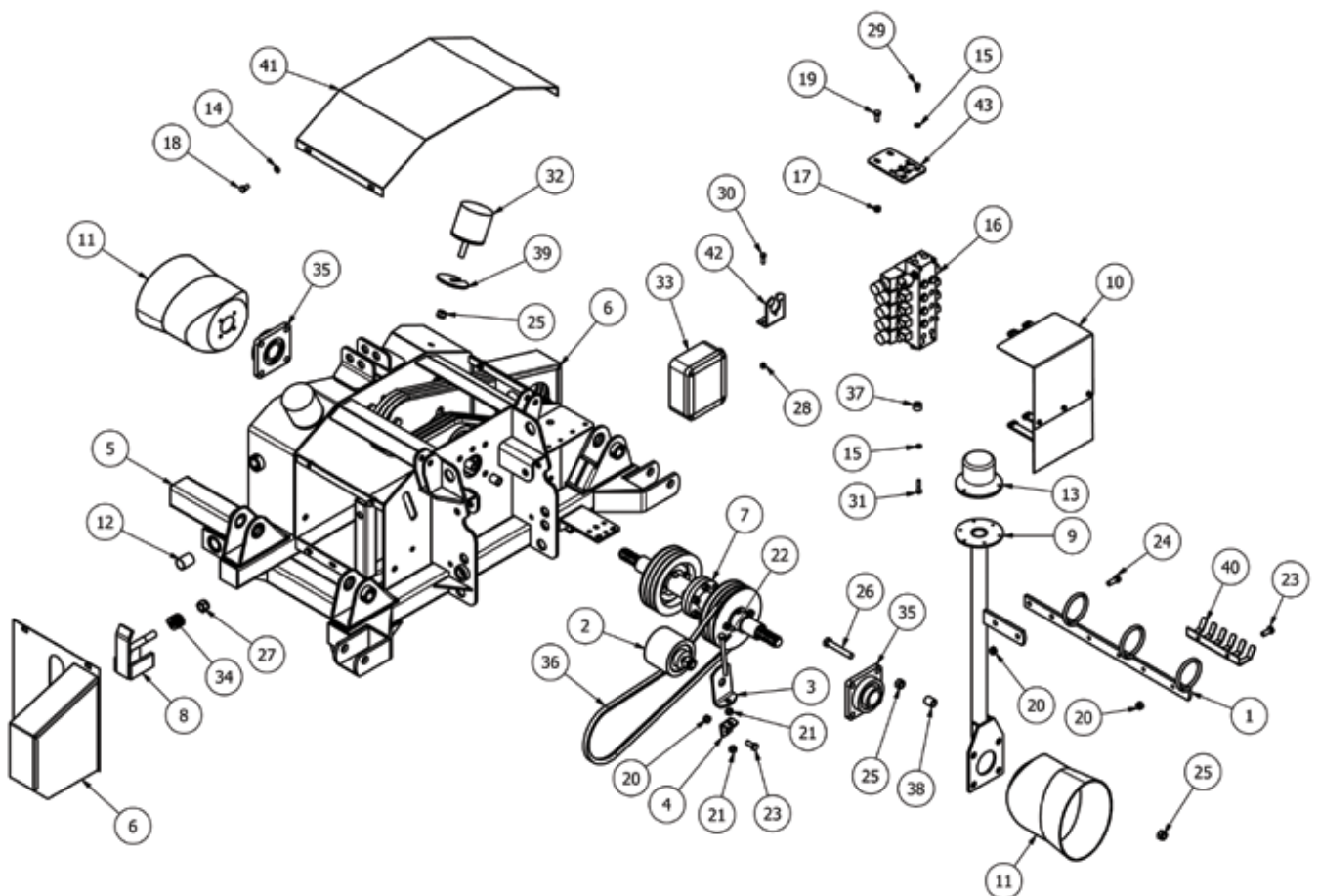

TDR Bogey Assembly

Item	Part No	Description	Qty
1	2TKBC-2	CABLE LOCATION BAR	1
2	TD-ID101	IDLER ROLL ASSEMBLY	2
3	TD-ID201	IDLER ADJUSTER	2
4	TD-ID202	IDLER ANCHOR	2
5	TDA-FAB1	TDR BOGEY FAB	1
6	TDA-GARD	PULLEY GUARD	2
7	TDA-SDGA	DRIVE SHAFT ASSEMBLY	1
8	TDA-SPAJ	STRIKE PLATE ADJUSTER	2
9	TDC-LIT10	TDR BEACON STAND	1
10	TRI-HYD-CV-GA	VALVE COVER ASSY	1
11	190.000.545	PTO GUARD (EXTENDED OVAL)	2
12	8SM14	DIA 1 1/4" BUSHx1 3/4"	4
13	DA49800101	LED BEACON	1
14	FWM10	M10 FLAT WASHER	8
15	FWM8	M8 FLAT WASHER	6
16	GCVB5-2	VICKERS 5 BLOCK ver 2	1
17	M10	M10 NYLOC NUT	6
18	M10x20SZP	M10x20 SET BOLT	8
19	M10x25SZP	M10x25 SET BOLT	2
20	M12	M12 NYLOC NUT	6
21	M12HEX	M12 PLAIN NUT	4
22	M12x150SZP	M12x150 SET BOLT	2

Item	Part No	Description	Qty
23	M12x30SZP	M12x30 SET BOLT	4
24	M12x35BZP	M12x35 BOLT	2
25	M16	M16 NYLOC NUT	18
26	M16x100SZP	M16x100 SET BOLT	8
27	M20	M20 NYLOC NUT	2
28	M8	M8 NYLOC NUT	2
29	M8x16SZP	M8x16 SET BOLT	3
30	M8x25BZP	M8x25 BOLT	2
31	M8x40BZP	M8x40 BOLT	3
32	MOT10	DIA 105x100 BUFFER	2
33	RC-TDR-BASE	REMOTE CONTROL BOX	1
34	TDA-SPS	STRIKE PLATE SPRING	2
35	UCF210 (MSF50)	DIA 50mm FLANGE BRG	2
36	XPB1800	XPB BELT x1800mm	6
37	12T-BBS	BLADE BACK SPACER	3
38	84RM-SBOB	OVERLAP BLADE BUSH	8
39	8T19	BUFFER SPACER	2
40	TA-HCM04	CABLE MOUNT	1
41	TDA-AGRD	BOGEY TOP COVER	1
42	TDH-MP2	HYD PLUG MOUNT	1
43	TDH-MP3	VALVE TOP (VICKERS)	1

TDR Drawbar Assembly

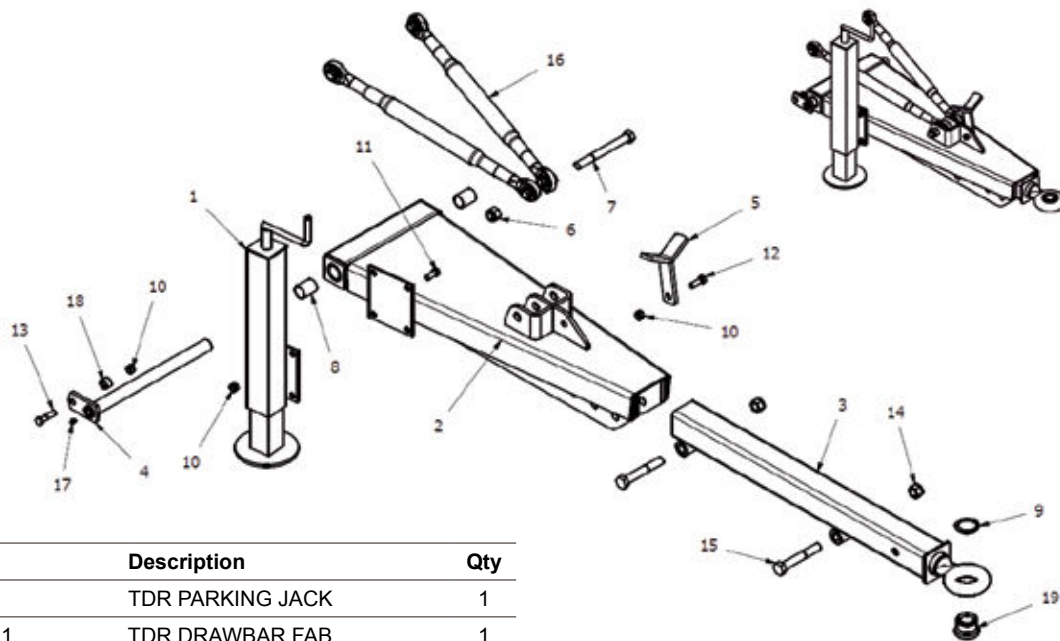

Item	Part No	Description	Qty
1	12GMJK	TDR PARKING JACK	1
2	TDD-FAB1	TDR DRAWBAR FAB	1
3	TDD-HTE	DRAWBAR HITCH EYE	1
4	TDD-PIN	DRAWBAR PIVOT PIN	1
5	TDD-SS	TDR PTO STAND	1
6	34F	3/4" FINE NYLOC NUT	1
7	34x7FBZP	3/4"x7" FINE BOLT	1
8	8SM14	DIA 1 1/4" BUSHx1 3/4"	2
9	AGC2	DIA 50 EXT HEAVY CIRCLIP	1
10	M12	M12 NYLOC NUT	6
11	M12x30SZP	M12x30 SET BOLT	4

Item	Part No	Description	Qty
12	M12x35BZP	M12x35 BOLT	1
13	M12x50BZP	M12x50 BOLT	1
14	M20	M20 NYLOC NUT	2
15	M20x130BZP	M20x130 BOLT	2
16	S300-A	CAT 1-1 TOP LINK	2
17	S849	GREASE NIPPLE M6 STR	2
18	12T-BBS	BLADE BACK SPACER	1
19	TDD-TEB	TOE EYE BUSH	1

Hose Assemblies

Supply & Return Hose Assembly

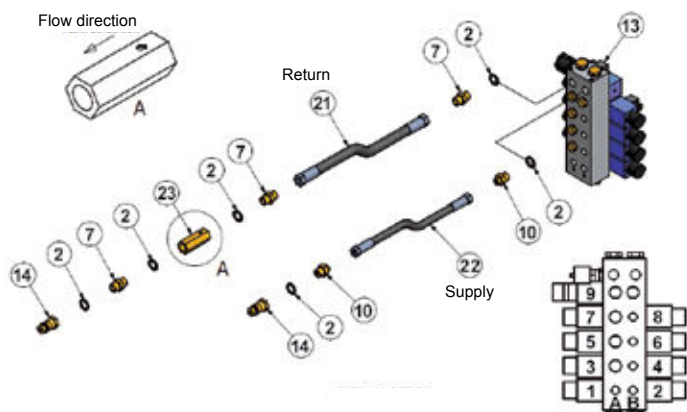

Top Link Hose Assembly

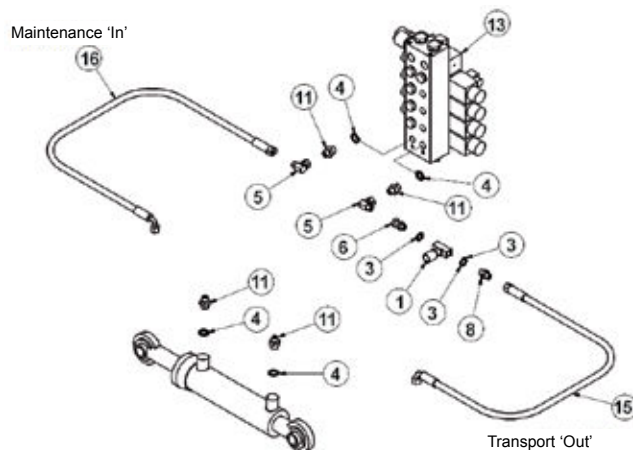

Wing Ram Hose Assembly

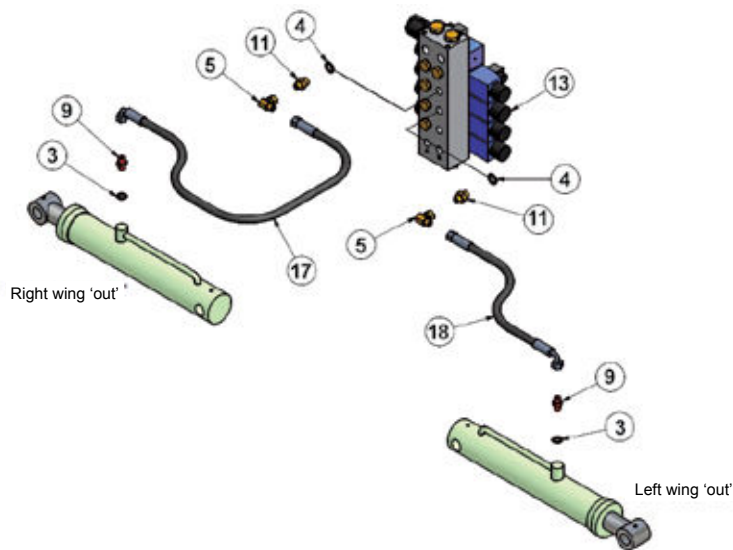

Item	Part No	Description	Qty
1	201011	1/4" 1251 NEEDLE VALVE (BLUE)	2
2	EDOW12	1/2" DOWTY WASHER	6
3	EDOW14	1/4" DOWTY WASHER	8
4	EDOW38	3/8" DOWTY WASHER	7
5	EFM9014	1/4" F/M ELBOW	5
6	EMF14	1/4" M/F CONNECTOR	2
7	EMM12	1/2" M/M CONNECTOR	3
8	EMM14	1/4" M/M CONNECTOR	4
9	EMM14RV	1/4" M/M RESTRICTOR (DIA 1mm)	2
10	EMM3812	1/2-3/8" M/M CONNECTOR	2
11	EMM3814	3/8-1/4" M/M CONNECTOR	7
12	EMMMT14	1/4" M/M/M CONNECTOR	1
13	GCVB5	VICKERS 5 BLOCK	1
14	QRM12	1/2" QUICK RELEASE MALE	2
15	TDR-HOSE-A	1/4"x1900mm Str to Block 90	1
16	TDR-HOSE-B	1/4"x2130mm Str to Block 90	1
17	TDR-HOSE-C	1/4"x1720mm Str to Block 90	1
18	TDR-HOSE-D	1/4"x1090mm Str to Block 90	1
19	TDR-HOSE-E	1/4"x1220mm Str to Block 90	1
20	TDR-HOSE-F	1/4"x430mm Str to Block 90	2
21	TDR-RETURN	1/2"x2800mm Str to Str	1
22	TDR-SUPPLY	3/8"x2800mm Str to Str	1
23	VUR03C	1/2" CHECK VALVE	1

Rear Deck Ram Hose Assembly

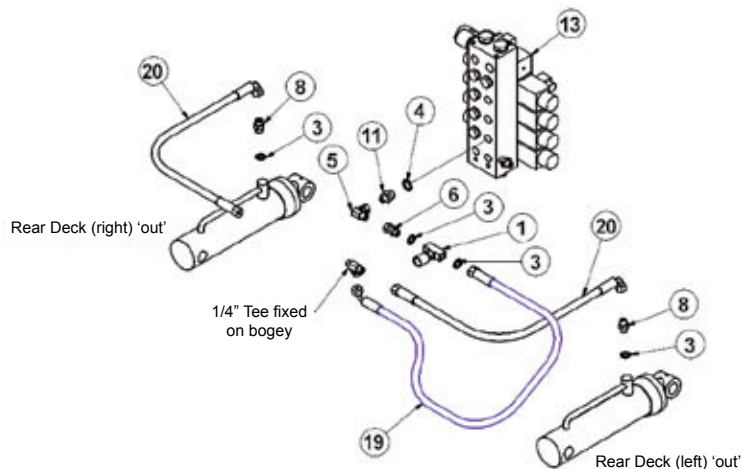

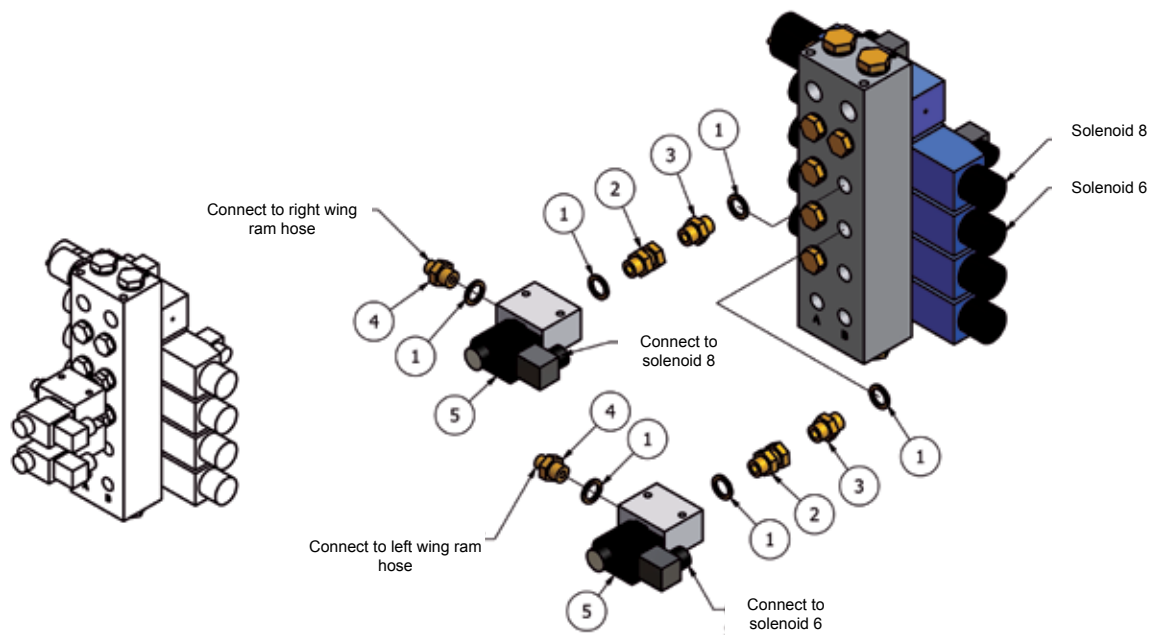

Item	Part No	Description	Qty
1	EDOW38	3/8" DOWTY WASHER	6
2	EMF38	3/8" M/F CONNECTOR	2
3	EMM38	3/8" M/M CONNECTOR	2
4	EMM3814	3/8-1/4" M/M CONNECTOR	2
5	SDC08-2-DG3B-38	Part No. SVP08NC-R001	2

TDR Spring Knob (option)

Item	Part No	Description	Qty
1	DU2012	LIGHT SPRING (SHORT)	1
2	S2061258076	SELECT "T" BOX RATIO 2.58	1
3	TDKP-21	SPRING SEAT	1
4	TDKP-22A	SPRING PLUNGER	1

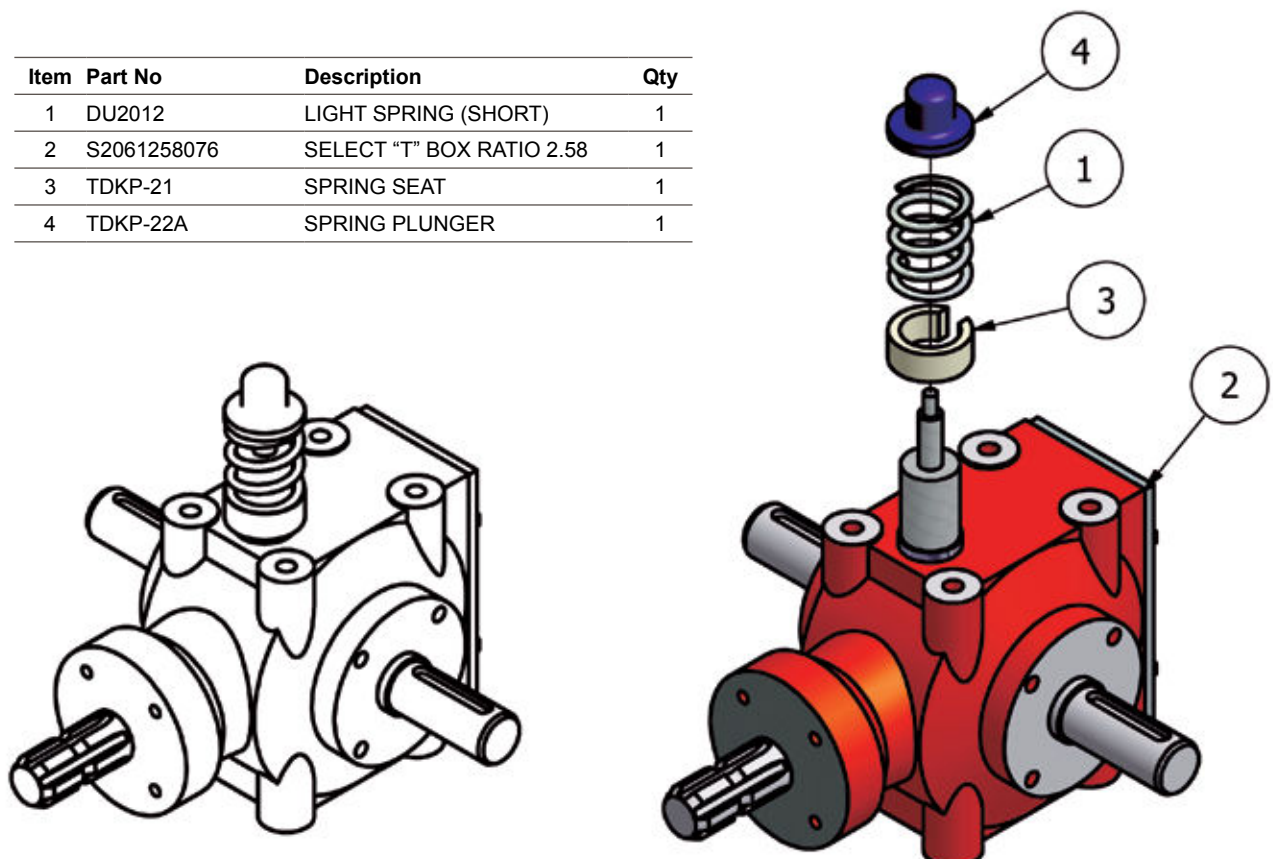

Blades

SWINGING BLADE SYSTEM



Standard system on: TDR Models

MULCHING BLADE SYSTEM

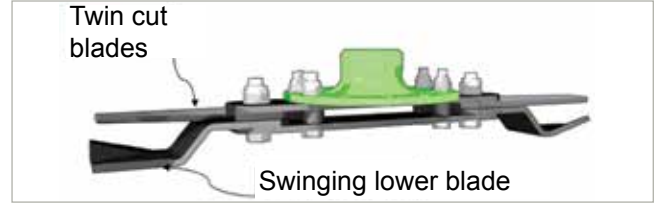

Optional system on: TDR Models

FIXED BLADE SYSTEM

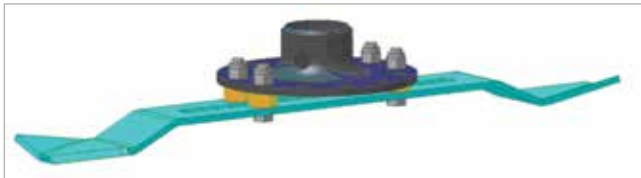

Optional system on: TDR Models

BLADE ROTATIONS

TDR16000 Blade Systems

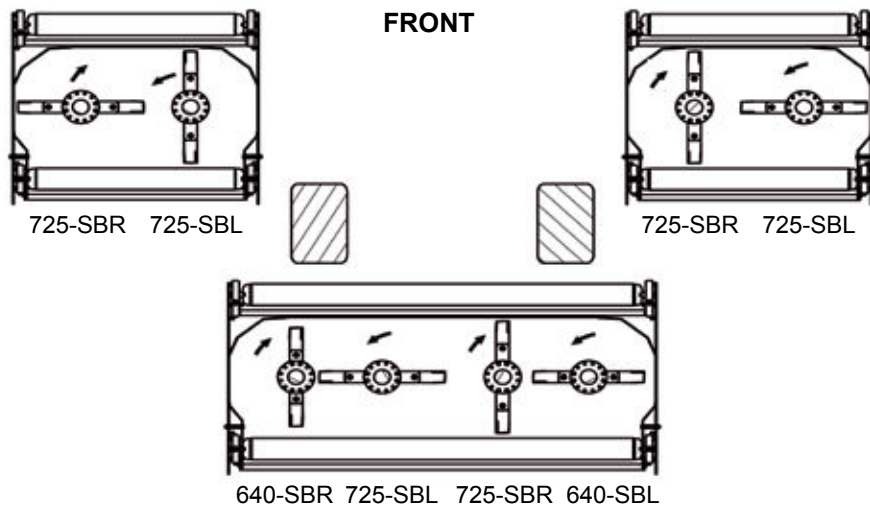

TDR20000 Blade Systems

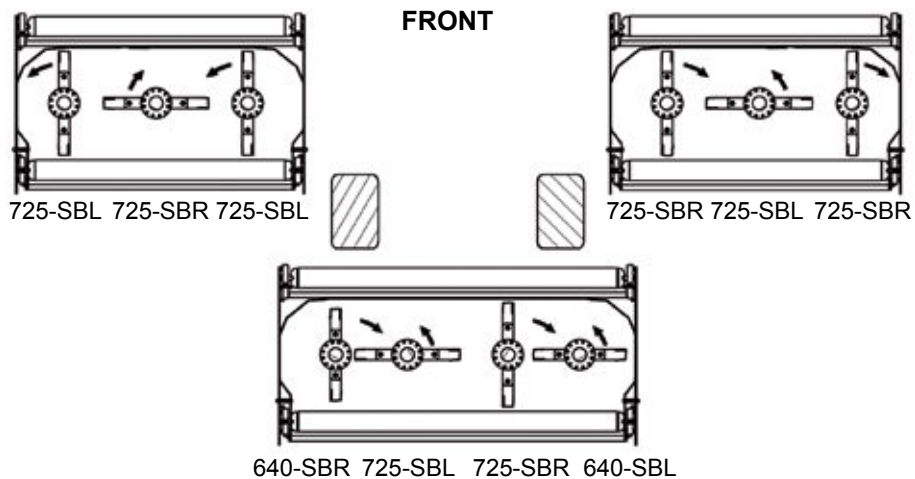

NOTE: Please have the serial number of your machine to hand when ordering blades to ensure you get the correct parts.

SWINGING BLADE SYSTEMS - Standard system on TDR Models

640-SBL - 640 Swing Blade (Anti Clockwise)

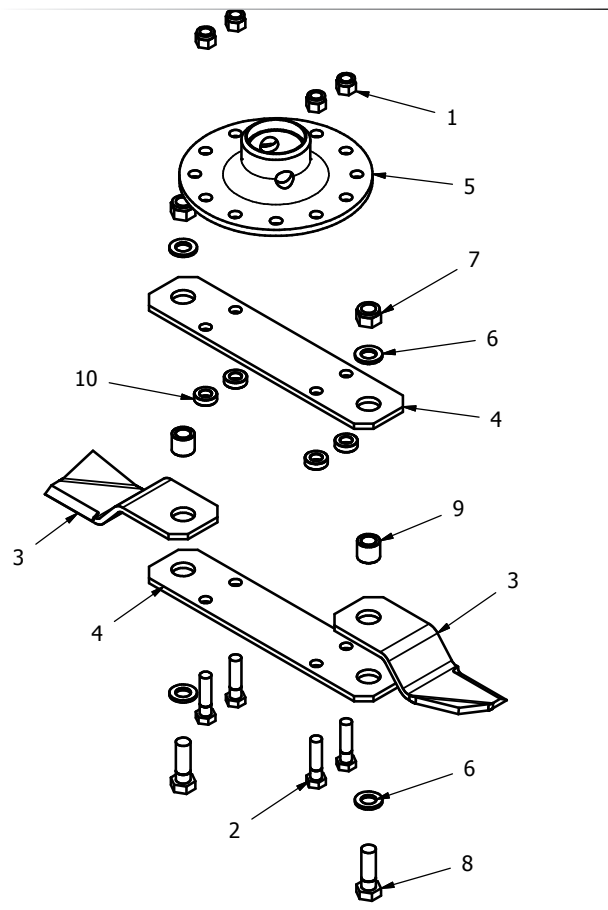

MACHINE	QTY
TDR16000	1
TDR20000	1

Item	Part No	Description	Qty
1	1/2F	1/2" Nyloc Nut	4
2	12x2FBZP	1/2"x2" FINE BOLT	4
3	84RM-SB01	SWING BLADE (Anti-Clk)	2
4	84RM-SBB	BLADE BACK (285 CTR)	2
5	DF-BMP	BLADE MOUNT	1
6	FWM16	M16 FLAT WASHER	4
7	M16	M16 NYLOC NUT	2
8	M16x50BZP	M16x50 BOLT	2
9	84RM-SBBB	BLADE BUSH	2
10	8SM9/3	BLADE BACK SPACER	4

640-SBR - 640 Swing Blade (clockwise)

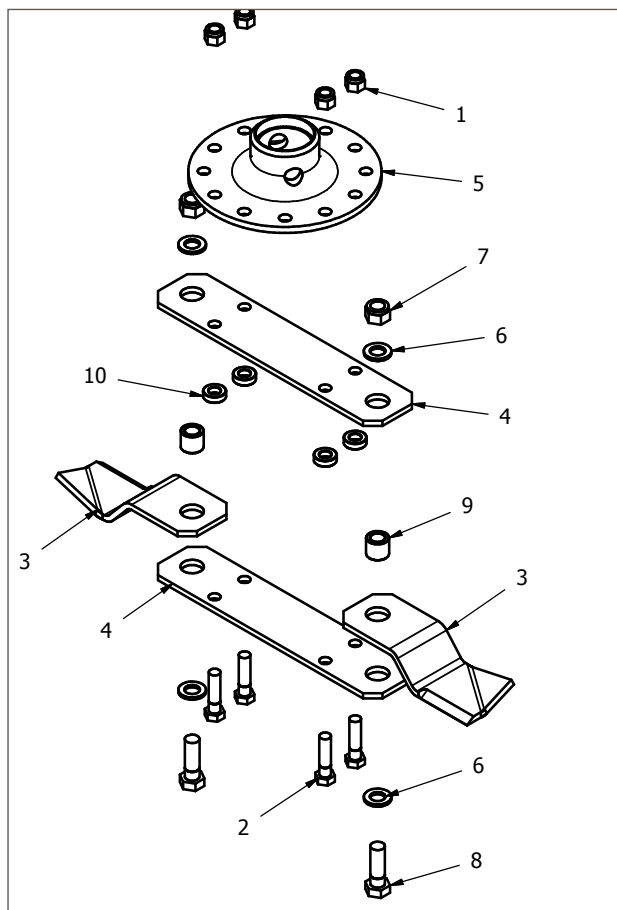

MACHINE	QTY
TDR16000	1
TDR20000	1

Item	Part No	Description	Qty
1	1/2F	1/2" Nyloc Nut	4
2	12x2FBZP	1/2"x2" FINE BOLT	4
3	84RM-SB02	SWING BLADE (Clk)	2
4	84RM-SBB	BLADE BACK (285 CTR)	2
5	DF-BMP	BLADE MOUNT	1
6	FWM16	M16 FLAT WASHER	4
7	M16	M16 NYLOC NUT	2
8	M16x50BZP	M16x50 BOLT	2
9	84RM-SBBB	BLADE BUSH	2
10	8SM9/3	BLADE BACK SPACER	4

725-SBL - 725 Swing Blade (Anti Clockwise)

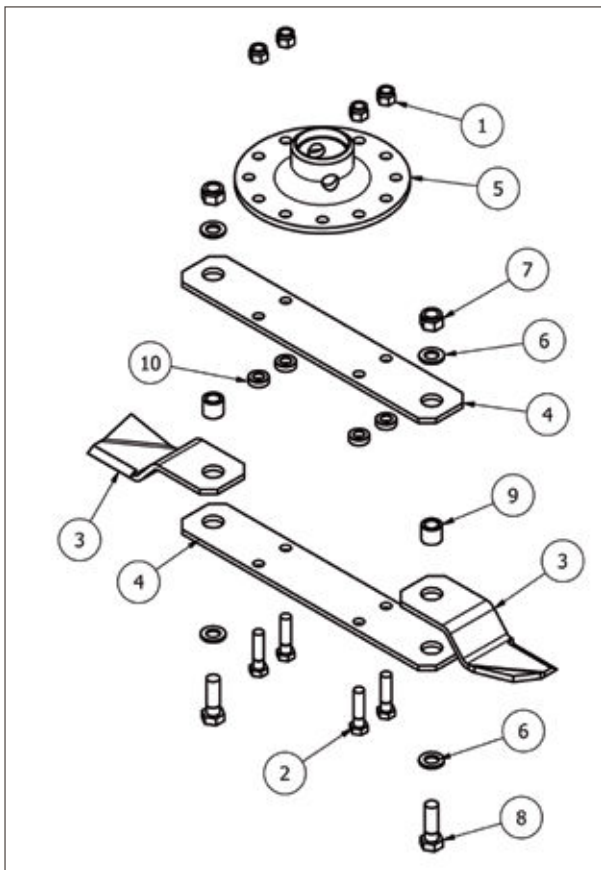

MACHINE	QTY
TDR16000	3
TDR20000	4

Item	Part No	Description	Qty
1	1/2F	1/2" Nyloc Nut	4
2	12x2FBZP	1/2"x2" FINE BOLT	4
3	84RM-SB01	SWING BLADE (A Cik)	2
4	84RM-SBB2	BLADE BACK (370 CTR)	2
5	DF-BMP	BLADE MOUNT	1
6	FWM16	M16 FLAT WASHER	4
7	M16	M16 NYLOC NUT	2
8	M16x50BZP	M16x50 BOLT	2
9	84RM-SBBB	BLADE BUSH	2
10	8SM9/3	BLADE BACK SPACER	4

725-SBR - 725 Swing Blade (Clockwise)

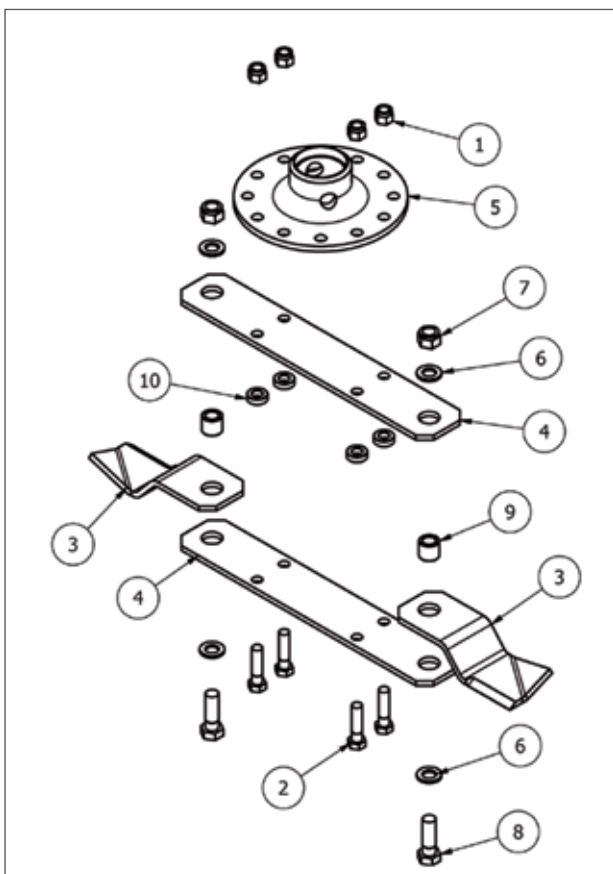

MACHINE	QTY
TDR16000	3
TDR20000	4

Item	Part No	Description	Qty
1	1/2F	1/2" Nyloc Nut	4
2	12x2FBZP	1/2"x2" FINE BOLT	4
3	84RM-SB02	SWING BLADE (Cik)	2
4	84RM-SBB2	BLADE BACK (370 CTR)	2
5	DF-BMP	BLADE MOUNT	1
6	FWM16	M16 FLAT WASHER	4
7	M16	M16 NYLOC NUT	2
8	M16x50BZP	M16x50 BOLT	2
9	84RM-SBBB	BLADE BUSH	2
10	8SM9/3	BLADE BACK SPACER	4

Anti Clockwise Mulching Blade

Clockwise Mulching Blade

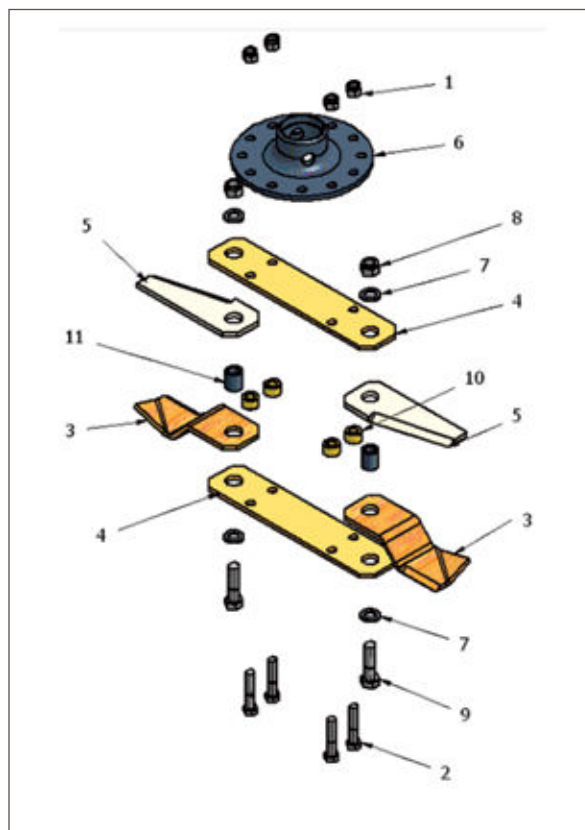
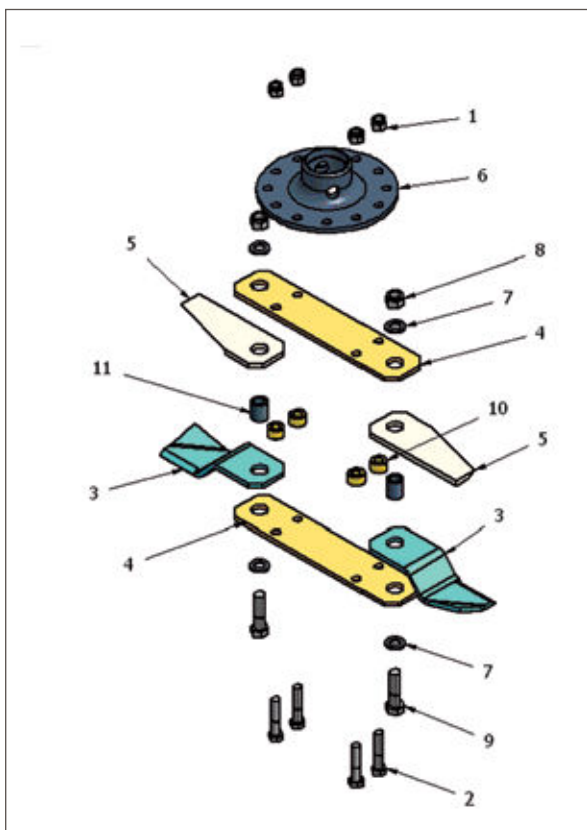

Item	Part No	Description	Qty per rotor
1	1/2F	Nyloc Nut	4
2	12X212FBZP	Bolt	4
3	84RM-SB01	Swing Blade (Anti Clock)	2
	84RM-SB02	Swing Blade (Clock)	2
4	84RM-SBB	Blade Back (285 ctr)	2
	84RM-SBB2	Blade Back (370 ctr)	2
5	84RM-SBOL	Overlap Blade	2
6	DF-BMP	Mounting Plate	1
7	FWM16	Washer	4
8	M16	Nyloc Nut	2
9	M16X60BZP	M16 X 60 Bolts Plated	2
10	12T-BBS	Spacer	4
11	84RM-SBOB	Overlap Bush	2

FIXED BLADE SYSTEMS - Optional system on: 6300, 8400, 11000, 15000 & TDR Models

725 Fixed Blade (Anti Clockwise)

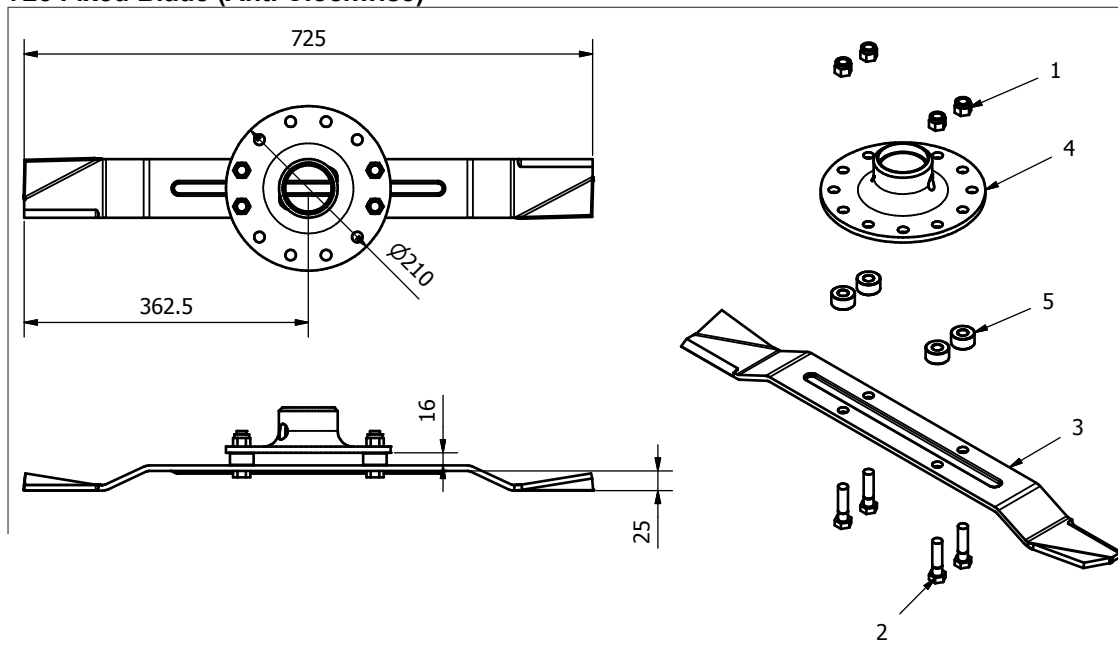

MACHINE	QTY
TDR16000	2 OFF
TDR20000	3 OFF

Item	Part No	Description	Qty
1	12F	1/2" FINE NYLOC NUT	4
2	12x2FBZP	1/2"x2" FINE BOLT	4
3	8FM8-1L	8400 BLADE (Anti-Cik)	1
4	DF-BMP	BLADE MOUNT	1
5	84RM-BSB	BLADE SPACER BUSH	4

725 Fixed Blade (Clockwise)

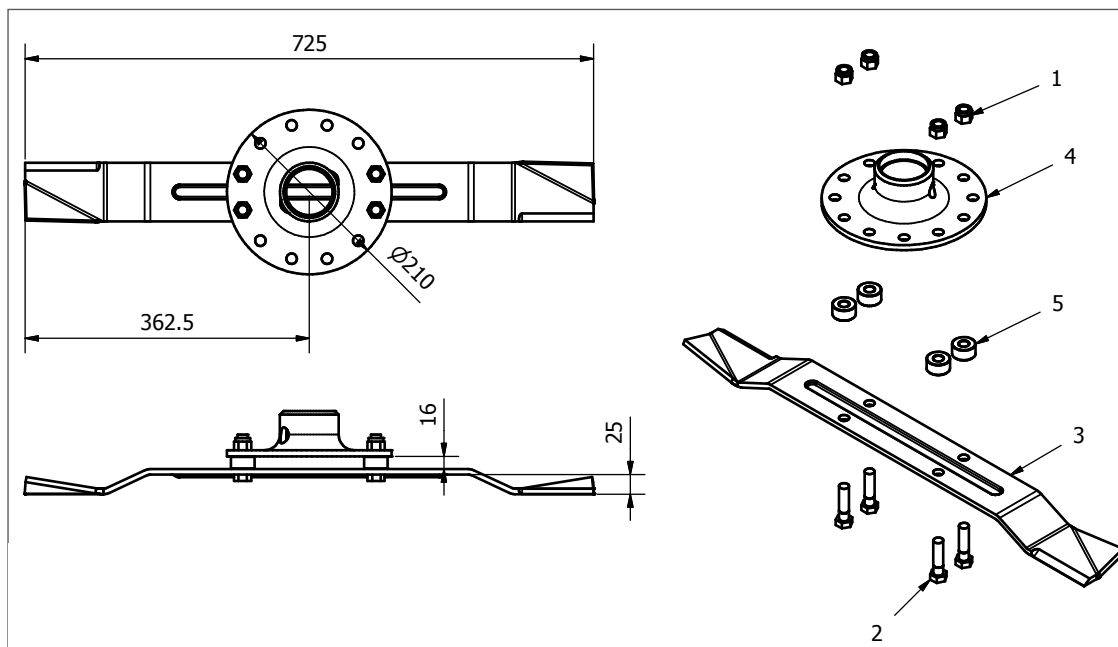

MACHINE	QTY
TDR16000	2 OFF
TDR20000	3 OFF

Item	Part No	Description	Qty
1	12F	1/2" FINE NYLOC NUT	4
2	12x2FBZP	1/2"x2" FINE BOLT	4
3	8FM8-1R	8400 BLADE (Cik)	1
4	DF-BMP	BLADE MOUNT	1
5	84RM-BSB	BLADE SPACER BUSH	4

PTO Shafts

MACHINE	PART NO:	DESCRIPTION:
TDR PRIMARY / 12000 & 18000 R.MOWER	V601210CEC02RW6	V60 SHAFT WIDE ANGLE / SLIP CLUTCH
16000 / 20000 TDR WING	T500350F132132	T50 SHAFT STANDARD
TDR20000 REAR DECK	T501060ENC12RW6	T50 SHAFT SLIP CLUTCH
6000/6300/8000/8400/TDR16000 REAR DECK	T500810ENC12RW6	T50 SHAFT SLIP CLUTCH

Gearboxes

Machine	Gearbox
6000,8000,12000, 12000GR3PTL, TDR16000	LF205
6300, 8400	LF205H
18000, TDR's,	LF205T
6300, 8400	LF205TH
TDR wing	S2061

S2061258076 Gearbox

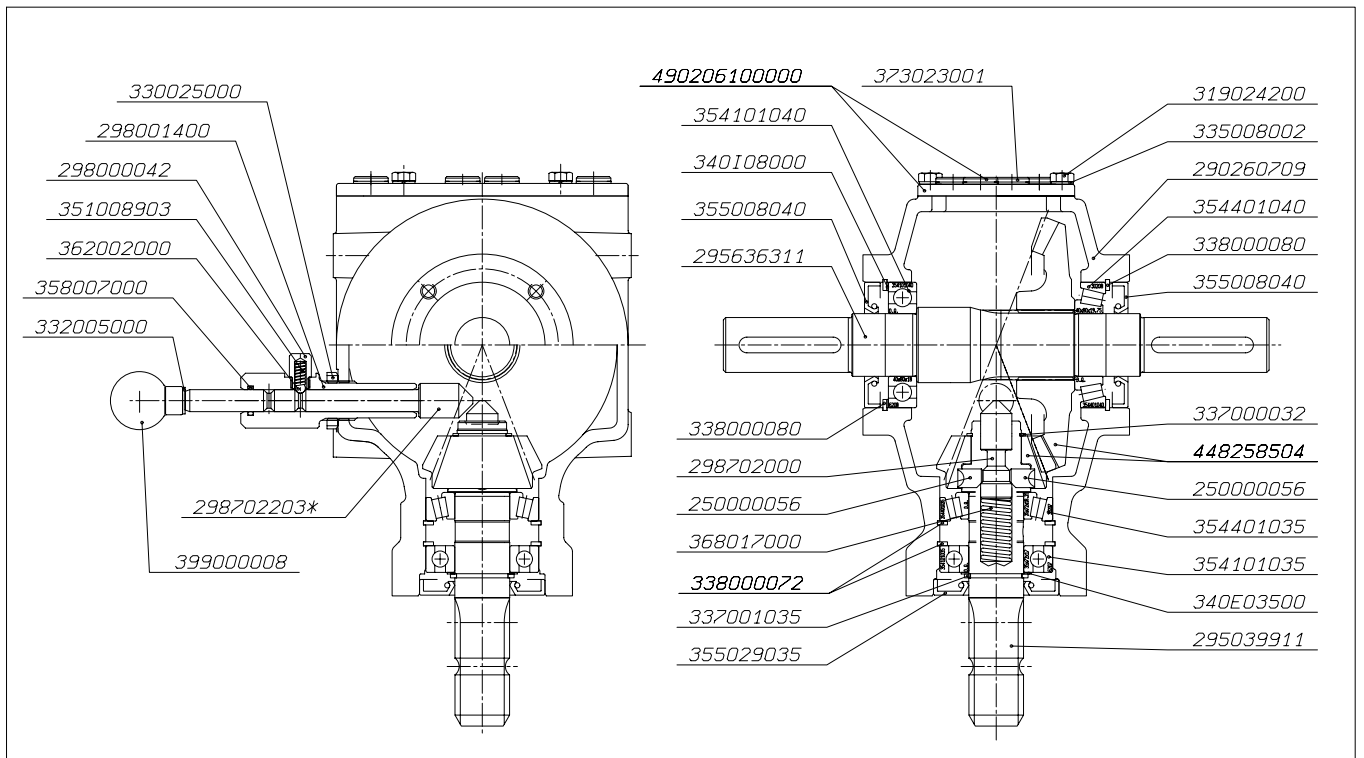

Warranty: This machine is guaranteed for 12 months. No warranty is given where the machine is being used as a hire machine. Warranty is against faulty workmanship or parts, with the exception of components not of MAJOR'S manufacture or design, i.e. hydraulic components, universally jointed shafts, chains and tyres, etc., which are subject to the original manufacturers conditions. To register your machine for warranty, please go to the support section of our website www.major-equipment.com and enter your details.

MAJOR
WWW.MAJOR-EQUIPMENT.COM

The Grass & Slurry Machinery Specialists
Agricultural ~ Professional Grounds care ~ Industrial

Home Products About Us Gallery Dealers News **Support** Contact Us

You are in: English >> Support

Support

Product Registration

Please click here to register your machine. We are committed to providing you with excellent products and product support. Please register your machine to ensure you get the correct warranty cover and service bulletins.

Product Support

Please click here to access operator manuals.

Dealer Support

Please click here for access to our dealer support area.

- Support
- Product Registration
- Operator Manuals & Spare Parts Books
- Dealer Support
- Support Contact
- FAQ

follow us on facebook

Recent News

- ▶ 3100LGP With Raingun
- ▶ New Website Launch!
- ▶ Major Heads For Oz
- ▶ Visit Our Facebook Page
- ▶ 2012 Shows

MAJOR
WWW.MAJOR-EQUIPMENT.COM

Head Office:
Ballyhaunis, Co. Mayo
Ireland
Tel: + 353 (0) 949630572
info@major-equipment.com

UK Office:
Major Ind. Estate, Heysham
Lancs, LA3 3JJ
Tel: + 44 (0) 1524 850501
ukinfo@major-equipment.com

Nederland (& Deutschland):
Postbus 29, NL-7700 AA Dedemsvaart
Nederland
Tel: + 31 (0) 6389 19585
euinfo@major-equipment.com



HEAD OFFICE

Major Equipment Intl Ltd
Ballyhaunis, Co Mayo
Ireland
Tel: +353 (0) 9496 30572

UK OFFICE

Major Equipment Ltd
Major Ind. Estate, Heysham,
Lancs, LA3 3JJ, UK
Tel: +44 (0) 1524 850501

Netherlands & Germany OFFICE

Major Equipment Intl Ltd
Postbus 29, NL-7700 AA
Dedemsvaart, Nederland
Tel: + 31 (0) 6389 19585