

# Operator Manual & Parts List

## MAJOR

### SWIFT ROLLERMOWERS

MJ70-190

MJ70-240

MJ70-320



## Head Office

Major Equipment Intl. Ltd.  
Ballyhaunis,  
Co. Mayo,  
Ireland.

Tel.: +353 (0) 9496 30572  
Fax: +353 (0) 9496 30788  
Email: [info@major-equipment.com](mailto:info@major-equipment.com)

## UK Office

Major Equipment Ltd.  
Major Industrial Estate,  
Middleton Rd.,  
Heysham,  
Lancs.  
LA3 3JJ

Tel.: +44 (0) 1524 850 501  
Fax: +44 (0) 1524 850 502  
Email: [ukinfo@major-equipment.com](mailto:ukinfo@major-equipment.com)

## NETHERLANDS & GERMANY OFFICE

Major Equipment Intl. Ltd.  
Postbus 29,  
NL-7700 AA ,  
Dedemsvaart,  
Nederland.

Tel: +31 (0) 6389 19585  
Email: [euinfo@major-equipment.com](mailto:euinfo@major-equipment.com)

Web: [www.major-equipment.com](http://www.major-equipment.com)



Find us on FACEBOOK  
MAJOR MACHINERY



View our channel  
MAJOREQUIPMENT

## Disclaimer

While every effort has been made in the production of this manual to ensure that the information contained herein is full and correct, Major assumes no responsibility for errors or omissions.

Major reserves the right to modify the machinery and the technical data contained within the manual without prior notice.

Further to this, Major assumes no liability for any damages which may result from the use of the information contained within this manual.

# Contents

## Introduction

Thank you	1
Using Your Operator's Manual	1
Safety Aspects	1
Intended use	1

## Product Identification

Machine Serial Numbers	1
Register Your Product and Warranty Online	1
Product Specifications	2

## Safety

Machine Safety Labels	2
Hazards associated with operating Grass Cutting Machinery	3
Operating Safely	4
Workstation	4
Regulations for use of the transmission	4
PTO Shaft Safety	5
Driving Safely on Public Roads	5

## Operating the Machine

Key to Main Parts	6
Inspections before Use	7
Starting Regulations	7
Attaching the machine to the Tractor	8
Operating the Machine/Mowing	8
Roller and Castor wheels adjustment	9

## Maintenance

PTO Shaft Maintenance	10
Blade Rotation	10
Wing shafts alignment	11
Greasing Schedule	11
Gearbox Oil	11
Troubleshooting	11

## MJ70 Spare Parts

MJ70-190 - General Assembly	14
MJ70-190 - Underbody Assembly	15
MJ70-190 - Drivetrain and Roller Height Asjuster Assembly	16
MJ70-190 - Parts List	17
MJ70-240 - General Assembly	18
MJ70-240 - Underbody Assembly	19
MJ70-240 - Drivetrain and Roller Height Asjuster Assembly	20
MJ70-240 - Parts List	21
MJ70 Blades	22

## **EEC certificate of conformity for machines**

*(conforming to Directive 98/37/EEC)*

Company: Major Equipment Ltd.  
Address: Coolnaha,  
Ballyhaunis,  
Co. Mayo,  
Ireland.  
Tel. +353949630572  
Fax +353949630788

*declares in sole responsibility that the product:*

### **MJ70 ROLLERMOWER (SWIFT)**

When properly installed, maintained and used only for it's intended purpose, complies with all the essential Health & Safety requirements of:

- **THE SUPPLY OF MACHINERY (SAFETY) REGULATIONS 2008.**
- **S.I. No. 299 of 2007**, Safety, Health and Welfare at Work (General Application) Regulations 2007 (Ireland).
- **Health & Safety at Work, etc. Act 1974 (c.37) (UK).**
- **EN ISO 14121-1: 2007** 'Safety of machinery. Principles for risk assessment'.
- **EN 745** - Agricultural Machinery - Rotary Mowers and Flail Mowers - Safety.
- **EN ISO 13857** - Safety of machinery: Safety distances to prevent hazard zones being reached by upper and lower limbs.

I certify on behalf of Major Equipment Int. Ltd., that this machine when properly installed and operated correctly, complies with all the essential Health & Safety requirements of all legislation referred to above.

Signature :   
\_\_\_\_\_  
Managing Director

Date 12/06/2013

# Introduction

## Thank you

We appreciate having you as a customer and wish you many years of safe and satisfied use of your machine.

## Using Your Operator's Manual

This manual is an important part of your machine and should remain with the machine when you buy it. Reading your operator's manual will help you and others avoid personal injury or damage to the machine. Information given in this manual will provide the operator with the safest and most effective use of the machine.

Sections in your operator's manual are placed in a specific order to help you understand all the safety messages so you can operate this machine safely. You can also use this manual to answer any specific operating or servicing questions.

## Safety Aspects

Your manual contains special messages to bring attention to potential safety concerns, machine damage as well as helpful operating and servicing information. Please read all the information carefully to avoid injury and machine damage.

## Intended use

This machine is a grass cutting machine and designed for cutting grass. Moreover, it must only be used with a suitable tractor (see "Product Specifications" section of this booklet) and driven by an adequate drive-line of the tractor PTO. All other use is strictly prohibited.

# Product Identification

## Machine Serial Numbers

If you need to contact MAJOR or your MAJOR dealer for information on servicing or spare parts, always provide the product model and serial numbers. Model and Serial number can be found on the Serial Plate located on the machine.

We suggest that you record your machine details below:

Model No: \_\_\_\_\_

Serial No: \_\_\_\_\_

Date of Purchase: \_\_\_\_\_

Dealer Name: \_\_\_\_\_

Dealer Telephone: \_\_\_\_\_



## Register Your Product and Warranty Online

To register your product through the Internet, simply go to the Support section on [www.major-equipment.com](http://www.major-equipment.com). Completing the information, either online or with the product warranty card, will ensure the customer that their product receives all post sales service and important product information.

This machine is warranted for 12 months with. No warranty is given where the machine is being used as a hire machine. Warranty is against faulty workmanship or parts.

Warranty covers parts only. All parts must be returned to the manufacturer. No warranty can be considered unless parts are returned. All replacement parts will be supplied on a chargeable basis until warranty has been accepted.

## Product Specifications

Model	MJ70-190	MJ70-240	MJ70-320
Overall Width	2.00m (6'6")	2.50m (8' 3")	3.3m (11' 2")
Working Width	1.90m (6'3")	2.40m (8'4")	3.2m (11')
No. of Blades	12	16	20
No. of Rotors	3	4	5
Power (HP)	25-50	30-60	35-130
PTO (rpm)	540	540	540
Blade tip speed	75m/s	75m/s	75m/s
Cutting Height	10-150mm	10-150mm	10-150mm
Weight	445kg	529kg	870kg

## Safety

### Machine Safety Labels

The machine safety labels shown in this section are placed in important areas on your machine to draw attention to potential safety hazards.

On your machine safety labels, the words DANGER, WARNING, and CAUTION are used with this safety alert symbol. DANGER identifies the most serious hazards.

The operator's manual also explains any potential safety hazards whenever necessary in special safety messages that are identified with the word, CAUTION, and the safety-alert symbol



To avoid injury, read the manual

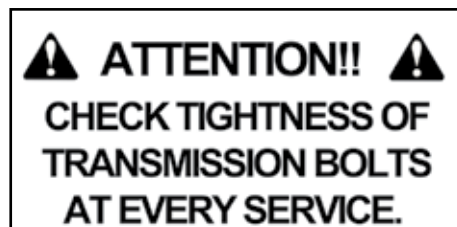

Check the tightness of the transmission



PTO entanglement hazard - keep clear of PTO drives.

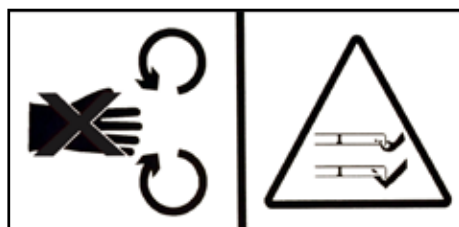

Rotating blade hazard

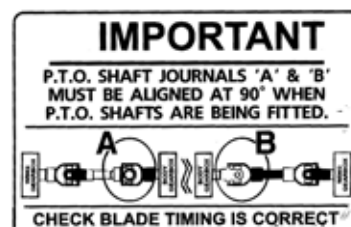

Shaft alignment

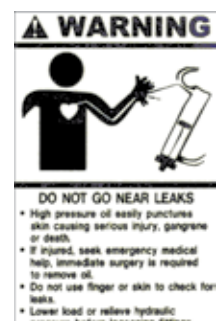

High oil pressure hazard



Grease points



Moving parts



Maximum speed

## Hazards associated with operating Grass Cutting Machinery

### Shear Hazard

Shear hazards are created when the edges of two objects move toward or next to each other closely enough to cut relatively soft material. This can include the parts of the machine under hydraulic control when operating from transport to mowing position. Note, the wing units are designed to float independently of the centre deck & are free to move within operating limits.

### Crush Hazard

Bystanders can be injured when machine is lowered into mowing position. Winged machines have crush points around the hinge areas & between the wing & main body. Always use transport locking bars when not in use (winged models only).

### Rotating Blade Hazard

All persons are at risk if they place their hands or feet under the machine when it is raised from the ground when the blades are in motion.

### Pinch Hazard

Pinch points are created when two objects move together, with at least one of them moving in a circle. This hazard is common in power transmission devices such as Belt Drives, Gear Drives & Rollers. Ensure all guarding is present.

### Wrap Hazard

Any exposed, rotating machine component is a potential wrap point. Injuries usually occur when loose clothing or long hair catch on and wrap around rotating parts such as PTO shafts or Drive shafts on the machine. Ensure all guarding is present.

### Free-wheeling parts Hazard

The heavier a revolving part is, the longer it will continue to rotate after power is shut off. This characteristic is called 'free-wheeling.' Blades, and various other components, drive shafts etc., will continue to move after power is shut off - often for several minutes. Injuries occur when:

- Operators shut off equipment, and attempt to clean or adjust a machine before components have completely stopped moving.
- Shear bolt protection device in PTO shaft shears & the mowing parts are still spinning but the primary PTO shaft is stationary. Operator awareness is the key to safety around freewheeling parts. Never raise the machine while the blades are still rotating.

### Thrown objects Hazard

Machines throw material as a natural part of doing their job. Foreign objects, such as stones, sticks and other debris, may be taken into this equipment and expelled at tremendous speed. These objects are contained by the sides of the machine and by the rear/front rollers / guards / chain guards / rubber skirts depending on model of your machine.

Ensure bystanders are clear from the machine & cannot be hit with debris expelled from the machine. Bystanders or animals in the path of thrown objects could be seriously injured. Never operate machine with decks raised from the ground as this makes the front/rear protection redundant.

### Hydraulic Hazard (if applicable)

Hydraulic systems store considerable energy. Careless servicing, adjustment, or replacement of parts can result in serious injury. High pressure blasts of hydraulic oil can injure eyes or other body parts. The following precautions are crucial:

- Make certain the hydraulic pump is turned off.
- Lower attached equipment to the ground.
- Confirm that load pressure is off the system.

A pinhole leak in an hydraulic hose is a serious hazard. A leak may not be visible, and the only sign may be a few drops of fluid. Never inspect hydraulic hoses with your hands, because a fine jet of hydraulic fluid can pierce the skin.

### Slips, Trips and Falls Hazard

Slips and falls often result from:

1. Slippery footing on the ground
2. Cluttered steps and work platforms.

The potential for slips and falls can be greatly reduced by using good judgement and practicing good housekeeping on and around equipment.



## Noise Hazard

Please note that the machine is normally used outdoors and that the position of the operator is seated in the driving seat of the tractor. It is advisable to consult the prescriptions listed in tractor operator and maintenance manuals.

The acoustic pressure at a distance of 2.6m from the centre of the machine and at a height of 2.0m, with the implement operating in a no load condition can reach 90 dBA. In a loaded condition & a PTO rate of 540 rpm the value can reach 97dBA. Higher rate of PTO input will result in in higher noise levels. Always wear hearing protection.

## Operating Safely

This MAJOR machine is designed to operate at a PTO rate which is stated in the Product Specifications part of this booklet. Ensure tractor PTO output is set at a correct RPM rate. This MAJOR machine must only be used for purposes outlined in the Intended Use section of this booklet. All other use is strictly prohibited.



Users should become thoroughly familiar with the contents of this manual before using, servicing and mounting the implement to the tractor and all other pertinent operations. Never wear jewellery, loose clothing such as ties, scarves, belts, unbuttoned jackets or dungarees with open zips which could become caught up in moving parts.



Always wear approved garments complying with accident prevention provisions such as non-slip shoes, ear muffs, goggles and gauntlets. Wear a jacket with reflecting stickers if the implement is used near public highways.



Consult your retailer, the Labour Health Service or your nearest equivalent authority for the information about the current safety provisions and specific regulations with in order to ensure personal safety.



**ALWAYS DISENGAGE PTO, SWITCH OFF THE TRACTOR ENGINE AND ENGAGE THE PARKING BRAKE BEFORE MAKING ADJUSTMENT TO THE MACHINE.**



**NEVER PLACE LIMBS UNDER THE MACHINE WHILE ROTOR(S) ARE TURNING. ROTOR(S) CAN REMAIN TURNING FOR UP TO 1 MINUTE AFTER DISENGAGING PTO.**

## Workstation

The operator must remain seated while working the machine. If the machine is a winged unit and the wings need to be raised/lowered the operator must not leave the tractor. Always ensure the PTO has been turned off and the parking brake applied before leaving the tractor cab or carrying out maintenance.



**NEVER OPERATE THE HYDRAULICS WITH THE TRACTOR SWITCHED OFF**

## Regulations for use of the transmission

The transmission to the gearboxes is protected throughout the machine by both PTO shafts and bolt down covers. All guarding should be kept efficient and in good condition. If the condition is poor, the guarding should be renewed before the implement is used.



**UNLESS IT IS CORRECTLY PROTECTED THE TRANSMISSION COULD CAUSE DEATH SINCE IT CAN CATCH ON PARTS OF THE BODY OR CLOTHING**

Ensure retaining chains are correctly anchored on all PTO shafts, preventing them from turning. Ensure drive line can turn easily within the shield. Keep spline grooves clean and greased so that PTO shaft can connect easily. Besides being described in this booklet, the method by which the PTO shaft is connected to the tractor must be checked out with the instructions in the tractor manufacturer's manual.



## PTO Shaft Safety

Maximum PTO input is specified in the Product Specifications section of this booklet. Contact your nearest dealer or a specialised retail outlet if the PTO must be replaced with a longer one, since this must belong to the same power category and possess the same characteristics. An unsuitable PTO could easily break.

The tractor PTO shaft length may be altered to suit the individual tractor model. When the machine is in operation, the PTO shaft should have a minimum 1/3 engagement as shown in the diagrams. After the machine has been hitched to the tractor, it should be checked in various positions that the drive line is the correct length. If the PTO is too short and tends to slip out of place, it must be replaced with a longer one.

If the PTO shaft is too long, it should be shortened in the following way:

- Set the machine at a minimum distance from the tractor, then brake the tractor and switch off the engine.
- Separate the two halves of the PTO. Insert the female part into the tractor PTO and the male part into the machine PTO, checking that the position is correct by means of the fixing pins.
- Line up the two halves of the PTO together, keeping them parallel.
- Using a felt tip pen, match mark the place where the two halves must be shortened as shown.
- First cut shield "1" and use part "2" as a reference to cut the splined shaft.
- Proceed in the same way for the second half.
- Trim and chamfer the two cut ends of the PTO and clean off all swarf and shavings.
- Grease the two profiles and join the two halves of the PTO together.
- Mount the PTO shaft and check that its length is correct as before.



Do not use the shaft cone as a step

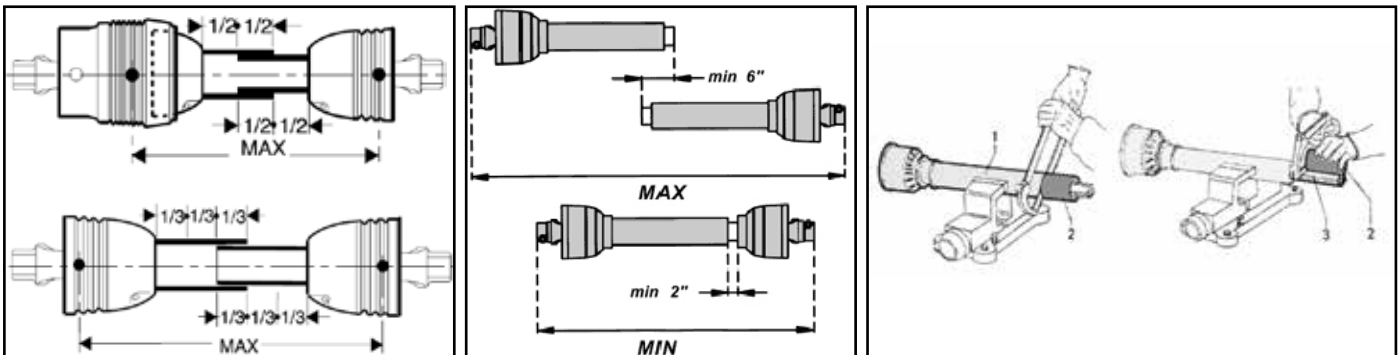

## Driving Safely on Public Roads

Check the local Highway Code regulations before driving the tractor on public highways with an implement attached. Check the reflectors, hazard flashers and/or projecting load indicators are installed when required and efficient. These indicators must be installed correctly and easily seen by the drivers of other vehicles.

Bystanders must not be allowed to lean against or climb onto the machine during transport or while working. Do not allow bystanders to ride on the machine.



MAXIMUM TRANSPORT SPEED MUST NOT EXCEED 30 km/hr (18 MPH)

## General safety instructions

Precautions to be taken while working with the machine:

1. Do not operate the machine when you are tired;
2. Before starting mowing, make sure that the area is clear of people or animals.
3. Before starting adjusting the machine, it is mandatory to disconnect the PTO, to turn off the engine of the tractor, apply handbrake and wait for the turning parts to become still and placed on the ground.
4. It is mandatory to read all the safety requirements and the operator's manual of the machine.
5. If you are not sure how to use the machine, please contact the manufacturer or the dealer.

# Operating the Machine

This machine is designed to be connected to a tractor by using a standard 3 point linkage connection. It can be installed either to the front or to the rear of the tractor, depending on the model of your machine.

## Key to Main Parts

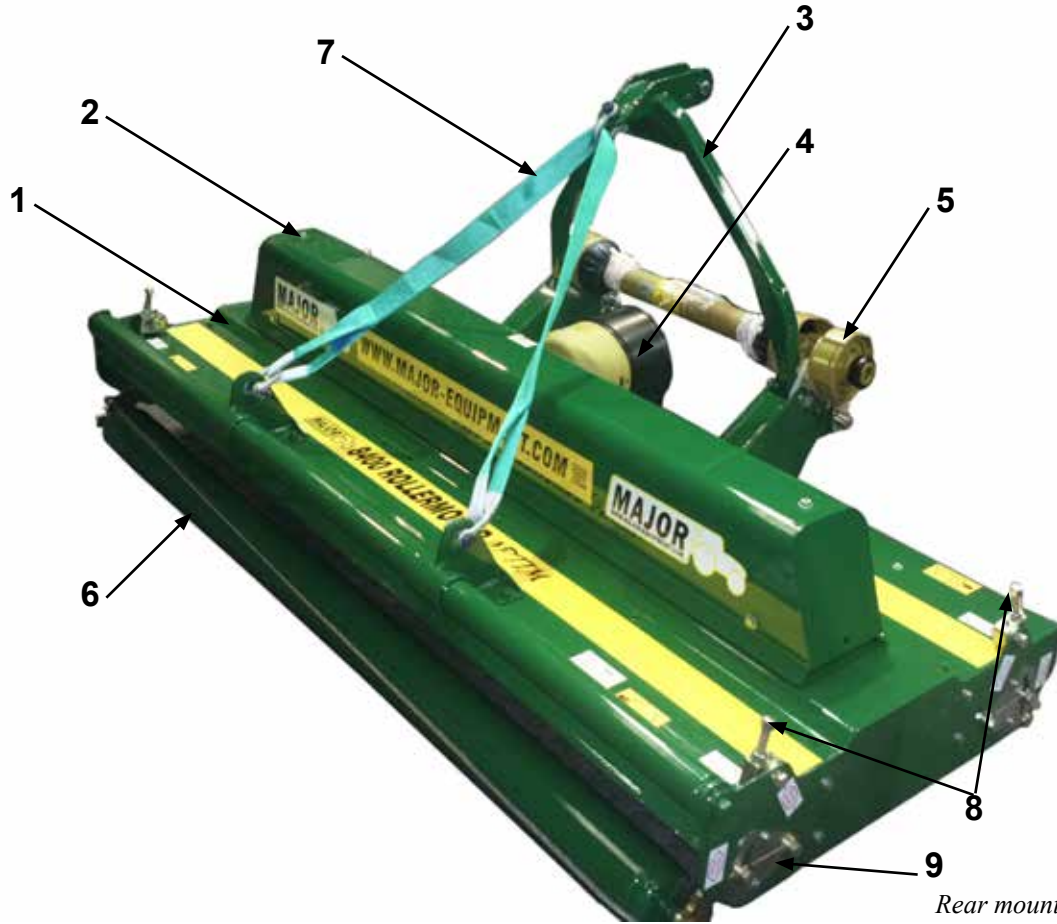

Rear mounted machine shown

- |    |                            |
|----|----------------------------|
| 1  | Body                       |
| 2  | Drivetrain cover           |
| 3  | A-Frame                    |
| 4  | Gearbox PTO cover          |
| 5  | PTO shaft                  |
| 6  | Rear roller                |
| 7  | Strap                      |
| 8  | Roller height adjuster rod |
| 9  | Roller height indicator    |
| 10 | Top Link                   |
| 11 | Blade                      |
| 12 | Front roller               |
| 13 | Scrapper bar               |

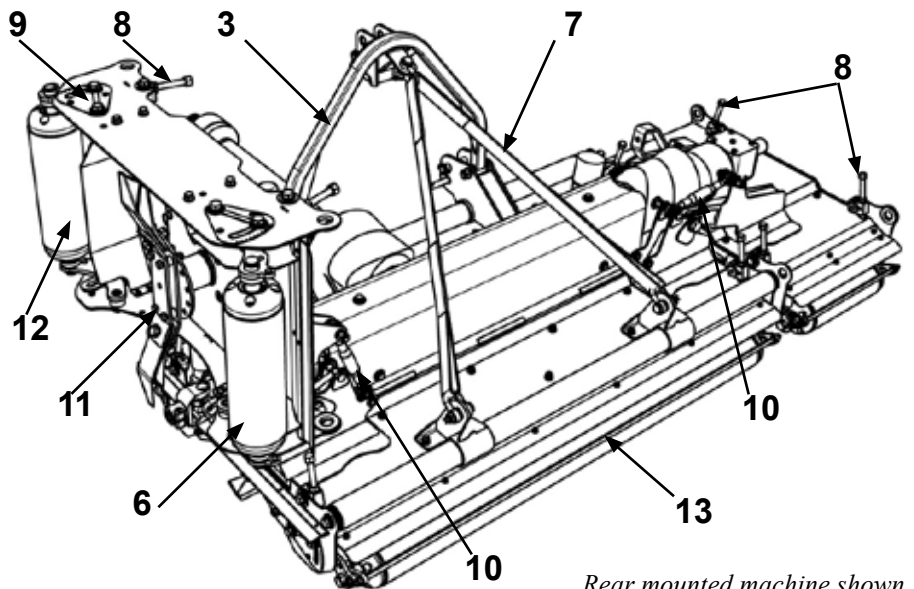

Rear mounted machine shown

## Inspections before Use



Always disengage PTO, Switch off tractor engine and engage the parking brake before making adjustments to the machine.

1. With the whole machine as level as possible, check the oil level in the Primary and Rotor Gearboxes and top up as required with recommended gear oil through the oil filler plug indicated. The correct level is at the oil level plug indicated.

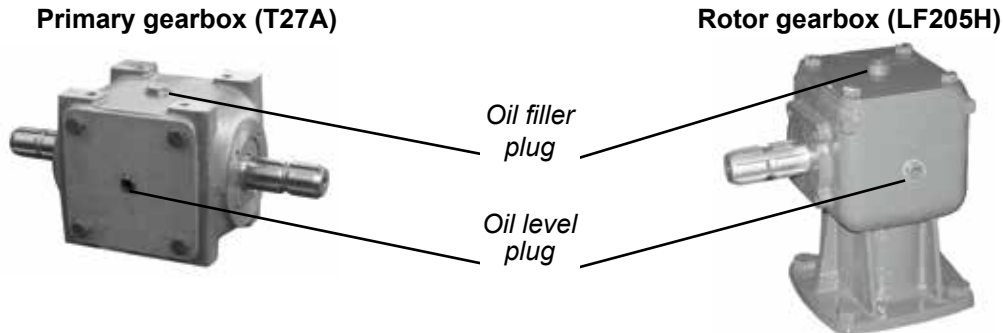

2. Grease the PTO shaft universal joints, drive shaft bearing and carrying arm pivots.
3. Check the blades for wear and damage and replace worn blades with new ones if required.
4. If the blade assembly is removed check the blade mounting ensure the gearbox shaft nut is tight and retained in place by split pin.

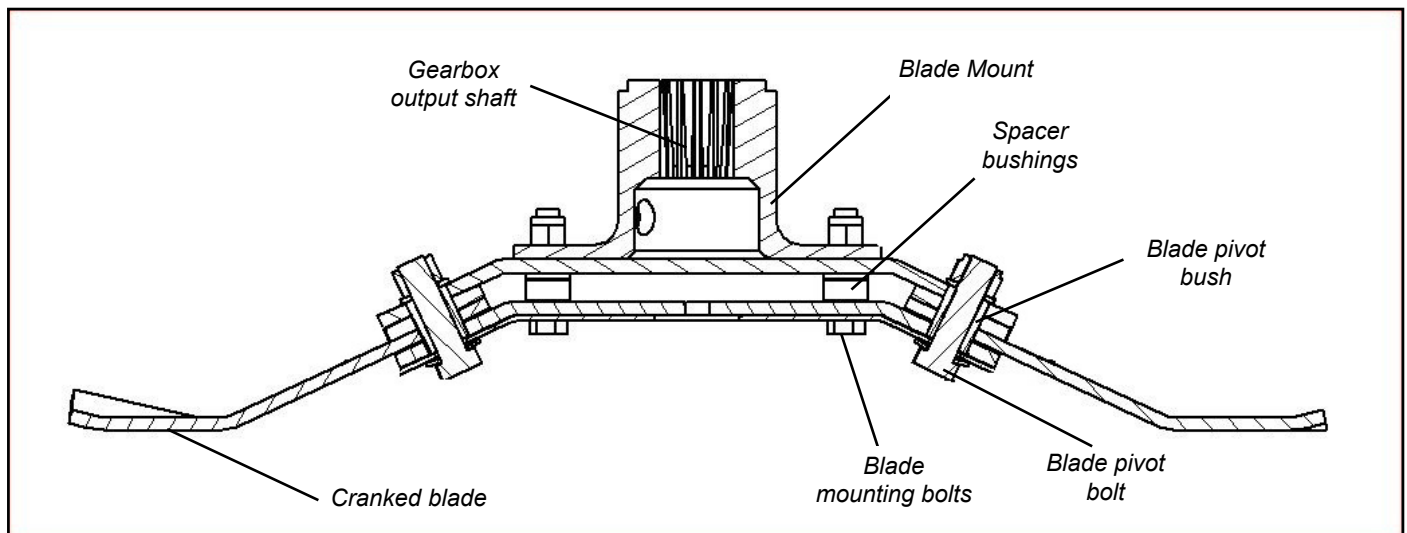

5. Check tightness of all nuts, bolts and retaining screws after the first and second hours of work.
6. Ensure safety guards and flaps are in place at all times where fitted. If these become worn or missing, replace them immediately with new ones.
7. Due to the corrosive nature of grass when cut, wash down the machine when finished mowing, especially when the machine is being stored for a long period of time.

## Starting Regulations



Always check that any imminently dangerous conditions have been eliminated before using the machine. Ensure all guarding is present & the operator is fully aware of the operations of the machine.



Always ensure the pins lock the PTO shaft yoke ends onto the spline shafts on both the tractor and the implement. An unlocked shaft could slip out of position, causing notable mechanical damage and serious injury to both operator and bystanders.

## Attaching the machine to the Tractor



Always operate on level ground when attaching/detaching the machine. This will prevent dangerous movement. Never allow anyone to stand between the tractor and the machine.

### Three Point Linkage Models

1. Adjust both lift arms of the tractor until they are level in relation to each other.
2. Hitch the lower linkage arms to the Machine and connect the top link and PTO shaft. Ensure that the locking pins are secure.
3. With the Machine lowered in its operating position, adjust the top link until the strap is slack, allowing the Machine to produce a uniform finish in varying ground conditions.
4. Connect the PTO shaft. Check for the length

### Trailed Models

1. Adjust the tractor hitch pin so that the hitch pin is approximately 400 mm (16") from the end of the tractor PTO shaft.
2. Adjust the machine hitch eye to suit the tractor drawbar height paying particular attention to keep both height adjusting bolts as far as possible on the adjusting bracket. Careful adjustment of the hitch eye height at this stage is necessary in order to allow the machine to function safely and correctly.
3. Connect the machine to the tractor. Ensure no one is standing between the tractor and the Machine.
4. Before connecting the PTO shaft to the tractor, check it for length as shown earlier.

### Transport Position



Before raising the machine wait until the transmission and the blades are completely still.

During the transport of the machine it is recommended that the PTO shaft is disconnected.

1. Check machine is hitched to the tractor as described. Ensure the tractor parking brake is applied
2. Ensure moving parts become still then transform the machine into transport position by hydraulic control
3. During the transport and any time the machine shall be raised, the raising device shall be adjusted to assure that the machine is at least 250mm over the ground.

### Top link position (Winged models only)



## Operating the Machine/Mowing



Never place limbs under the machine while rotors are turning. Rotors can remain turning for up to 1 minute after disengaging PTO.



While operating this machine the PTO input rate should not exceed the RPM stated in the Product Specifications section of this booklet. Always operate on level ground when connecting/disconnecting the implement. This will prevent dangerous movement.



Never allow anyone to stand between the tractor and the machine. Ensure the machine is attached correctly to the tractor as previously described. Always start up the tractor PTO at a low RPM. Build up to operating speed, select a suitable forward gear & proceed to cut grass.

1. Hitch the machine as outlined in the previous section. Ensure bystanders are clear from the machine & cannot be hit with debris expelled from the machine.
2. Locate the Parking Jack on its side under the PTO shaft on the stub provided (Trailed models only)
3. Ensure the PTO stand is flipped down. (Trailed models only)



4. Check PTO shaft is fully engaged on tractor PTO splines.
5. Raise the machine by hydraulic control. (Trailed models only)
6. Flip back axle and drawbar ram stoppers. (Trailed models only)
7. Lower the machine by hydraulic control to the ground or use tractor linkage controls.
8. After clearing the vicinity of bystanders, relocate the Wing Transport Locking Bars. Lower the wings by hydraulic control. Ensure hydraulic ram is fully closed. (Winged mowers only).
9. Start up the tractor PTO at a low RPM.
10. Build up to operating speed, select a suitable forward gear & proceed to cut grass.

## Roller and Castor wheels adjustment

In order to achieve desired cutting height, castor wheels and roller should be adjusted.

### Castor wheels (optional)

To adjust the height of front wheels lift up the machine and:

1. Remove Lock Pin **A**;
2. Slide down the Castor Yoke **B** and remove it;
3. Depending on the desired cutting height place Spacers **C** above or below Castor Arm **D**.
4. When adjustment is complete, relocate Castor Yoke **B** and secure it with Lock Pin **A**.
5. Repeat this procedure for the other wheel.

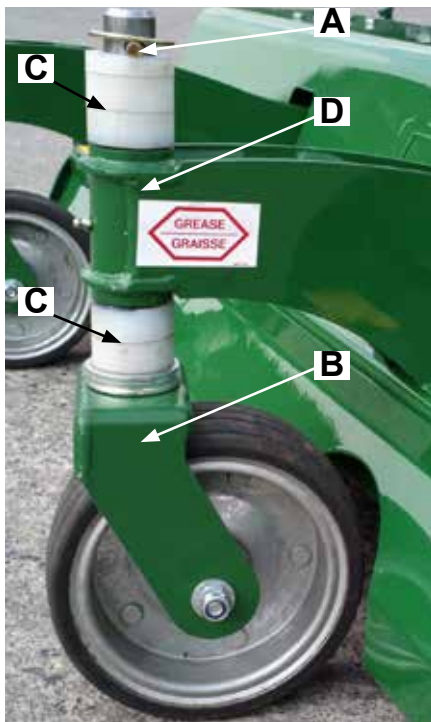

### Roller

To adjust the height of the roller follow this procedure at both sides of the roller:

1. Loosen Bolts **B** and **C** (Note: You do not have to remove these bolts, half of the turn will suffice to allow movement);
2. Turn Nut **D** clockwise to increase the cut height or anti-clockwise to decrease the cut height;
3. Match the height of the roller on both sides of the machine by checking the position of Arrow **A**;
4. When adjustment is complete, re-tighten Bolts **B** and **C**.

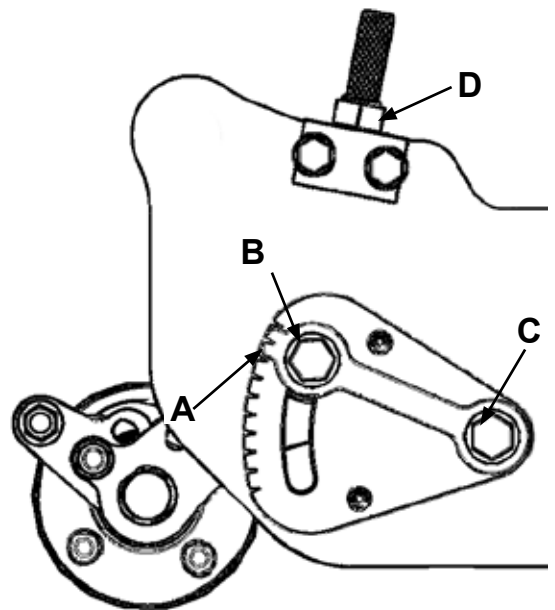

### Scraper bar

Scraper bar is supplied as an optional extra. In order for a scraper bar to function properly, it should be kept tensioned. To tension the scraper bar (1) tighten up nuts (2) at both ends of the roller (3). Locate the scraper bar bracket (4) in a desired position by loosening/tightening bracket nut (5).

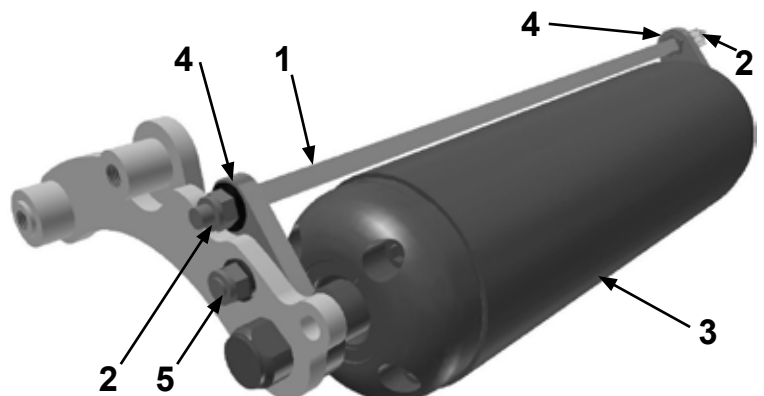

# Maintenance

The machine must always be disconnected from the tractor before any cleaning, lubricating and servicing operations can be carried out. Maintenance must be carried out by qualified personnel.

If emergency operations are required whilst the machine is connected to the tractor, switch off the engine, engage the parking brake and disengage the PTO.

Good, regular maintenance and correct use are advised if the machine is to remain safe and long lasting.

## PTO Shaft Maintenance

### Guard Removal and Yoke End Greasing

1. Prise back locking tabs
2. Pull back PTO Guard
3. Grease points as shown
4. Push Guard into position
5. Click into place
6. Tie check chain

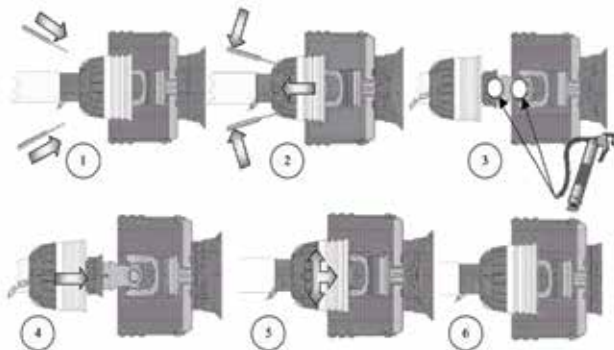

### PTO Guard Greasing Intervals

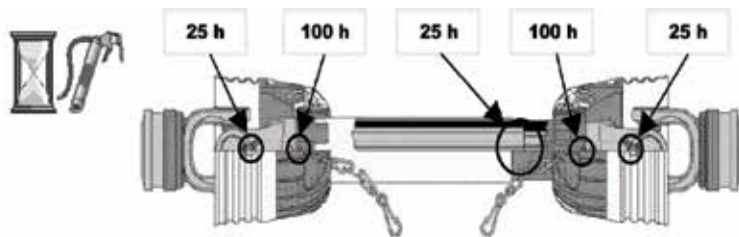

### Maintenance of other components

- All nuts and bolts in the transmission including Rubber couplings, Star Drives, PTO Shafts and Gearboxes should be checked for tightness after mowing at the following intervals:
  - 1st 40 hours
  - 1st 100 hours
  - 1st 250 hours
  - And every 250 hours thereafter.
- Check blades on a regular basis for wear. Replace any damaged or worn parts immediately.

### Blade Rotation



Ensure blade rotation and timing (90 degrees) is correct after servicing transmission.

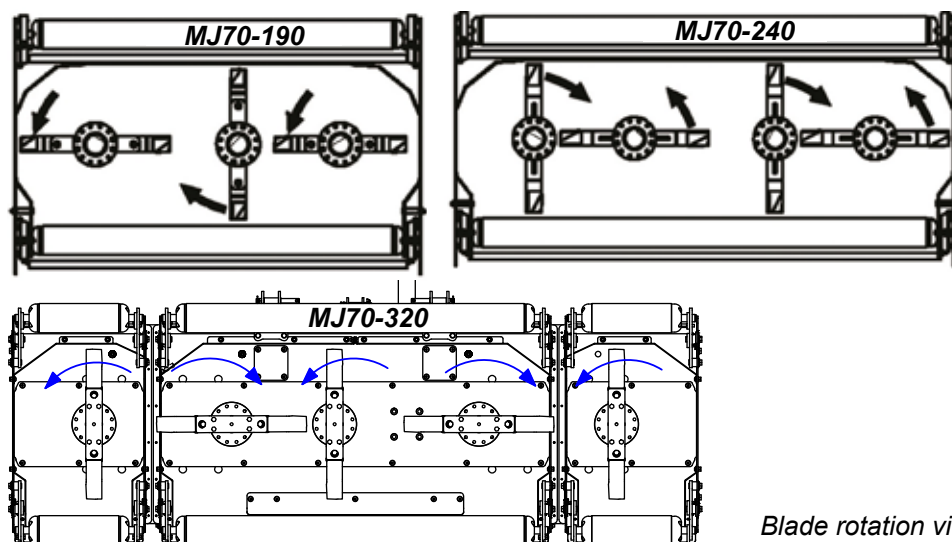

*Blade rotation viewed from underside*

## Wing shafts alignment



ENSURE THAT AFTER SERVICING THE TRANSMISSION, THE WING PTO SHAFT YOKES ARE CORRECTLY ALIGNED AS SHOWN IN THE DIAGRAM BELOW – WINGED MODELS ONLY. IF THE SHAFT JOURNALS ARE FITTED INCORRECTLY THE DAMAGE WILL ONLY OCCUR WHEN THE WINGS ARE RAISED INTO TRANSPORT POSITION.

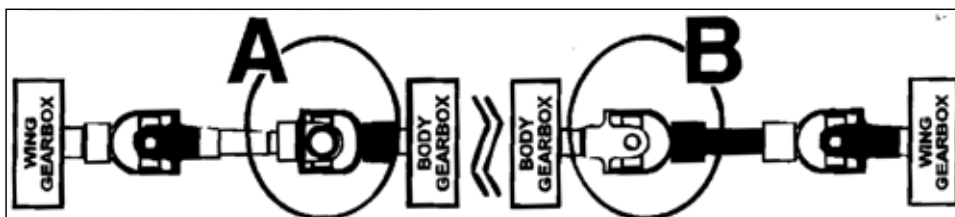

## Greasing Schedule

Lubricate moveable mechanical joints when required.

	First 8 hours	40 hours thereafter
PTO Shaft Yoke Ends	●	●
Roller height adjuster (4x3) - single deck models (12x3) - winged models	●	●
Wing pivots (4)	●	●

## Gearbox Oil

Replace oil in gearboxes after first 100 hours and then every 400 hours thereafter.

Use oil which conforms to 80W/90 standards.

## Troubleshooting

Fault	Cause	Remedy
Leaves a streak of uncut or partially cut grass	Blades dull or bent	Replace blades
	Carrier RPM too low	Use correct PTO speed
	Field conditions are so wet that the wheels are pushing grass into mud	Too wet to mow. Stop operation and wait until it is drier
	Ground speed too fast	Reduce ground speed by shifting to a lower gear
	Grass is down from previous weather conditions	Mow in only one direction
	Possible build-up materials under machine	Clean the machine
	Blades mounted incorrectly (cutting edge against direction rotation)	Change blades so that cutting edge is facing correct rotation
Material discharges from machine unevenly; bunches of material along with swath	Material too high and too much material	Reduce ground speed but maintain recommended rpm at tractor PTO or make two passes over material. Raise machine for the first pass and lower to desired height for the second and cut a 90 degree angle to first pass
	Grass wet	Allow grass to dry before mowing. Slow ground speed of tractor but keep engine running at full PTO rpm. Cutting lower will help
Gearbox overheating	Low on lubricant	Fill to proper level
	Improper type lubricant	Replace with proper lubricant
	Excessive grass/debris build-up around gearbox. PTO running too fast.	Remove grass, etc from machine. Lower the RPM rate
Blade is scalping ground	Machine too low	Raise machine - reset wheels
	Field is ridged	Cut field at a different angle
	Field is too wet	Stop and wait until it is dried



Blades wear too fast	Cutting in sandy conditions	Increase cutting height
	Cutting in rocky conditions	Increase cutting height
	Blades hitting the ground	Increase cutting height
Machine seems to require excessive power	Advancing into grass too rapidly	Reduce forward travel speed
	Hitting ground	Raise machine and reset wheels
	Worn or dull blades	Sharpen or replace blades
Excessive vibration	Check gearbox bolts	Tighten if loose
	Check for loose nuts on blades	Tighten if loose
	Blade broken	Replace blades, in set
	New blade or bolts matched with worn blade or bolts	Replace blades or bolts in sets
	Drivelines not phased correctly. Implement and tractor yokes must be in line	Phase the driveline. Replace if necessary
Noisy machine	Low oil in gearbox	Check level and add oil
	Loose Parts	Check all bolts are fully tightened
	Wrong PTO rpm rate	Check PTO rate & adjust as necessary
	Rotors bent/broken	Replace bent or missing blades
	Bent PTO shaft	Check PTO shaft aligned correctly
	Bent gearbox shaft	Check output shaft on gearboxes are not bent
		Check driveline between gearboxes is aligned
Gearbox leaking	Damaged oil seal	Replace seal
	Bent shaft	Replace oil seal and shaft
	Shaft rough in oil seal area	Replace or repair shaft
	Oil seal installed incorrectly	Replace seal
	Oil seal not sealing in the housing	Replace seal or use a sealant on outside diameter of seal
	Oil level too high	Drain oil to proper level
	Hole in gearbox	Replace the gearbox
	Gasket damaged	Replace gasket
	Bolts loose	Tighten bolts

# **MJ70 Spare Parts**

# MJ70-190 - General Assembly

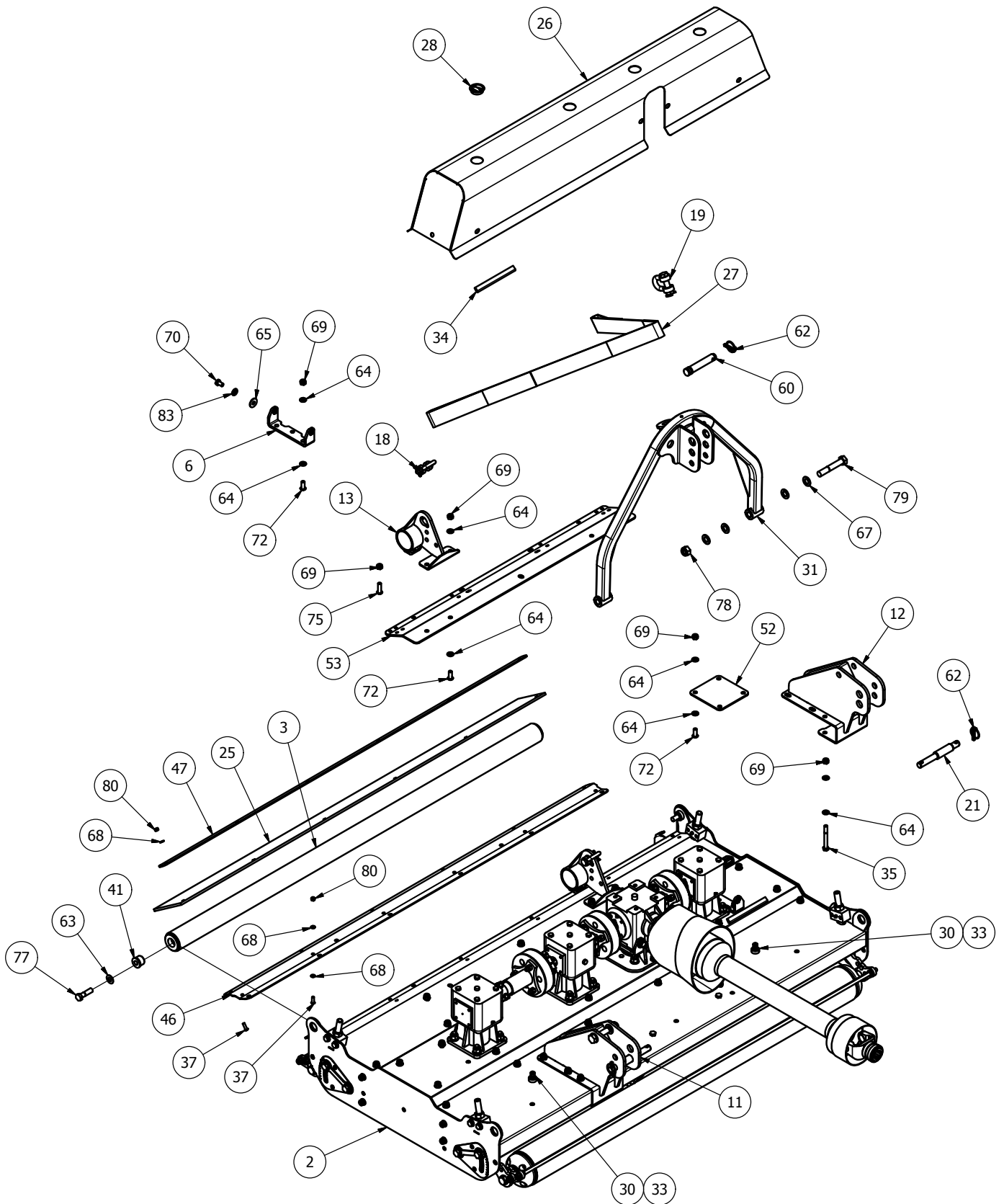

# MJ70-190 - Underbody Assembly

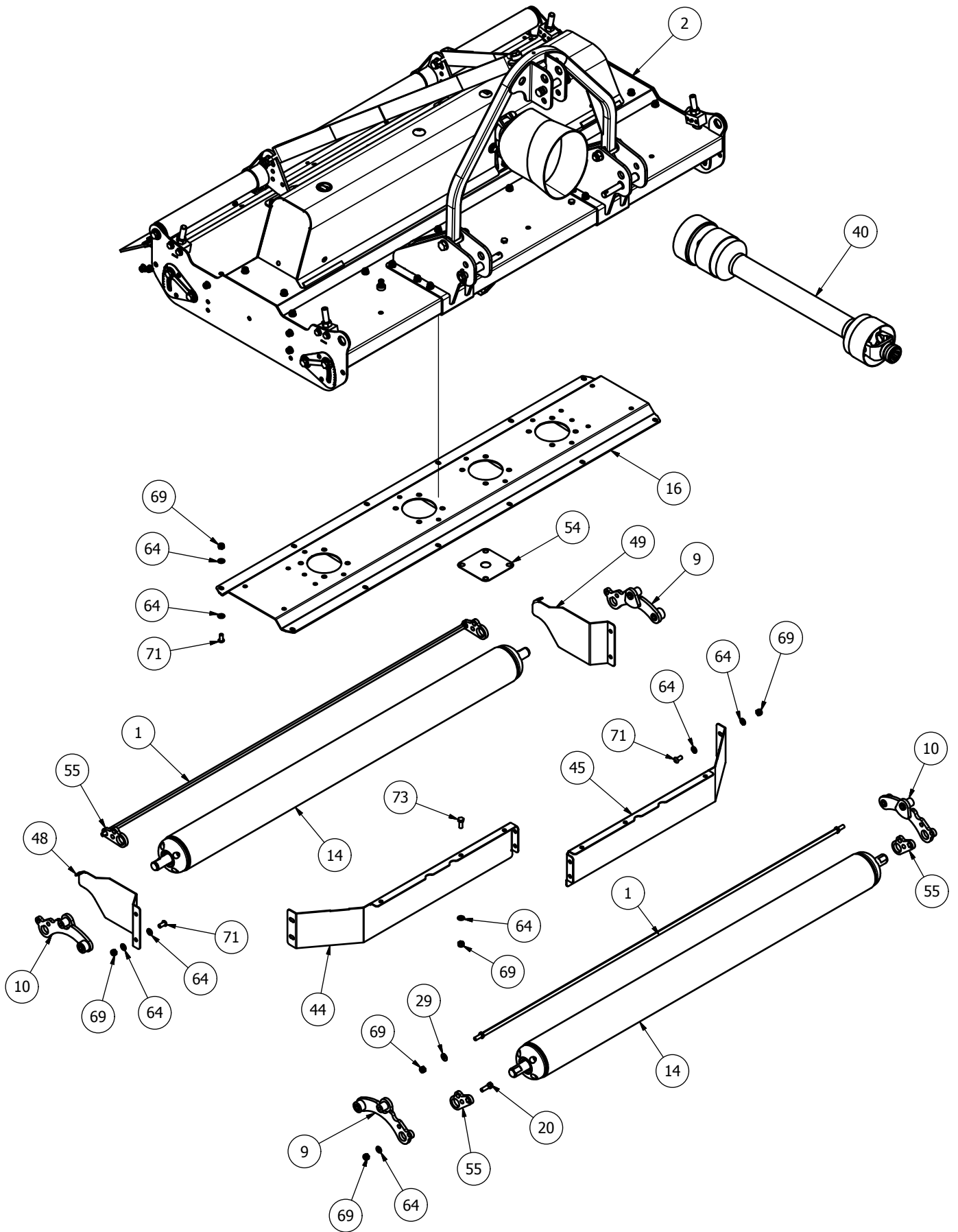

# MJ70-190 - Drivetrain and Roller Height Asjuter Assembly

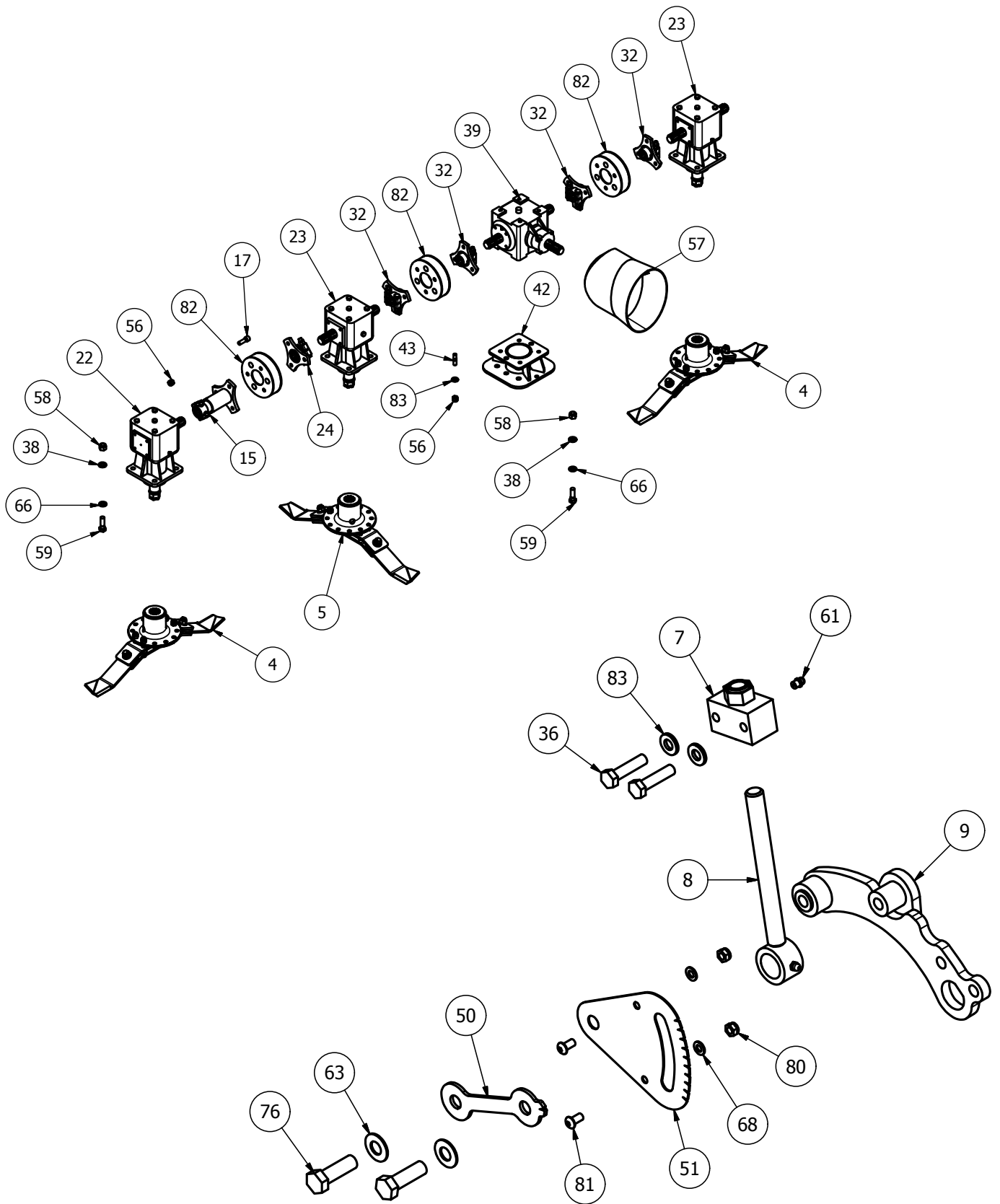

## MJ70-190 - Parts List

Item	Part No.	Description	Qty	Item	Part No.	Description	Qty
1	6300RM-SCRPR-01	6300 SCRAPER BAR	2	43	T27A-S1	T27A STUD	4
2	6300RM3-BD01	MJ70-190 BODY	1	44	6300RM-AF02	AERO-FOIL (6300)	1
3	6300RM3-TM01	6300 TUBE MOUNT	1	45	6300RM-AF02H	AERO-FOIL (6300)	1
4	725-BLD-L	725 BLADE (Anti_Clk)	2	46	6300RM3-CV21	6300 REAR COVER	1
5	725-BLD-R	725 BLADE (Clk)	1	47	6300RM3-CV23	RUBBER CLAMP	1
6	8400RM-CV14	GUARD BASE MOUNT	4	48	8400RM-GRD15	REAR DEFLECTOR	1
7	8400RM-HG55	M20 ADJUSTER BLOCK	4	49	8400RM-GRD15H	REAR DEFLECTOR	1
8	8400RM-HG65	M20 THREADED ADJUSTER	4	50	8400RM-HG03	HEIGHT INDICATOR	4
9	8400RM-RPV01	ROLLER PIVOT	2	51	8400RM-HG04	HEIGHT GUIDE	4
10	8400RM-RPV10	ROLLER PIVOT	2	52	8400RM3-LM11	LINKAGE SUPPORT	2
11	8400RM3-LM21	LINKAGE MOUNT	1	53	8400RM3-SM11	STRAP SUPPORT	1
12	8400RM3-LM21H	LINKAGE MOUNT	1	54	MJ70-240-GBR21	CENTER BOX BLANK	1
13	8400RM3-SM01	STRAP MOUNT	2	55	SCRPR-SQ12-01	SCRAPER MOUNT	4
14	GM63-ROL	6300 ROLLER	2	56	1/2F	1/2" FINE NYLOC NUT	22
15	GM84-55L	8400 DRIVE TUBE (LONG)	1	57	190.000.545	PTO GUARD (EXTENDED OVAL)	1
16	MJ70-190-GBR18	UNDERSIDE TROUGH	1	58	5/8F	5/8" FINE NYLOC NUT	16
17	12x112FSKS	1/2"x1 1/2" FINE SOCKET HEAD 12.9	18	59	58x2FBZP	5/8"x2" FINE BOLT	16
18	DSR-1-2	1/2" RATED 'D' SHACKLE	2	60	81	CAT 2 PIN DIA 25.4x110mm	1
19	DSR-5-8	5/8" RATED 'D' SHACKLE	1	61	851	GREASE NIPPLE M8x1.25 STR	8
20	M12x40BZP	M12x40 BOLT	4	62	AN099/10	LINCH PIN DIA 9.5	3
21	S15707	CAT 1/2 LINK PIN	2	63	DSW34	DISC SPRING 34x16.3 x2	10
22	205872	6 SPLINE 'L' BOX RATIO 1.92	1	64	FWM12	M12 FLAT WASHER	122
23	205874	6 SPLINE 'T' BOX RATIO 1.92	2	65	FWM12L	M12 FLAT WASHER (LARGE)	8
24	60CSD	60mm STAR DRIVE	1	66	FWM16	M16 FLAT WASHER	16
25	6300RM3-CV22	RUBBER FLAP	1	67	FWM20	M20 FLAT WASHER	8
26	6300RM3-CVR	MJ70-190 GBOX REAR COVER	1	68	FWM8	M8 FLAT WASHER	38
27	8400STR	8400RM MKII STRAP (2000mm)	1	69	M12	M12 NYLOC NUT	73
28	CP176-181MG1	45mm INSERT	4	70	M12x20SZP	M12x20 SET BOLT	8
29	D281215	DISC SPRING 28x12x1.5	4	71	M12x25SKBH	M12x25 SOCKET BUTTON HEAD 10.9	33
30	G1106	BRASS TAP CONNECTOR	2	72	M12x30SKBH	M12x30 SOCKET BUTTON HEAD 10.9	16
31	GM3	STANDARD A-FRAME	1	73	M12x30SZP	M12x30 SET BOLT	8
32	GM84-DRV	6 SPLINE STAR DRIVE	4	74	M12x35BZP	M12x35 BOLT	2
33	I-257	3/4x1/2 REDUCER BUSH	2	75	M12x40SKBH	M12x40 SOCKET BUTTON HEAD 10.9	2
34	LS002	ANTI VIBRATION RUBBER	6	76	M16x50SZP	M16x50 SET BOLT	8
35	M12x100BZP	M12x100 BOLT	4	77	M16x60BZP	M16x60 BOLT	2
36	M12x50SZP	M12x50 SET BOLT	8	78	M20	M20 NYLOC NUT	2
37	M8x25SKBH	M8x25 SOCKET BUTTON HEAD 10.9	18	79	M20x120BZP	M20x120 BOLT	2
38	NL16SP	M16 SP NORDLOCK	16	80	M8	M8 NYLOC NUT	26
39	T27A267245	6 SPLINE 'T' BOX RATIO 1.92	1	81	M8x16SKBH	M8x16 SOCKET BUTTON HEAD 10.9	8
40	T500810ENC12RW6	FIXED SLIP CLUTCH 1200 Nm	1	82	MJRC-113	113 PCD RUBBER COUPLING	3
41	8400RM3-TM04	TUBE MOUNT STUB	2	83	NL12SP	M12 SP NORDLOCK	20
42	2000CM-GBM01	CENTER BOX MOUNT	1				

# MJ70-240 - General Assembly

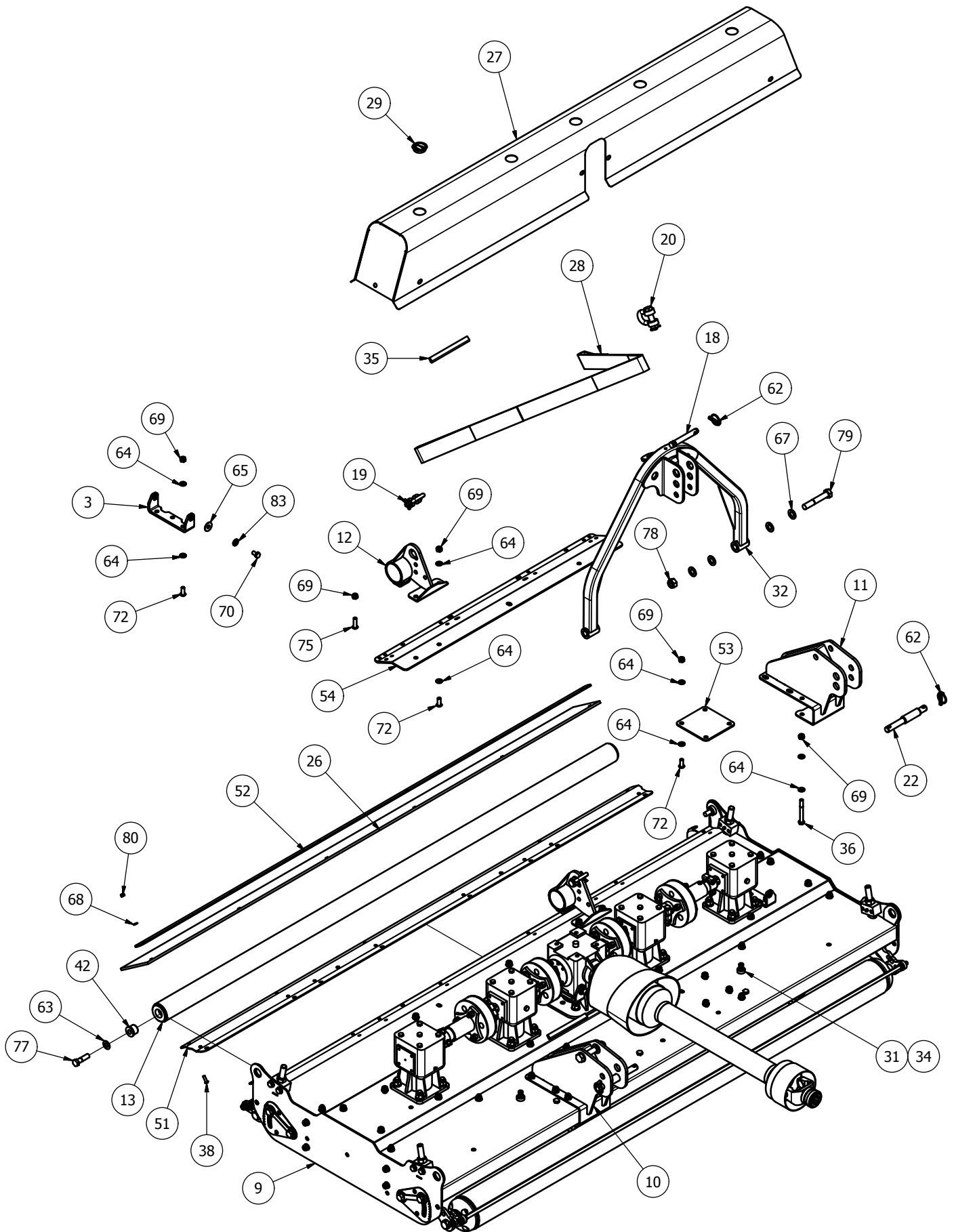



# MJ70-240 - Underbody Assembly

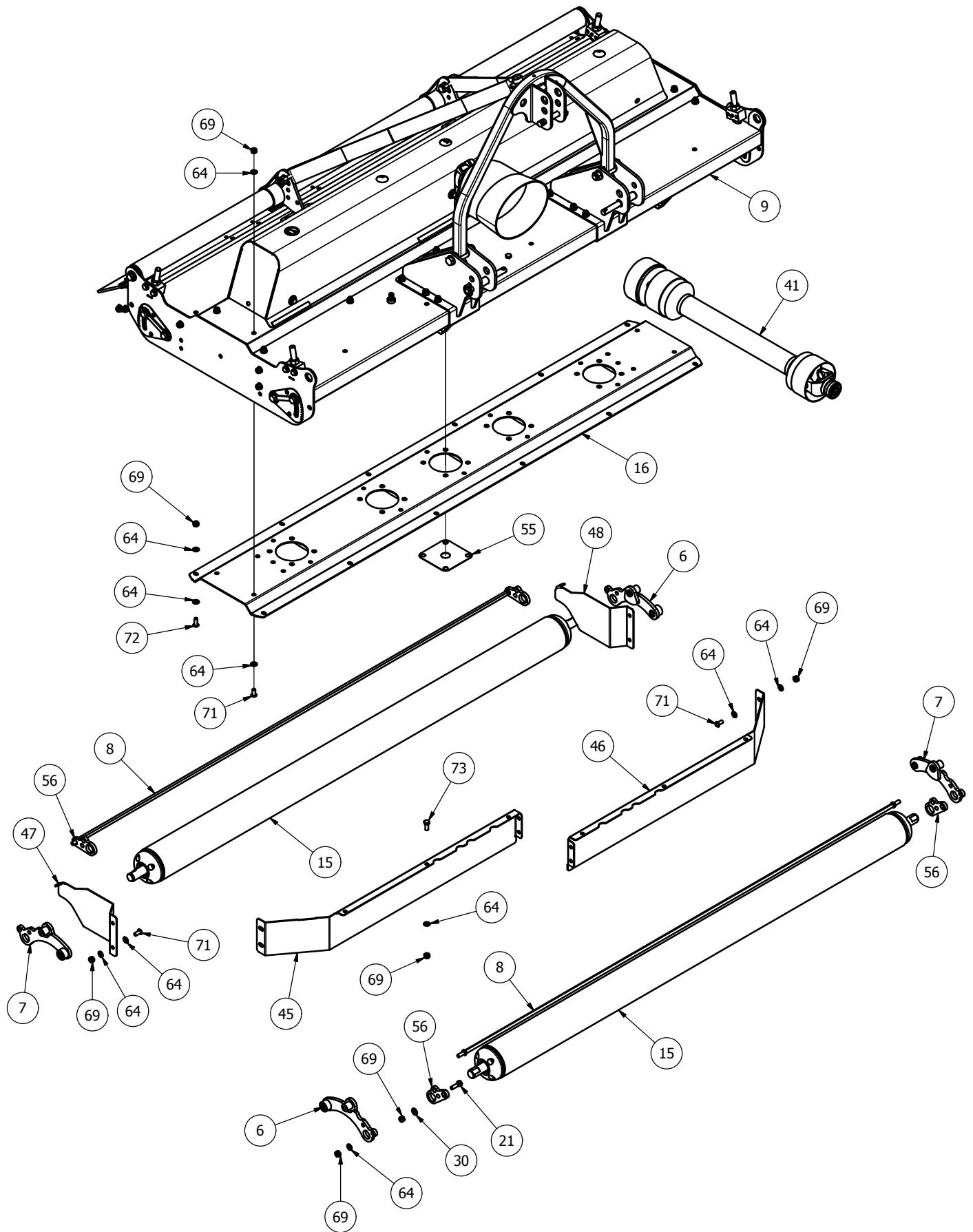



## MJ70-240 - Parts List

Item	Part No.	Description	Qty	Item	Part No.	Description	Qty
1	725-BLD-L	725 BLADE (Anti_Clk)	2	44	T27A-S1	T27A STUD	4
2	725-BLD-R	725 BLADE (Clk)	2	45	8400RM-AF03	AERO-FOIL (8400)	1
3	8400RM-CV14	GUARD BASE MOUNT	4	46	8400RM-AF03H	AERO-FOIL (8400)	1
4	8400RM-HG55	M20 ADJUSTER BLOCK	4	47	8400RM-GRD15	REAR DEFLECTOR	1
5	8400RM-HG65	M20 THREADED ADJUSTER	4	48	8400RM-GRD15H	REAR DEFLECTOR	1
6	8400RM-RPV01	ROLLER PIVOT	2	49	8400RM-HG03	HEIGHT INDICATOR	4
7	8400RM-RPV10	ROLLER PIVOT	2	50	8400RM-HG04	HEIGHT GUIDE	4
8	8400RM-SCRPR-01	8400 SCRAPER BAR	2	51	8400RM3-CV21	8400 REAR COVER	1
9	8400RM3-BD01	MJ70-240 BODY	1	52	8400RM3-CV23	RUBBER CLAMP	1
10	8400RM3-LM21	LINKAGE MOUNT	1	53	8400RM3-LM11	LINKAGE SUPPORT	2
11	8400RM3-LM21H	LINKAGE MOUNT	1	54	8400RM3-SM11	STRAP SUPPORT	1
12	8400RM3-SM01	STRAP MOUNT	2	55	MJ70-240-GBR21	CENTER BOX BLANK	1
13	8400RM3-TM01	8400 TUBE MOUNT	1	56	SCRPR-SQ12-01	SCRAPER MOUNT	4
14	GM84-55L	8400 DRIVE TUBE (LONG)	2	57	1/2F	1/2" FINE NYLOC NUT	28
15	GM84-ROL	8400 ROLLER	2	58	190.000.545	PTO GUARD (EXTENDED OVAL)	1
16	MJ70-240-GBR18	UNDERSIDE TROUGH	1	59	5/8F	5/8" FINE NYLOC NUT	20
17	12x112FSKS	1/2"x1 1/2" FINE SOCKET HEAD 12.9	24	60	58x2FBZP	5/8"x2" FINE BOLT	20
18	74	CAT 1 PIN DIA 19x102mm	1	61	851	GREASE NIPPLE M8x1.25 STR	8
19	DSR-1-2	1/2" RATED 'D' SHACKLE	2	62	AN099/10	LINCH PIN DIA 9.5	3
20	DSR-5-8	5/8" RATED 'D' SHACKLE	1	63	DSW34	DISC SPRING 34x16.3 x2	10
21	M12x40BZP	M12x40 BOLT	4	64	FWM12	M12 FLAT WASHER	126
22	S15707	CAT 1/2 LINK PIN	2	65	FWM12L	M12 FLAT WASHER (LARGE)	8
23	205872	6 SPLINE 'L' BOX RATIO 1.92	2	66	FWM16	M16 FLAT WASHER	20
24	205874	6 SPLINE 'T' BOX RATIO 1.92	2	67	FWM20	M20 FLAT WASHER	8
25	60CSD	60mm STAR DRIVE	2	68	FWM8	M8 FLAT WASHER	38
26	8400RM3-CV22	RUBBER FLAP	1	69	M12	M12 NYLOC NUT	75
27	8400RM3-CVR	8400 GEARBOX COVER MK3	1	70	M12x20SZP	M12x20 SET BOLT	8
28	8400STR	8400RM MKII STRAP (2000mm)	1	71	M12x25SKBH	M12x25 SOCKET BUTTON HEAD 10.9	21
29	CP176-181MG1	45mm INSERT	5	72	M12x30SKBH	M12x30 SOCKET BUTTON HEAD 10.9	30
30	D281215	DISC SPRING 28x12x1.5	4	73	M12x30SZP	M12x30 SET BOLT	8
31	G1106	BRASS TAP CONNECTOR	2	74	M12x35BZP	M12x35 BOLT	2
32	GM3	STANDARD A-FRAME	1	75	M12x40SKBH	M12x40 SOCKET BUTTON HEAD 10.9	2
33	GM84-DRV	6 SPLINE STAR DRIVE	4	76	M16x50SZP	M16x50 SET BOLT	8
34	I-257	3/4x1/2 REDUCER BUSH	2	77	M16x60BZP	M16x60 BOLT	2
35	LS002	ANTI VIBRATION RUBBER	7	78	M20	M20 NYLOC NUT	2
36	M12x100BZP	M12x100 BOLT	4	79	M20x120BZP	M20x120 BOLT	2
37	M12x50SZP	M12x50 SET BOLT	8	80	M8	M8 NYLOC NUT	30
38	M8x25SKBH	M8x25 SOCKET BUTTON HEAD 10.9	14	81	M8x16SKBH	M8x16 SOCKET BUTTON HEAD 10.9	20
39	NL16SP	M16 SP NORDLOCK	20	82	MJRC-113	113 PCD RUBBER COUPLING	4
40	T27A267245	6 SPLINE 'T' BOX RATIO 1.92	1	83	NL12SP	M12 SP NORDLOCK	20
41	T500810ENC12RW6	FIXED SLIP CLUTCH 1200 Nm	1				
42	8400RM3-TM04	TUBE MOUNT STUB	2				
43	2000CM-GBM01	CENTER BOX MOUNT	1				

## MJ70 Blades 725-BLD-L

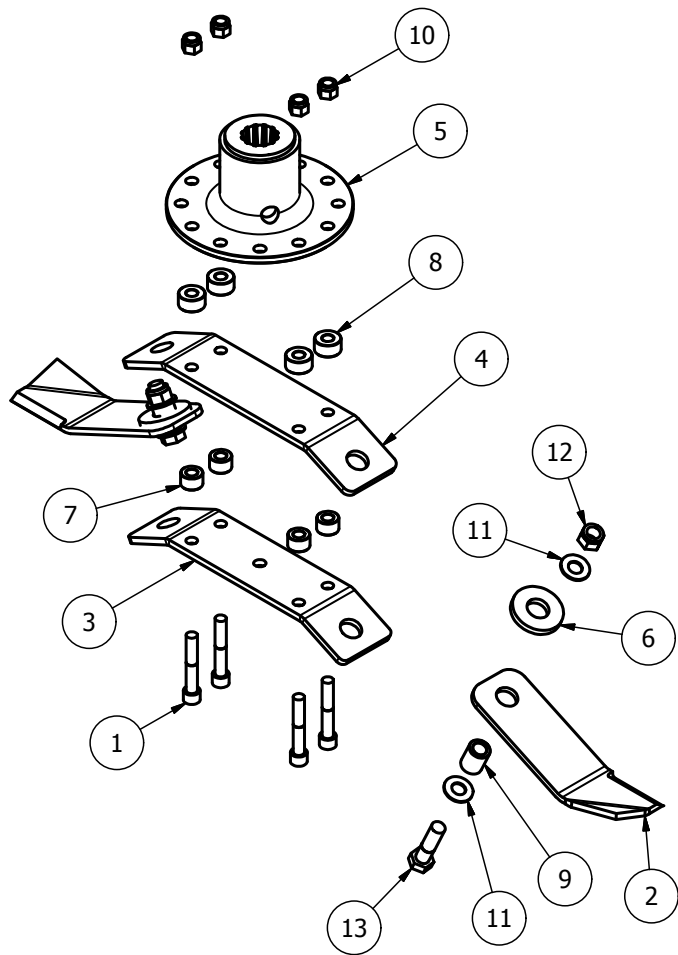

Item	Part No.	Description	Qty
1	12x3FSKS	1/2"x3" FINE SOCKET HEAD 12.9	4
2	BLD-25025-AC	BLADE 250xDia 25 (Anti-Clk)	2
3	BLDB-294-25	BLADE BACK (294 CTR 25 deg)	1
4	BLDB-315-25	BLADE BACK (315 CTR 25 deg)	1
5	DF-BMP	J205 G/BOX BLADE MOUNT	1
6	RM2-SP	BLADE SPACER PLATE	2
7	12T-BBS	BLADE BACK SPACER	4
8	84RM-BSB	BLADE SPACER BUSH	4
9	BB25-16-32	BLADE BUSH	2
10	1/2F	1/2" FINE NYLOC NUT	4
11	DSW34	DISC SPRING 34x16.3 x2	4
12	M16	M16 NYLOC NUT	2
13	M16x60BZP	M16x60 BOLT	2

## 725-BLD-R

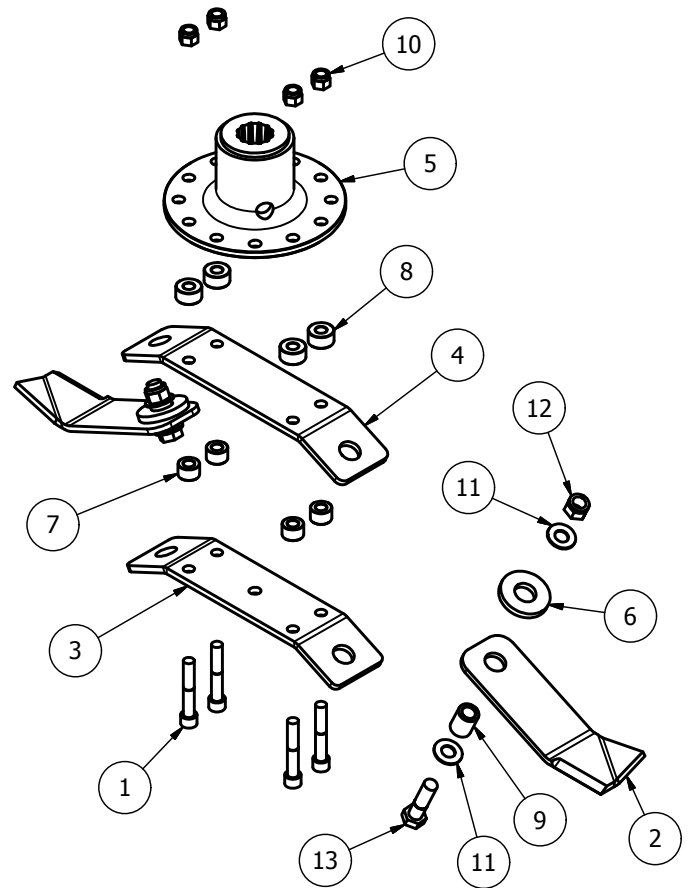

Item	Part No.	Description	Qty
1	12x3FSKS	1/2"x3" FINE SOCKET HEAD 12.9	4
2	BLD-25025-C	BLADE 250xDia 25 (Clk)	2
3	BLDB-294-25	BLADE BACK (294 CTR 25 deg)	1
4	BLDB-315-25	BLADE BACK (315 CTR 25 deg)	1
5	DF-BMP	J205 G/BOX BLADE MOUNT	1
6	RM2-SP	BLADE SPACER PLATE	2
7	12T-BBS	BLADE BACK SPACER	4
8	84RM-BSB	BLADE SPACER BUSH	4
9	BB25-16-32	BLADE BUSH	2
10	1/2F	1/2" FINE NYLOC NUT	4
11	DSW34	DISC SPRING 34x16.3 x2	4
12	M16	M16 NYLOC NUT	2
13	M16x60BZP	M16x60 BOLT	2

Warranty: This machine is guaranteed for 12 months. No warranty is given where the machine is being used as a hire machine. Warranty is against faulty workmanship or parts, with the exception of components not of MAJOR'S manufacture or design, i.e. hydraulic components, universally jointed shafts, chains and tyres, etc., which are subject to the original manufacturers conditions. To register your machine for warranty, please go to the support section of our website [www.major-equipment.com](http://www.major-equipment.com) and enter your details.

**MAJOR**  
WWW.MAJOR-EQUIPMENT.COM

The Grass & Slurry Machinery Specialists  
Agricultural ~ Professional Grounds care ~ Industrial

Home Products About Us Gallery Dealers News **Support** Contact Us

You are in: English >> Support

## Support

### Product Registration

Please click here to register your machine. We are committed to providing you with excellent products and product support. Please register your machine to ensure you get the correct warranty cover and service bulletins.

### Product Support

Please click here to access operator manuals.

### Dealer Support

Please click here for access to our dealer support area.

**Support**

- Product Registration
- Operator Manuals & Spare Parts Books
- Dealer Support
- Support Contact
- FAQ

follow us on facebook

#### Recent News

- ▶ 3100LGP With Raingun
- ▶ New Website Launch!
- ▶ Major Heads For Oz
- ▶ Visit Our Facebook Page
- ▶ 2012 Shows

**MAJOR**  
WWW.MAJOR-EQUIPMENT.COM

**Head Office:**  
Ballyhaunis, Co. Mayo  
Ireland  
Tel: + 353 (0) 949630572  
[info@major-equipment.com](mailto:info@major-equipment.com)

**UK Office:**  
Major Ind. Estate, Heysham  
Lancs, LA3 3JJ  
Tel: + 44 (0) 1524 850501  
[ukinfo@major-equipment.com](mailto:ukinfo@major-equipment.com)

**Nederland (& Deutschland):**  
Postbus 29, NL-7700 AA Dedemsvaart  
Nederland  
Tel: + 31 (0) 6389 19585  
[euinfo@major-equipment.com](mailto:euinfo@major-equipment.com)



**HEAD OFFICE**

**Major Equipment Intl Ltd**  
Ballyhaunis, Co Mayo  
Ireland  
Tel: +353 (0) 9496 30572

**UK OFFICE**

**Major Equipment Ltd**  
Major Ind. Estate, Heysham,  
Lancs, LA3 3JJ, UK  
Tel: +44 (0) 1524 850501

**Netherlands & Germany OFFICE**

**Major Equipment Intl Ltd**  
Postbus 29, NL-7700 AA  
Dedemsvaart, Nederland  
Tel: + 31 (0) 6389 19585