

Operating manual

AMAZONE

GROUNDKEEPER

GHL, GHL-T SMARTCUT



MG5075
BAF0006.2 05.17
Printed in France

Please read and follow this operating manual before putting the machine into operation. Keep it in a safe place for future use.

en



READING THE INSTRUCTION

manual and adhering to it should not appear to be inconvenient and superfluous as it is not enough to hear from others and to realise that a machine is good, to buy it and to believe that now everything should work by itself. The person concerned would not only harm himself but also make the mistake of blaming the machine for the reason of a possible failure instead of himself. In order to ensure good success one should go into the mind of a thing, make himself familiar with every part of the machine and to get acquainted with its handling. Only in this way would you be satisfied both with the machine as also with yourself. To achieve this is the purpose of this instruction manual.

Leipzig-Plagwitz 1872. Rud. Sark.



Identification data

Enter the machine identification data here. You will find the identification data on the rating plate.

Machine identification number:
(ten-digit)

Type:

Groundkeeper GHL; GHL-T
SMARTCUT

Year of manufacture:

Empty weight kg:

Approved total weight (kg):

Maximum load (kg):

Manufacturer's address

AMAZONE S.A. FORBACH

17, rue de la Verrerie

BP 90106

F-57602 Forbach, France

Phone: +33 (0) 3 87 84 65 70

Fax: +33 (0) 3 87 84 65 71

E-mail: forbach@amazone.fr

Spare part orders

Spare parts lists are freely accessible in the spare parts portal at www.amazone.de.

Please send orders to your AMAZONE dealer.

Formalities of the operating manual

Document number: MG5075

Compilation date: 02.14

© Copyright AMAZONE S.A. FORBACH, 2014

All rights reserved.

Reprinting, even of extracts, is only permitted with the approval of AMAZONE S.A. FORBACH.



Foreword

Foreword

Dear Customer,

You have chosen one of the quality products from our wide range of AMAZONE agricultural machinery. We thank you for your confidence in our products.

On receiving the machine, check to see if it was damaged during transport or if parts are missing. Using the delivery note, check that the machine was delivered in full including the ordered special equipment. Replacement will be made only if a claim is filed immediately!

Please read and follow this operating manual—in particular, the safety instructions—before putting the machine into operation. Only after careful reading will you be able to benefit from the full scope of your newly purchased machine.

Please ensure that all the machine operators have read this operating manual before they put the machine into operation.

Should you have any questions or problems, please consult this operating manual or contact your local service partner.

Regular maintenance and timely replacement of worn or damaged parts increases the lifespan of your machine.

User evaluation

Dear Reader

We update our operating manuals regularly. Your suggestions for improvement help us to create ever more user-friendly manuals. Please send your suggestions to:

AMAZONE S.A. FORBACH

17, rue de la Verrerie

BP 90106

F-57602 Forbach, France

Phone: +33 (0) 3 87 84 65 70

Fax: +33 (0) 3 87 84 65 71

E-mail: forbach@amazone.fr



1	User information	7
1.1	Purpose of the document.....	7
1.2	Locations in the operating manual	7
1.3	Diagrams used	7
2	General safety instructions.....	8
2.1	Obligations and liability	8
2.2	Representation of safety symbols.....	10
2.3	Organisational measures	11
2.4	Safety and protection equipment	11
2.5	Informal safety measures.....	11
2.6	User training.....	12
2.7	Safety measures in normal operation	13
2.8	Dangers from residual energy.....	13
2.9	Maintenance and repair work, fault elimination	13
2.10	Constructive changes	13
2.10.1	Spare and wear parts and aids	14
2.11	Cleaning and disposal.....	14
2.12	User workstation	14
2.13	Warning symbols and other signs on the machine	15
2.13.1	Positioning of warning symbols and other labels.....	23
2.14	Dangers if the safety information is not observed.....	25
2.15	Safety-conscious working	25
2.16	Safety information for users.....	26
2.16.1	General safety and accident prevention information	26
2.16.2	Hydraulic system.....	29
2.16.3	Electrical system	30
3	General description of the machine.....	30
3.1	Areas of application	30
3.2	Declaration of conformity	30
3.3	Details required for enquiries	30
3.4	Identification of the machine	31
3.5	Technical data.....	31
3.5.1	Noise production data	32
3.6	Intended use	32
4	Taking delivery of the machine	33
5	Attaching and detaching the machine to/from the tractor	33
5.1	Machine type GHL	33
5.2	PTO shaft.....	36
5.3	Fitting and adjusting the PTO shaft	36
5.3.1	Fitting the PTO shaft.....	36
5.3.2	Adjusting the PTO shaft when first attached.....	36
5.4	Groundkeeper transmission input speed	38
5.5	Connecting the hydraulics.....	39
6	The mower unit	41
6.1	Fitting the mowing and scarifying tools.....	41
6.2	Mowing.....	45
6.3	Scarifying	46
6.4	Mulching.....	48
6.5	Collecting	48
6.6	Emptying the catcher	49



Table of Contents

7	Adjusting the cutting height.....	50
7.1	Front roller	52
8	Cleaning the machine	53
9	Maintenance and care.....	54
9.1	Oil level in the angular gearbox.....	54
9.2	Lubrication points	54
9.3	Extended periods of downtime.....	56
9.4	Tyre pressure	56
10	Additional operating instructions for the towed AMAZONE GHL-T Lift Groundkeeper.....	57
10.1	Attaching and detaching the machine.....	57
10.1.1	Hydraulic connections	57
10.1.2	Three-point attachment	58
10.2	Transport on public roads	60
10.2.1	Rear guide wheel vibration damping.....	61
10.3	Machine in working use.....	63
10.3.1	Mowing and scarifying.....	63
10.3.2	Emptying the catcher.....	63
10.4	After use – uncoupling the machine.....	63
10.5	Maintenance.....	64
10.5.1	Tyre pressure	64
10.5.2	Additional lubrication point	65



1 User information

The "User information" section supplies information on using the operating manual.

1.1 Purpose of the document

This operating manual

- Describes the operation and maintenance of the machine.
- Provides important information on safe and efficient handling of the machine.
- Is a component part of the machine and should always be kept with the machine or the traction vehicle.
- Keep it in a safe place for future use.

1.2 Locations in the operating manual

All the directions specified in the operating manual are always viewed in the direction of travel.

1.3 Diagrams used

Instructions for action and reactions

Tasks to be carried out by the user are presented as numbered instructions. Always keep to the order of the instructions. The reaction to instructions is given by an arrow.

Example:

1. Instruction for action 1
→ Reaction of the machine to instruction for action 1
2. Instruction for action 2

Lists

Lists without a mandatory sequence are presented as a list with bullet points.

Example:

- Point 1
- Point 2

Item numbers in diagrams

Numbers in round brackets refer to the item numbers in the diagrams. The first digit refers to the diagram; the second digit, to the item number in the illustration.

Example (Fig. 3/6)

- Figure 3
- Item 6



2 General safety instructions

This section contains important information on safe operation of the machine.

2.1 Obligations and liability

Comply with the instructions in the operating manual

Knowledge of the basic safety information and safety regulations is a basic requirement for safe handling and fault-free machine operation.

Obligations of the operator

The operator is obliged only to let those people work with/on the machine who

- Are aware of the basic workplace safety information and accident prevention regulations.
- Have been trained in working with/on the machine.
- Have read and understood this operating manual.

The operator is obliged

- To keep all the warning symbols on the machine in a legible state.
- To replace damaged warning symbols.

If you still have queries, please contact the manufacturer.

Obligations of the user

Before starting work, anyone charged with working with/on the machine is obliged

- To comply with the basic workplace safety instructions and accident prevention regulations.
- To read and understand the section "General safety information" of this operating manual.
- To read the section "Warning symbols and other labels on the machine" (page 15) of this operating manual and to follow the safety instructions represented by the warning symbols when operating the machine.
- To get to know the machine.
- To read the sections of this operating manual, important for carrying out your work.

If the user discovers that a function is not working properly, then they must eliminate this fault immediately. If this is not the task of the user or if the user does not possess the appropriate technical knowledge, then they should report this fault to their superior (operator).



Risks in handling the machine

The machine has been constructed to the state-of-the art and the recognised rules of safety. However, there may be risks and restrictions which occur when operating the machine

- For the health and safety of the user or third persons,
- For the machine,
- For other goods.

Only use the machine

- For the purpose for which it was intended.
- In a perfect state of repair.

Eliminate any faults that could impair safety immediately.

Guarantee and liability

Our "General conditions of sales and business" are always applicable. These shall be available to the operator, at the latest on the completion of the contract. Guarantee and liability claims for damage to people or goods will be excluded if they can be traced back to one or more of the following causes:

- Improper use of the machine.
- Improper installation, commissioning, operation and maintenance of the machine.
- Operation of the machine with defective safety equipment or improperly attached or non-functioning safety equipment.
- Non-compliance with the instructions in the operating manual regarding commissioning, operation and maintenance.
- Independently-executed construction changes to the machine.
- Insufficient monitoring of machine parts that are subject to wear.
- Improperly executed repairs.
- Catastrophic events as a result of the impact of foreign objects or force majeure.

2.2 Representation of safety symbols

Safety instructions are indicated by the triangular safety symbol and the highlighted signal word. The signal word (DANGER, WARNING, CAUTION) describes the gravity of the risk and has the following significance:



DANGER

Indicates an immediate high risk, which will result in death or extremely serious physical injury (loss of body parts or long term damage) if not avoided.

If the instructions are not followed, then this will result in immediate death or serious physical injury.



WARNING

Indicates a medium risk, which could result in death or (extremely serious) physical injury if not avoided.

If the instructions are not followed, then this may result in death or serious physical injury.



CAUTION

Indicates a low risk, which could incur minor or medium level physical injury or damage to property if not avoided.



IMPORTANT

Indicates an obligation to special behaviour or an activity required for proper machine handling.

Non-compliance with these instructions can cause faults on the machine or in the environment.



NOTE

Indicates handling tips and particularly useful information.

These instructions will help you to use all the functions of your machine to the optimum.



2.3 Organisational measures

The operator must provide the necessary personal protective equipment, such as:

- Protective glasses
- Protective shoes
- Protective suit
- Skin protection, etc.



The operation manual

- Must always be kept at the place at which the machine is operated.
- Must always be easily accessible for the user and maintenance personnel.

Check all the available safety equipment regularly.

2.4 Safety and protection equipment

Before each commissioning of the machine, all the safety and protection equipment must be properly attached and fully functional. Check all the safety and protection equipment regularly.

Faulty safety equipment

Faulty or disassembled safety and protection equipment can lead to dangerous situations.

2.5 Informal safety measures

As well as all the safety information in this operating manual, comply with the general, national regulations pertaining to accident prevention and environmental protection.

When driving on public roads and routes, then you should comply with the statutory road traffic regulations.



2.6 User training

Only those people who have been trained and instructed may work with/on the machine. The operator must clearly specify the responsibilities of the people charged with operation, maintenance and repair work.

People being trained may only work with/on the machine under the supervision of an experienced person.

Activity \ People	Person specially trained for the activity ¹⁾	Trained person ²⁾	Person with specialist training (specialist workshop) ³⁾
Loading/Transport	X	X	X
Commissioning	--	X	--
Set-up, tool installation	--	--	X
Operation	--	X	--
Maintenance	--	--	X
Troubleshooting and fault elimination	--	X	X
Disposal	X	--	--

Legend: X..permitted --..not permitted

- 1) A person who can assume a specific task and who can carry out this task for an appropriately qualified company.
- 2) Instructed persons are those who have been instructed in their assigned tasks and in the possible risks in the case of improper behaviour, have been trained if necessary, and have been informed about the necessary protective equipment and measures.
- 3) People with specialist technical training shall be considered as a specialist. Due to their specialist training and their knowledge of the appropriate regulations, they can evaluate the work with which they have been charged and detect possible dangers.

Comment:

A qualification equivalent to specialist training can be obtained through long term activity in the appropriate field of work.



Only a specialist workshop may carry out maintenance and repair work on the machine, if such work is specifically designated "Workshop work". The personnel of a specialist workshop shall possess the appropriate knowledge and suitable aids (tools, lifting and support equipment) for carrying out the maintenance and repair work on the machine in a way which is both appropriate and safe.



2.7 Safety measures in normal operation

Only operate the machine if all the safety and protection equipment is fully functional.

Check the machine at least once a day for visible damage and check the function of the safety and protection equipment.

2.8 Dangers from residual energy

Note that there may be residual mechanical, hydraulic, pneumatic and electrical/electronic energy at the machine.

Use appropriate measures to inform the operating personnel. You can find detailed information in the relevant sections of this operating manual.

2.9 Maintenance and repair work, fault elimination

Carry out prescribed setting, maintenance and inspection work in a timely manner.

Secure all media such as compressed air and the hydraulic system against unintentional start-up.

Carefully fix and secure larger subassemblies to lifting gear when carrying out replacement work.

Check all the screw connections for a firm seat. On completing maintenance work, check the function of safety and protection equipment.

2.10 Constructive changes

You may make no changes, expansions or modifications to the machine without the authorisation of AMAZONEN-WERKE. This is also valid when welding support parts.

Any expansion or modification work shall require the written approval of AMAZONEN-WERKE. Only use the modification and accessory parts released by AMAZONEN-WERKE so that the operating permit, for example, remains valid in accordance with national and international regulations.

Vehicles with an official type approval or with equipment connected to a vehicle with a valid type approval or approval for road transport according to the German road traffic regulations must be in the state specified by the approval.



WARNING

Risk of being crushed, cut, caught, drawn in or struck if supporting parts break.

It is forbidden to:

- Drill holes in the frame or on the chassis.
- Increasing the size of existing holes on the frame or the chassis.
- Welding support parts.



2.10.1 Spare and wear parts and aids

Immediately replace any machine parts which are not in a perfect state.

Use only genuine **AMAZONE** spare and wear parts or the parts cleared by AMAZONEN-WERKE so that the operating permit retains its validity in accordance with national and international regulations. If you use wear and spare parts from third parties, there is no guarantee that they have been designed and manufactured in such a way as to meet the requirements placed on them.

AMAZONEN-WERKE accepts no liability for damage arising from the use of unapproved spare parts, wear parts or auxiliary materials.

2.11 Cleaning and disposal

Handle and dispose of any materials used carefully, in particular:

- When carrying out work on lubrication systems and equipment and
- When cleaning using solvents.

2.12 User workstation

The machine may be operated by only one person sitting in the driver's seat of the tractor.



2.13 Warning symbols and other signs on the machine



Always keep all the warning symbols of the machine clean and in a legible state. Replace illegible warning symbols. You can obtain the warning symbols from your dealer using the order number (e.g. MD 075).

Warning symbols - structure

Warning symbols indicate dangers on the machine and warn against residual dangers. At these points, there are permanent or unexpected dangers.

A warning symbol consists of two fields:



Field 1

is a symbol describing the danger, surrounded by triangular safety symbol.

Field 2

is a symbol showing how to avoid the danger.

Warning symbols - explanation

The column **Order number and explanation** provides an explanation of the neighbouring warning symbol. The description of the warning symbols is always the same and specifies, in the following order:

1. A description of the danger.
For example: danger of cutting!
2. The consequence of non observance of the danger protection instructions.
For example: causes serious injuries to fingers or hands.
3. Instructions for avoiding the danger.
For example: only touch machine parts when they have come to a complete standstill.

General safety instructions

Order number and explanation

Warning symbols

MD 075

Risk of fingers and hands being cut or severed by rotating machine parts.

This hazard can cause extremely serious injuries with the loss of body parts such as fingers or hands.

Never reach into the danger area when the tractor engine is running with PTO shaft/hydraulic system connected.

Do not touch machine parts until they have come to a complete standstill.



MD 076

Risk of hands or arms being drawn in or caught by power-driven, unprotected chain or belt drives.

This hazard can cause extremely serious injuries, including loss of parts of the body from hands or arms.

Never open or remove protective equipment from chains or belt drives,

- while the tractor engine is running and the PTO shaft is connected/hydraulic drive is engaged
- or the ground wheel drive is in motion

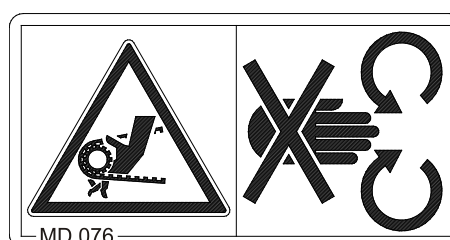

MD 078

Risk of fingers or hands being crushed by accessible moving machine parts.

This hazard can cause extremely serious injuries with the loss of body parts such as fingers or hands.

Never reach into the danger area when the tractor engine is running with the PTO shaft/hydraulic system connected.



MD 079

Hazard from materials or foreign objects that are thrown from or ejected by the machine.

This hazard can cause extremely serious injuries to any part of the body.

Ensure that persons not involved in the operation of the machine maintain a sufficient safety distance from the danger area created by the machine while the tractor engine is running.

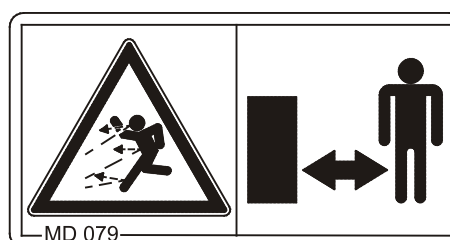



MD 081

Risk of any part of the body being crushed by machine parts descending unintentionally, having been raised via the lifting cylinder .

This danger will cause serious injuries anywhere on the body or death.

If machine parts have been raised, secure the lifting cylinder against lowering unintentionally, before entering the danger area beneath the raised machine parts.

To do this, use the mechanical lifting cylinder support or the hydraulic locking device.

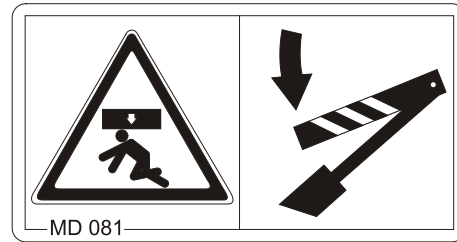

MD 086

Risk of any part of the body being crushed beneath raised machine parts if they descend unintentionally.

This hazard can cause serious injuries to any part of the body, or even death.

Before spending time in the danger area underneath raised machine parts, secure the raised parts against descending unintentionally.

To do this, use the mechanical support or the hydraulic locking device.

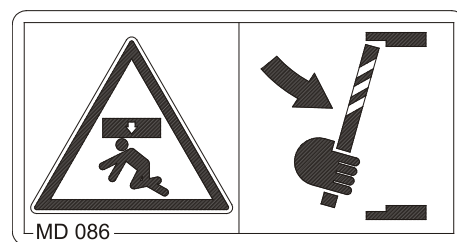

MD 087

Risk of toes or feet being cut or severed by power-driven tools.

This hazard can cause serious injuries, including loss of parts of the body from toes or feet.

Maintain a sufficient safety distance from the danger area while the tractor engine is running and the PTO shaft/hydraulic system is connected.

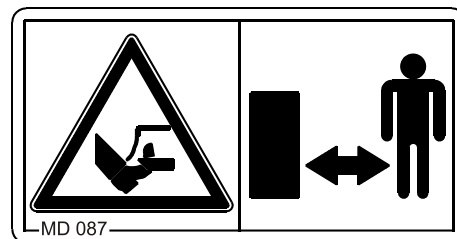

General safety instructions

MD 089

Danger

Risk of any part of the body being crushed in the danger area beneath suspended loads/machine parts.

This danger will cause serious injuries anywhere on the body or death.

The presence of persons under suspended loads/machine parts is prohibited.

Maintain a sufficient safety distance from suspended loads/machine parts.

Ensure that all persons present maintain a sufficient safety distance from suspended loads/machine parts.

Direct persons out of the danger area created by suspended loads/machine parts.

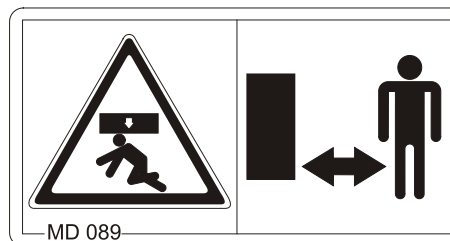

MD 095

Read and understand the operating manual safety information before starting up the machine!



MD 096

Danger of infection to the whole body from liquids escaping at a high pressure (hydraulic fluid)!

This danger will cause serious injuries over the whole body, if hydraulic fluid escaping at high pressure passes through the skin and into the body.

Never attempt to plug leaks in hydraulic lines using your hand or fingers.

Read and understand the information in the operating manual before carrying out maintenance and repair work.

If you are injured by hydraulic fluid, contact a doctor immediately.

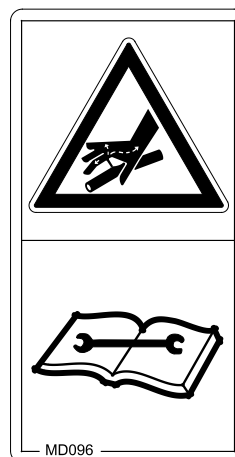



MD 097

Risk of any part of the body being crushed due to standing in the stroke area of the three-point suspension when the three-point hydraulics are operated.

This hazard can cause extremely serious and potentially fatal injuries.

- Personnel are prohibited from standing in the stroke area of the three-point suspension when the three-point hydraulics are operated.
- Actuate the operating controls for the tractor's three-point hydraulic system
 - only from the designated workstation,
 - never from a location in the stroke area between tractor and machine.



MD 100

This symbol indicates lashing points for fastening slinging gear when loading the machine.

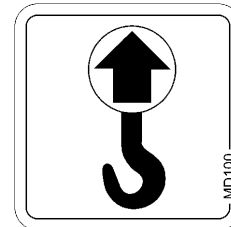

MD 102

Danger from unintentional machine starting and rolling during intervention in the machine, e.g. installation, adjusting, troubleshooting, cleaning, maintaining and repairing.

This hazard can cause extremely serious injuries anywhere on the body, or even death.

- Secure the tractor and the machine against unintentional start-up and rolling before any intervention in the machine.
- Depending on the type of intervention, read and understand the information in the relevant sections of the operating manual.

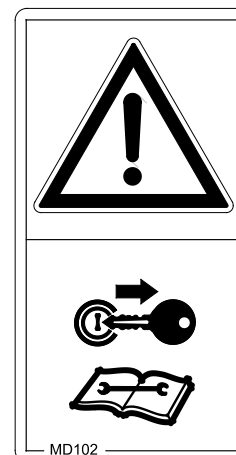

General safety instructions

MD 104

Risk of any part of the body being crushed or struck due to standing within the swivel range of machine parts which move laterally.

These dangers can cause extremely serious and potentially fatal injuries.

- Maintain an adequate safety distance from moving machine parts while the tractor engine is running.
- Ensure that persons present maintain a sufficient safety distance from moving machine parts.

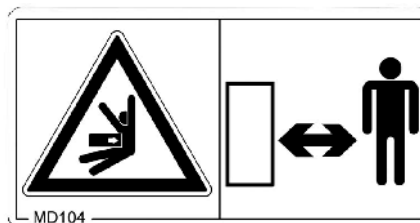

MD 113

Study and observe the instructions for cleaning, servicing and maintaining in the appropriate chapter of the operating manual.

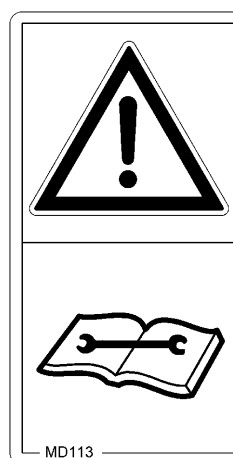

MD 114

This symbol indicates a lubrication point

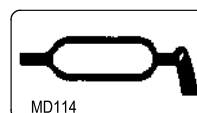

MD 115

The maximum operating pressure of the hydraulic system is 200 bar.

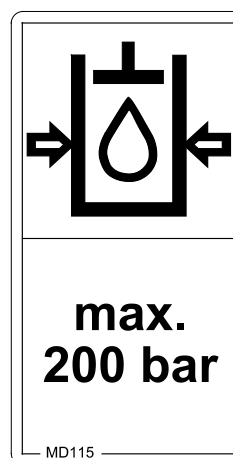



MD 118

This symbol indicates the maximum drive speed (540 rpm) and direction of rotation of the drive shaft on the machine side.

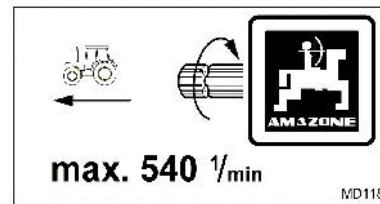

MD 145

The CE mark signifies that the machine complies with basic health and safety requirements.



MD 150

Risk of fingers and hands being cut or severed by rotating, unprotected, sharp-edged machine parts.

This danger causes extremely serious injuries with the loss of body parts such as fingers or hands.

Never open or remove guard devices from rotating, sharp-edged machine parts while the tractor engine is running with the PTO shaft connected/hydraulic drive engaged.

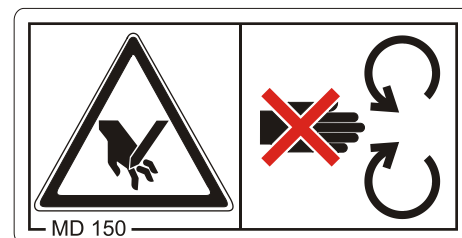

MD 170

Risk of being crushed, drawn in or caught by unprotected, moving machine parts as a result of missing safety devices.

This hazard can cause extremely serious injuries, including the loss of body parts.

Close protective equipment which has been opened or refit protective equipment which has been removed before you start the machine.

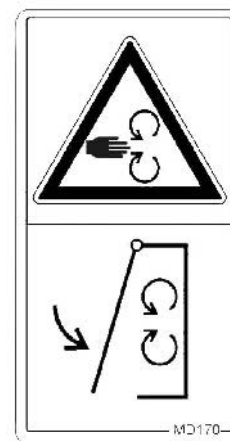

MD 171

Risk of any part of the body being crushed, as a result of standing in the tipping area when the loading bed has been raised.

This hazard can cause extremely serious and potentially fatal injuries.

- It is prohibited to stand in the tipping area when the loading bed has been raised.
- Instruct people to leave the tipping area of the machine before raising the loading bed.





2.13.1 Positioning of warning symbols and other labels

Warning symbols

The following diagrams show the arrangement of the warning symbols on the machine.

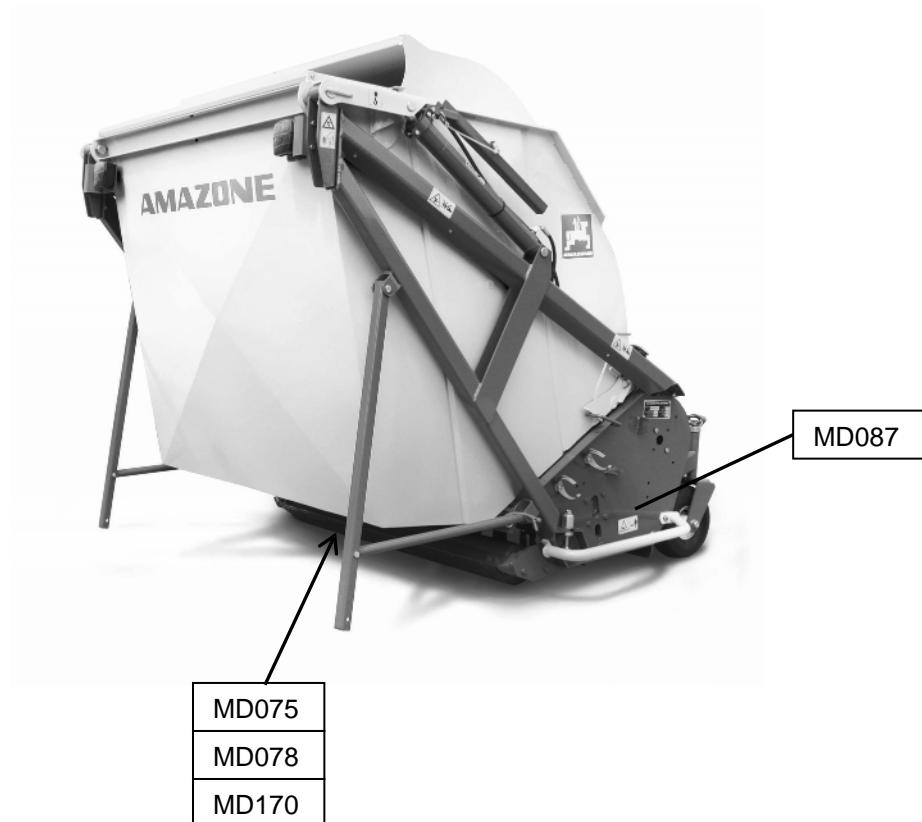
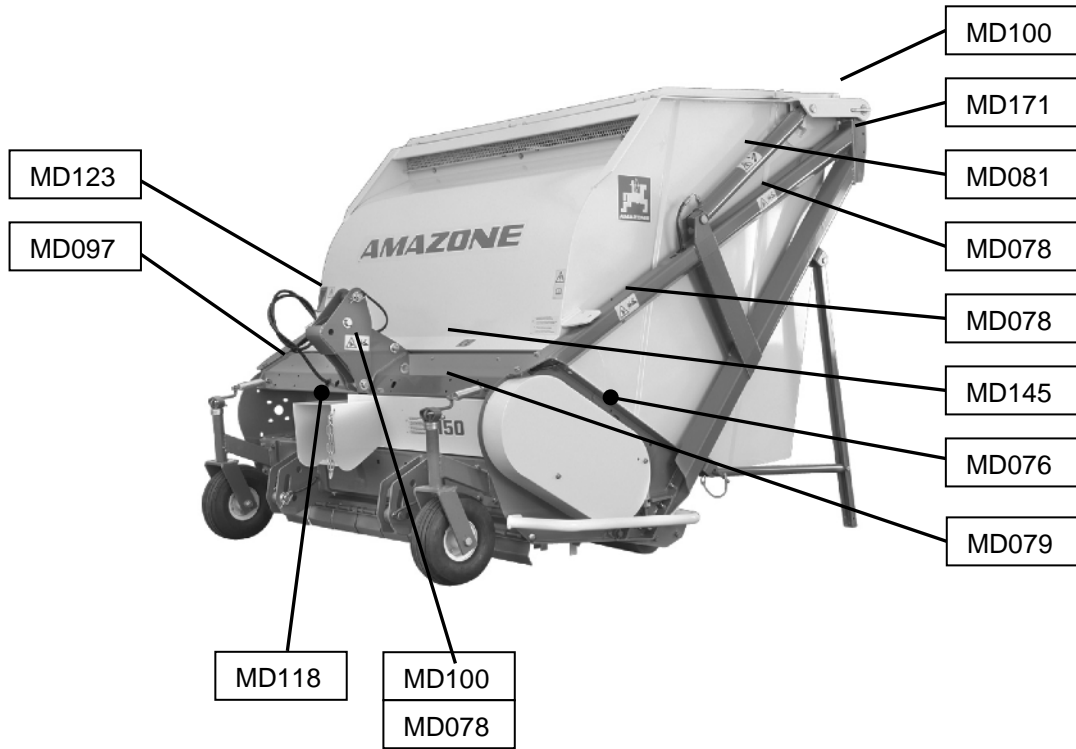



General safety instructions

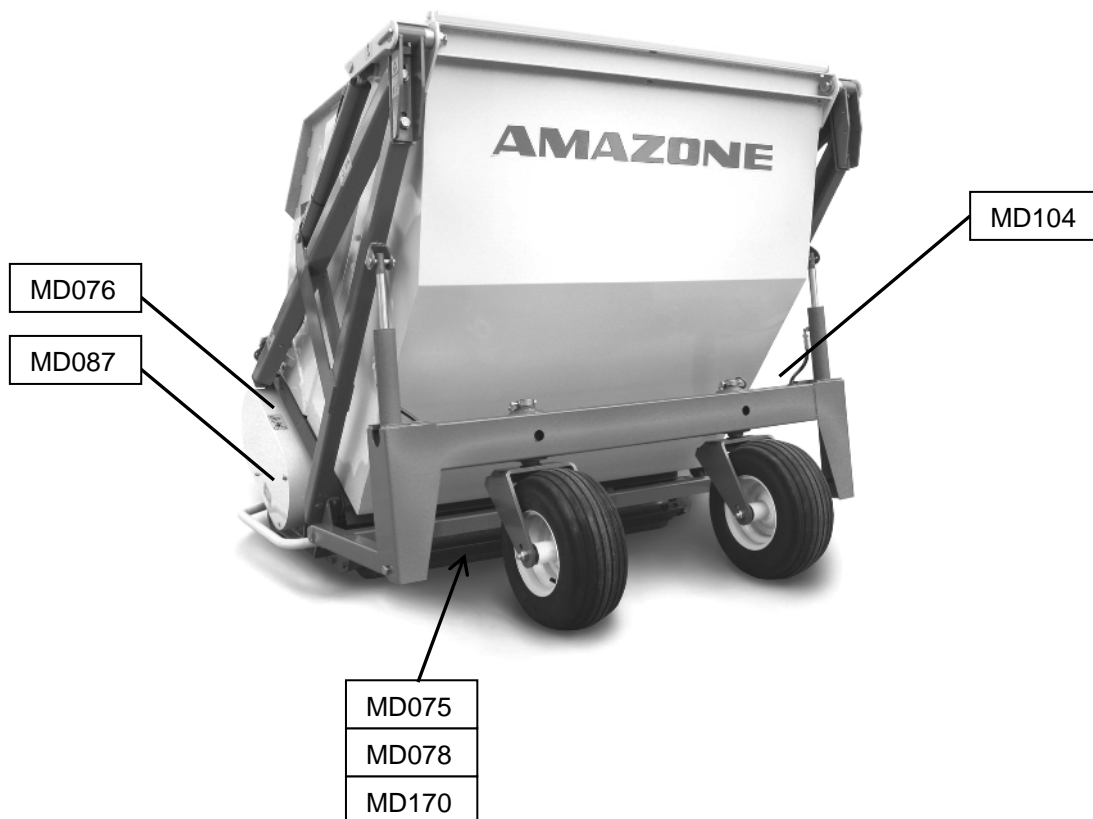
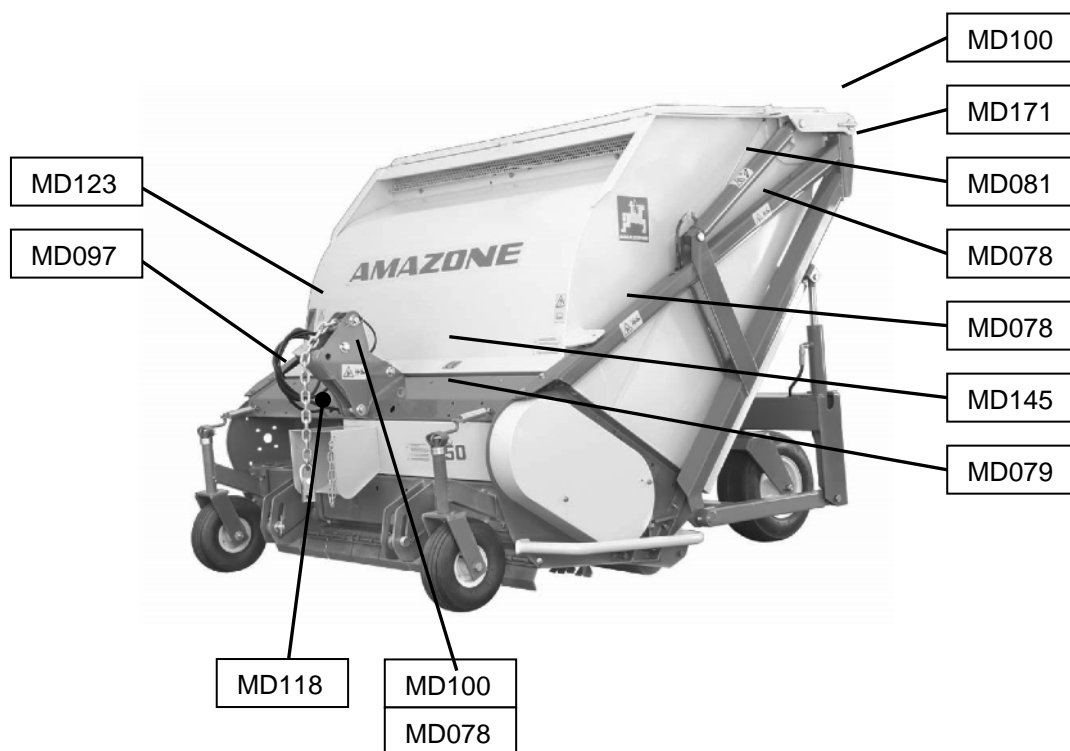



2.14 Dangers if the safety information is not observed

Non observance of the safety information

- Can pose both a danger to people and also to the environment and machine.
- Can lead to the loss of all warranty claims.

Seen individually, non-compliance with the safety information could pose the following risks:

- Danger to people through non-secured working areas.
- Failure of important machine functions.
- Failure of prescribed methods of maintenance and repair.
- Danger to people through mechanical and chemical impacts.
- Risk to environment through leakage of hydraulic fluid.

2.15 Safety-conscious working

Besides the safety information in this operating manual, the national general workplace safety and accident prevention regulations are binding.

Comply with the accident prevention instructions on the warning symbols.

When driving on public roads and routes, comply with the appropriate statutory road traffic regulations.

2.16 Safety information for users



WARNING

Risk of being crushed, cut, caught, drawn in or struck due to insufficient traffic and operational safety!

Before starting up the machine and the tractor, always check their traffic and operational safety.

2.16.1 General safety and accident prevention information

- Beside these instructions, comply with the general valid national safety and accident prevention regulations.
- The warning symbols and labels attached to the machine provide important information on safe machine operation. Compliance with this information guarantees your safety!
- Before moving off and starting up the machine, check the immediate area of the machine (children)! Ensure that you can see clearly!
- It is forbidden to ride on the machine or use it as a means of transport!
- Drive in such a way that you always have full control over the tractor with the attached machine.

In so doing, take your personal abilities into account, as well as the road, traffic, visibility and weather conditions, the driving characteristics of the tractor and the connected machine.

Connecting and disconnecting the machine

- Only connect and transport the machine with tractors suitable for the task.
- When connecting machines to the tractor three-point hydraulic system, the attachment categories of the tractor and the machine must always be the same!
- Connect the machine to the prescribed equipment in accordance with the specifications.
- When coupling machines to the front or the rear of the tractor, the following may not be exceeded:
 - The approved total tractor weight
 - The approved tractor axle loads
 - The approved load capacities of the tractor tyres
- Secure the tractor and the machine against unintentional rolling, before coupling or uncoupling the machine.
- It is forbidden for people to stand between the machine to be coupled and the tractor, whilst the tractor is moving towards the machine!
Any helpers may only act as guides standing next to the vehicles, and may only move between the vehicles when both are at a standstill.
- Secure the operating lever of the tractor hydraulic system so that unintentional raising or lowering is impossible, before connecting the machine to or disconnecting the machine from the tractor's



three-point hydraulic system.

- When coupling and uncoupling machines, move the support equipment (if available) to the appropriate position (stability).
- When actuating the support equipment, there is a risk of injury from nip and shear points.
- Be particularly careful when coupling the machine to the tractor or uncoupling it from the tractor! There are nip and shear points in the area of the coupling point between the tractor and the machine.
- It is forbidden to stand between the tractor and the machine when actuating the three-point hydraulic system.
- Coupled supply lines:
 - Must give without tension, bending or rubbing on all movements when travelling round corners.
 - May not scour other parts.
- The release ropes for quick action couplings must hang loosely and may not release themselves when lowered.
- Also ensure that uncoupled machines are stable!

Use of the machine

- Before starting work, ensure that you understand all the equipment and actuation elements of the machine and their function. There is no time for this when the machine is already in operation!
- Do not wear loose-fitting clothing! Loose clothing increases the risk over being caught by drive shafts!
- Only start-up the machine, when all the safety equipment has been attached and is in the safety position!
- Comply with the maximum load of the connected machine and the approved axle and support loads of the tractor. If necessary, drive only with a partially-filled hopper.
- It is forbidden to stand in the working area of the machine.
- It is forbidden to stand in the turning and rotation area of the machine.
- There are contusion and cutting points at externally-actuated (e.g. hydraulic) machine points.
- Only actuate externally-actuated machine parts when you are sure that there is no-one within a sufficient distance from the machine!
- Secure the tractor against unintentional start-up and rolling before you leave the tractor.
For this:
 - Lower the machine onto the ground
 - Apply the parking brake
 - Switch off the tractor engine
 - Remove the ignition key



Machine transportation

- When using public highways, national road traffic regulations must be observed.
- Before moving off, check:
 - the correct connection of the supply lines
 - the lighting system for damage, function and cleanliness
- Ensure that the tractor has sufficient steering and braking power. Any machines and front/rear weights connected to the tractor influence the driving behaviour and the steering and braking power of the tractor.
- If necessary, use front weights.
The front tractor axle must always be loaded with at least 20 % of the empty tractor weight, in order to ensure sufficient steering power.
- Always fix the front or rear weights to the intended fixing points according to regulations.
- Comply with the maximum load of the connected machine and the approved axle and support loads of the tractor.
- The tractor must guarantee the prescribed brake delay for the loaded vehicle combination (tractor plus connected machine).
- Check the brake power before moving off.
- When turning corners with the machine connected, take the broad load and balance weight of the machine into account.
- Before moving off, ensure sufficient side locking of the tractor lower links, when the machine is fixed to the three-point hydraulic system or lower links of the tractor.
- Before moving off, move all the swivel machine parts to the transport position.
- Before moving off, secure the operating lever of the three-point hydraulic system against unintentional raising or lowering of the connected machine.
- Check that the transport equipment, e.g. lighting, warning equipment and protective equipment, is correctly mounted on the machine.
- Before transportation, carry out a visual check that the upper and lower link pins are firmly fixed with the lynch pin against unintentional release.
- Adjust your driving speed to the prevailing conditions.
- Before driving downhill, switch to a low gear.
- Before moving off, always switch off the independent wheel braking (lock the pedals).



2.16.2 Hydraulic system

- The hydraulic system is under a high pressure.
- Ensure that the hydraulic hose lines are connected correctly.
- When connecting the hydraulic hose lines, ensure that the hydraulic system is unpressurised on both the machine and tractor sides.
- It is forbidden to block the operator controls on the tractor which are used for hydraulic and electrical movements of components, e.g. folding, swivelling and pushing movements. The movement must stop automatically when you release the appropriate control. This does not apply to equipment movements that:
 - are continuous or
 - are automatically locked or
 - necessarily require an open centre or pressure position to operate correctly
- Before working on the hydraulic system
 - Lower the machine
 - Depressurise the hydraulic system
 - Switch off the tractor engine
 - Apply the parking brake
 - Take out the ignition key
- Have the hydraulic hose line checked at least once a year by a specialist for proper functioning.
- Replace the hydraulic hose line if it is damaged or worn. Only use original **AMAZONE** hydraulic hose lines.
- The hydraulic hose lines should not be used for longer than six years, including any storage time of maximum two years. Even with proper storage and approved use, hoses and hose connections are subject to natural ageing, thus limiting the length of use. However, it may be possible to specify the length of use from experience values, in particular when taking the risk potential into account. In the case of hoses and hose connections made from thermoplastics, other guide values may be decisive.
- Never attempt to plug leaks in hydraulic lines using your hand or fingers.

Escaping high pressure fluid (hydraulic fluid) may pass through the skin and ingress into the body, causing serious injuries!

If you are injured by hydraulic fluid, contact a doctor immediately. Danger of infection.
- When searching for leakage points, use suitable aids, to avoid the serious risk of infection.



2.16.3 Electrical system

- When working on the electrical system, always disconnect the battery (negative terminal).
- Only use the prescribed fuses. If fuses are used with too high a rating, the electrical system will be destroyed – danger of fire.
- Ensure that the battery is connected correctly - firstly connect the positive terminal and then connect the negative terminal. When disconnecting the battery, disconnect the negative terminal first, followed by the positive terminal.
- Always place the appropriate cover over the positive battery terminal. Contact with earth may cause an explosion
- Risk of explosion: avoid the production of sparks or the presence of naked flames in the vicinity of the battery.

3 General description of the machine

3.1 Areas of application

The AMAZONE Groundkeeper is intended to be used for grass cutting and scarifying, for example, in public parks as well as sports fields and gardens.
It can be used to collect and chop foliage in the autumn.

3.2 Declaration of conformity

The machine complies with the requirements of the EC Machinery Directives 2006/42/EC and associated additional guidelines.

3.3 Details required for enquiries

When ordering special optional equipment and spare parts, please remember to quote the **machine number**.



Safety requirements are only fulfilled if original **AMAZONE spare parts are used when a repair is undertaken. The use of other parts may remove liability for any consequences which may occur as a result.**



3.4 Identification of the machine

The rating plate is fitted on the front left-hand side of the machine (Fig. 3.4/1).

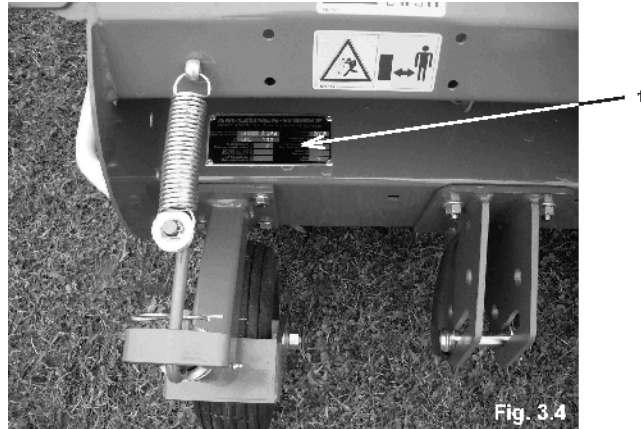

The whole identification plate has the status of a certificate and must not be altered or made unrecognisable.

3.5 Technical data

Model	Working-width	Tractor-attachment	Catcher	Weight	Dimensions L x W x H (m)
GHL-1500	1.50 m	40 kW/53 PS – Cat. I,II	1,800 l	670 kg	1.97 x 1.90 x 1.62
<i>Unloading height approx. 1.90 m</i>					
Front tyres		260 x 85			
Front tyre pressure		1.5 bar			
<hr/>					
GHL-T1350	1.35 m	20 kW/27 PS – Cat. I N,I	1,400 l	730 kg	1.94 x 1.75 x 1.58
GHL-T1500	1.50 m	25 kW/34 PS – Cat. I,II	1,550 l	760 kg	1.94 x 1.90 x 1.58
<i>Unloading height approx. 1.80 m</i>					
Front tyres		260 x 85			
Front tyre pressure		1.5 bar			
Rear tyres		16 x 6.5-8		16 x 6.5-8	
		GHL-T1350		GHL-T1500	
Rear tyre pressure		2 bar			



Tractor attachment:

quoted output values are max. transferred universal joint shaft outputs.

3.5.1 Noise production data

The emission value (noise level) applicable to the working area is:
LpA = 98 dB(A). Measurements were taken under working conditions close to the driver's ear.
Maximum noise emission : LwA = 115 dB(A).

3.6 Intended use

The Amazone Groundkeeper has been designed for conventional use in maintaining grassed open areas and parks (intended use).

Any use which goes beyond these limits is not regarded as the intended use. The manufacturer is not liable for any damages which may result from such use.

The risk involved in such use is borne solely by the user.

Intended use also includes compliance with instructions specified by the manufacturer concerning operation, servicing and maintenance as well as the exclusive use of **genuine AMAZONE spare parts**. The Amazone Lift Groundkeeper may only be used, serviced and maintained by persons who are familiar with the machine and who have received instruction concerning the risks involved.

All relevant accident prevention regulations and any other generally recognised rules concerning safety, occupational health and traffic laws must be observed and the safety instructions listed on the labels attached to the machine must be strictly followed.

Any alteration to the attachment undertaken without consulting the manufacturer will automatically mean the exclusion of all warranty claims against the manufacturer in relation to damages which may be caused as a result of such intervention.



4 Taking delivery of the machine

On receiving the machine, please determine whether transport damage has occurred or whether parts are missing. Compensation will only be possible if claims are reported immediately to the carrier. Please check that all the parts listed on the despatch note have been delivered.

Before commissioning the machine, completely remove all packaging including wires and check lubrication.

5 Attaching and detaching the machine to/from the tractor

5.1 Machine type GHL



Before the machine is attached to the tractor, care should be taken to check that the three point linkage on the machine corresponds to the tractor's attachment category (CAT I or II).

- Release the fastener on the lower link sockets (Fig. 5-1),
- Move the lower link sockets to the required position and fasten in place with 4 screws each.



- Adjust the lower 3-point linkage to the tractor, so that the tractor tire is in contact with the machine front castor wheels.





The diameter of the lower link pins corresponds to CAT I.

Adapter sleeves will have to be used for CAT II.

In order to guarantee that the machine is attached to and detached from the tractor safely, it is recommended that the procedure be carried out in the following sequence:

- Attach the PTO shaft to the free shaft end on the machine. (If freewheel PTO shafts are used, the freewheel must be attached on the machine side).
- Hook the tractor lower link arms into the three point sockets.
- Secure all pins using the appropriate securing plugs.
- Attach the PTO shaft to the tractor's universal joint shaft. (**Caution:** make sure that the PTO shaft is the correct length, otherwise the tractor or the machine's angular gearbox may be damaged when the machine is raised).
- Attach the upper link.

Choice the optimal adjustment of the upper 3-point linkage.

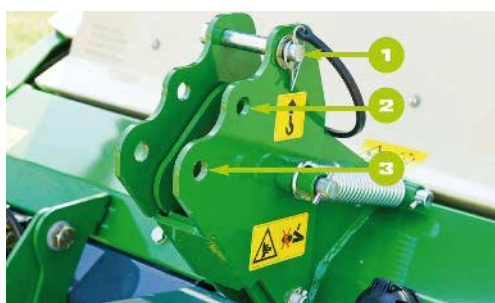

- Pretension the upper link to halfway along the slotted hole (see fig. 5-2/1)



- Plug in the hydraulic lines



- Raise the machine
- Move the safety supports to the working position:
 - Remove the positioning pin
 - Fold the support together (fig. 5-3)



Fig. 5-3

- Secure the support with a positioning pin (fig. 5-4),



Fig. 5-4

- To uncouple the machine, proceed in the reverse sequence.
- If you have a towed GHL-T Lift Groundkeeper, pay attention to the additional information in the section GHL-T.



Instruct those present to leave the danger area behind or underneath the machine, since the machine may lurch backwards if the halves of the upper link have been screwed apart by mistake or if they break apart.



The time it takes for the unit to lower after filling must be at least two seconds. If fitted, adjust the lowering restrictor on the tractor.

5.2 PTO shaft



Only use the PTO shaft specified by the manufacturer:

- Walterscheid W 2300 with or without freewheel for tractors up to max. 40 hp
- Walterscheid W 2400 with or without freewheel for tractors from 40 hp



If you have a tractor without a double clutch for the universal joint shaft drive, you must necessarily use a freewheel PTO shaft.

Otherwise, the tractor will remain in motion due to the flywheel mass of the rotor, even if the clutch pedal has been depressed.

5.3 Fitting and adjusting the PTO shaft

5.3.1 Fitting the PTO shaft



Before fitting, clean the gearbox input shaft on the machine and always use grease to push the PTO shaft onto the input shaft.

5.3.2 Adjusting the PTO shaft when first attached



When first attached, adjust the PTO shaft to the tractor according to fig. 5.2.2. Since this adjustment is only applicable for this one type of tractor, the PTO shaft adjustment must be checked and repeated if the type of tractor is changed.



When attaching other PTO shaft halves onto the tractor's universal joint shaft profile, fit them without sliding the PTO shaft tubes into each other.

1. Hold the two PTO shaft tubes side by side and check whether the PTO shaft tubes provide a guaranteed sliding profile overlap of **at least 40 % of the LO** both when the machine is lowered and raised.
2. When pushed together, the PTO shaft tubes must not knock against the forks of the universal joint. A safety clearance of at least 10 mm must be maintained.
3. To adjust the length, hold the PTO shaft halves alongside each other in the shortest operational position and draw a mark.
4. Shorten the inner and outer protective tube equally.
5. Round off the cut edges and carefully remove swarf.
6. Grease the sliding profiles and slide inside each other.
7. Hook in the supporting chain in such a way that the PTO shaft guard does not turn at the same time during operation.
8. Only use the machine if the drive is fully guarded.

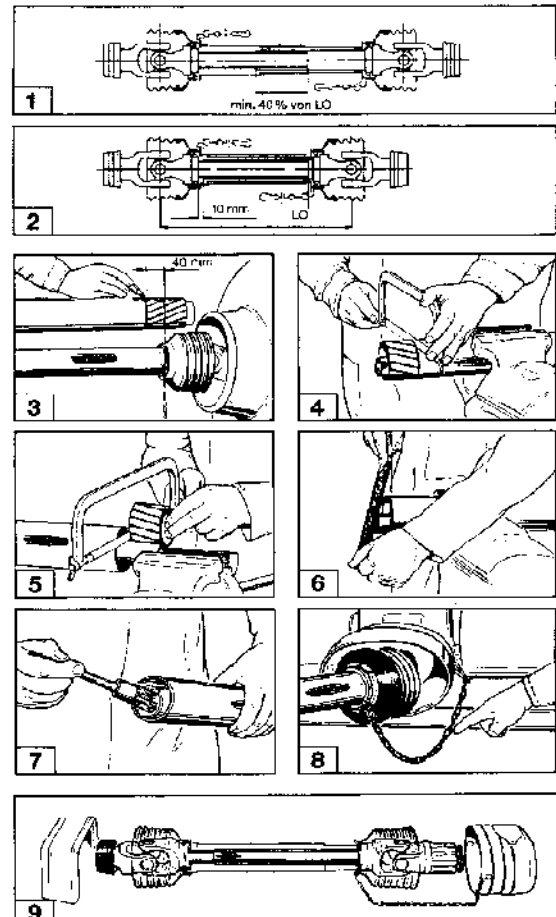

Fig. 5.4.2

Use the PTO shaft with the complete PTO shaft guard and additional guard fitted to tractor and machine. Replace items of protective equipment immediately if they have been damaged.



The angle defining the maximum joint bends in a universal joint on the PTO shaft can be found in the accompanying operating manual provided by the manufacturer.



This manual also contains instructions which must be observed regarding fitting and maintenance operations.

To avoid damage, only connect the universal joint shaft slowly when the tractor engine is running at low revs.



5.4 Groundkeeper transmission input speed

The transmission on the Lift Groundkeepers is equipped with a universal joint shaft connection. The machine must be powered with a maximum drive speed of 540 rpm:

Drive speed $n = 540$ rpm.



Drive speeds higher than specified will cause the rotor to turn at a significantly higher speed. In extreme cases, this may lead to blades being released which could create a hazard for operating personnel.

Warranty claims for damage which can be traced back to an excessively high drive speed of the universal joint shaft will not be recognised.



5.5 Connecting the hydraulics



The maximum permissible hydraulic operating pressure is 200 bar.



The hydraulic system operates under high pressure.



When connecting the hydraulic hoses to the tractor's hydraulic system, care must be taken to ensure that the hydraulic system is free of pressure, both on the tractor side and on the machine side.



All hydraulic hose lines are colour-coded to allow each hydraulic function of the pressure hoses of a tractor control unit to be correctly assigned.

Hydraulic connections:

Plug hydraulic hose lines into the appropriate connections.

Function GH/GHS			
colour	marker		
	1	2	T
red	flow for Hydraulic block		return for Hydraulic block
yellow	Tilt hopper	Lower hopper	
green	Lift machine in back	Lower machine in back	
nature	Drawbar + (Cutting deck operation)		



The time it takes for the unit to lower after filling must be at least eight seconds. If fitted, adjust the lowering restrictor (see fig. 5.5-2 and fig. 5.5-3).

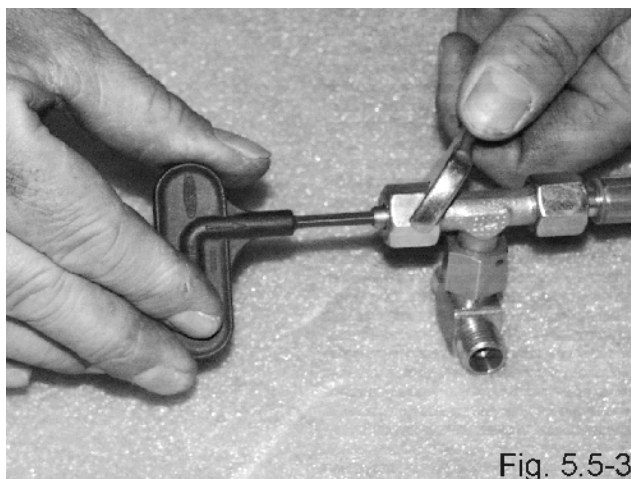
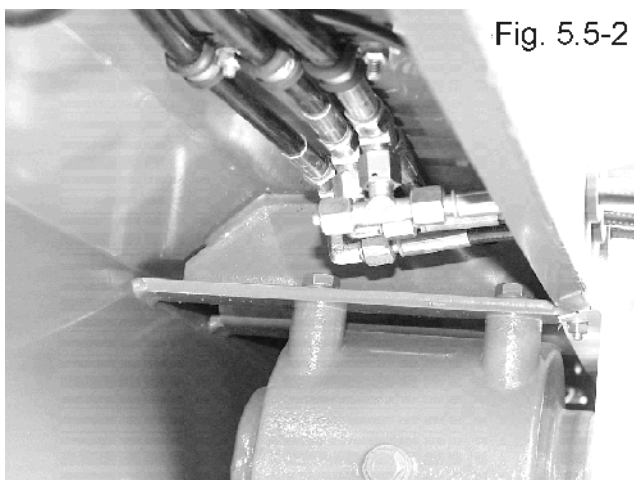



6 The mower unit

The Lift Groundkeeper has a flail-type mower unit. This involves free-moving cutting tools which are suspended on a large-diameter tube. When the rotor starts to turn, the cutting and scarifying blades are erected by centrifugal force, which allows them to reach into the grass which is to be cut and mow it off. The blades are made of special steel and suspended in four rows around the rotor from so-called clip bolts

6.1 Fitting the mowing and scarifying tools

There are 5 different tool arrangements as shown in table 11.

If the mowing blades (tab. 11, A) or scarifying blades (tab. 11, B) have been worn out on one side only, they can be turned round and used again. This is possible because both the front side and the rear side of the edge have been provided with a cutting edge.

The blades can be turned or replaced without the use of tools (fig. 6.1-1).



Care must be taken to ensure that the rotor is equally fitted with blades. If cutting tools are missing or have been incorrectly fitted, an imbalance is created which, over time, will lead to the whole machine being damaged.

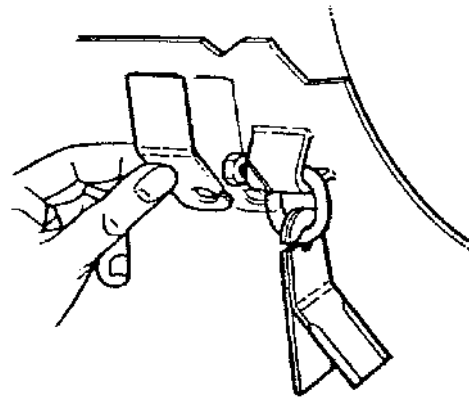

Fig. 6.1-1

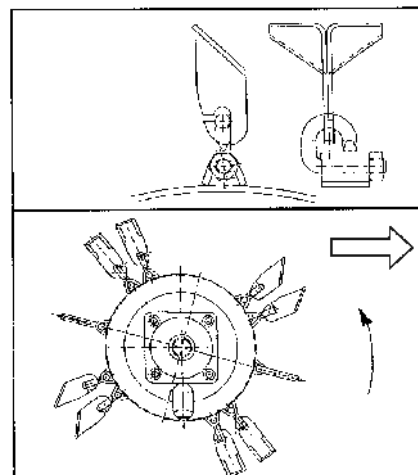

Fig. 6.1-2

	50 %	100 %	100 %	50 %	100 %	100 %
	Mowing blade	Scarifying blade (2 mm)	Scarifying blade (3 mm)	Wing blade, long, H77 ground	Wing blade, long, H77 ground sharpened	Wing blade, H60 ground
	Piece	Piece	Piece	Pair	Pair	Pair
Working width 1.35 m	76 pcs	76 pcs	76 pcs	38 pairs	76 pairs	76 pairs
Working width 1.50 m	82 pcs	83 pcs	83 pcs	72 pairs	83 pairs	83 pairs

Wear limit of suspended tools:

The blade fasteners and clip bolts must be checked regularly for wear. Heavily worn tools must be promptly replaced.

Fig. 6.1-6 and fig. 6.1-4 show the limits of wear for the blades and blade mounting brackets.

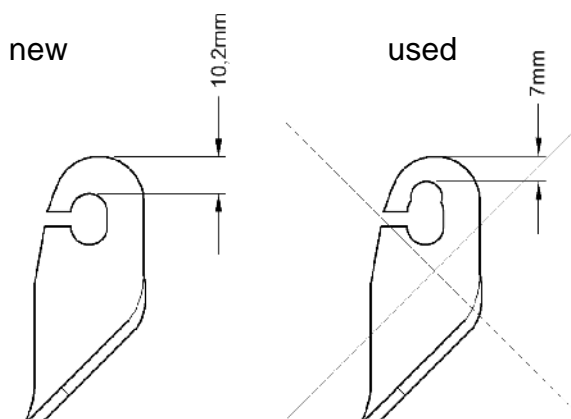

Fig. 6.1-3

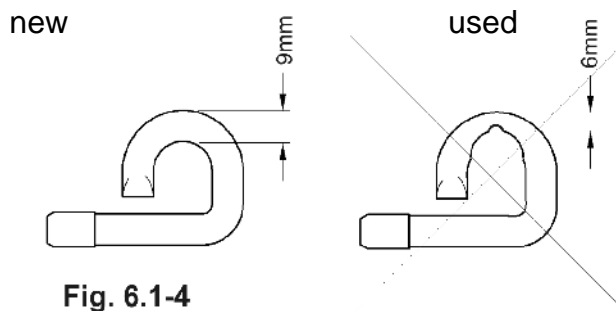

Fig. 6.1-4



CAUTION

The blades and the blade fasteners must be checked before the start of every run.

All screw unions must be firmly tightened.



Blade overview



	A	B	C	D	E
<i>Blade replacement without tools</i>	100 % Mowing blade	100 % Scarifying blade	100 % Mowing and scarifying blade	50 % Mowing 50 % Wing blade, long, H77 (*)	100 % Wing blade, H60 100 % Scarifying blade
Mowing and collecting <i>dry conditions</i>	●●●			●●	
Mowing and collecting <i>wet conditions</i>	●●			●●●	
Scarifying and collecting <i>dry conditions</i>		●●●			
Scarifying and collecting <i>wet conditions</i>		●●			●●●
Collecting Scarified material <i>dry conditions</i>				●●● + 100 % Scarifying blade	●●
Collecting Scarified material <i>wet conditions</i>				●●● + 100 % Wing blade, long, H77 + 100 % Scarifying blade	●●
Mowing, scarifying and collecting in one operation <i>dry conditions</i>			●●●		
Mowing, scarifying and collecting in one operation <i>wet conditions</i>				●●● + 100 % Scarifying blade	
Foliage collection <i>dry conditions</i>	●●●			●●●	
Foliage collection <i>wet conditions</i>	●●		●●	●●● + 100 % Scarifying blade	
Paddock mowing with simultaneous collection of droppings			●●		●●●
Fine mowing and collecting <i>all conditions</i>				●●● 100 % Wing blade, long, H77, ground	

●●● excellent result

●● good result

(*) Pairs of rows opposite one another on the rotor are each fitted with mowing blades or wing blades (fig. 6.1-2).

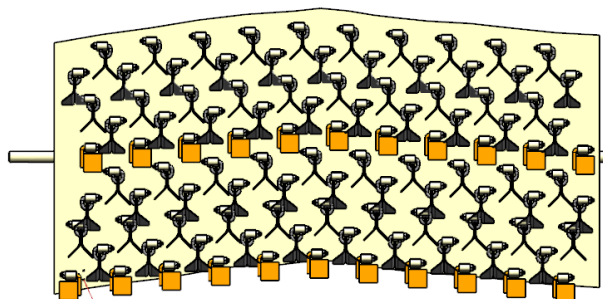

The rotor is accessed in the following manner:

- Attach the machine to a tractor.
- Fully raise the catcher.
- Fit the safety support on the upper right-hand lifting cylinder of the catcher (fig. 6.1-6).
- Turn off the tractor engine.
- Fold up the intermediate hood (fig. 6.1.7).



Caution:

When you intend to work on the rotor with the catcher raised, make sure that the rotor is stationary and fit the safety support on the catcher.





Fig. 6.1-7

6.2 Mowing

The mowing tools described above are used for mowing or scarifying. The working speed depends on the density and wetness of the turf. It must be adjusted to suit the conditions. The maximum PTO shaft speed of 540 rpm must be observed. The catcher must be emptied in good time to ensure tidy collection.

The catcher is fitted with an indicator which shows whether the catcher needs to be emptied (fig. 6.2).

While the indicator is in the lower position, cuttings can continue to be collected. When the pointer starts to approach or has reached the upper position, the catcher must be emptied. The sensitivity of the indicator is dependent on the type of the cuttings.



Fig. 6.2

6.3 Scarifying

Scarifying is usually carried out at the start or end of vegetation growth.

It is possible to clean and aerate turf containing thatch and moss by simultaneously mowing, scarifying and collecting in one operation.

To achieve this, straight scarifying blades are fitted between the pairs of curved mowing blades. If the turf has already been cut short, only the straight blades are fitted. The combination of mowing and scarifying blades produces the best suction effect. Therefore, a combination of mowing and scarifying blades should be used for wet and difficult conditions.

- **Wide scarifying, blade spacing 51 mm**

For this type of scarifying, the rotor is fitted with scarifying blades 2 or 3 mm wide.

Due to the wider spacing between the blades it is possible to work the turf more deeply without causing excessive damage.

Marker for row 1

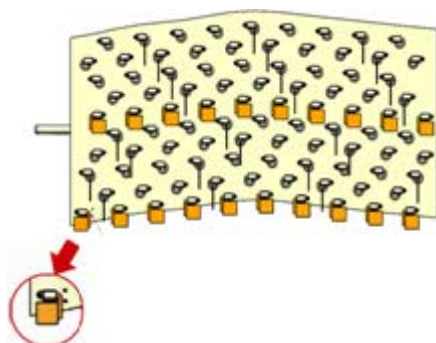

GH 1350

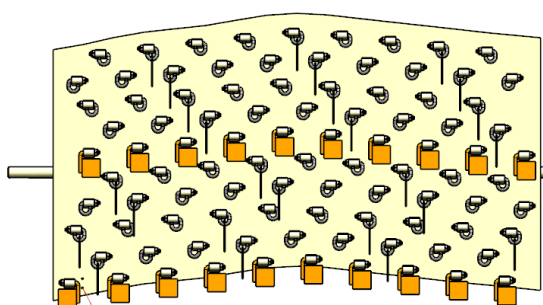

GH 1500

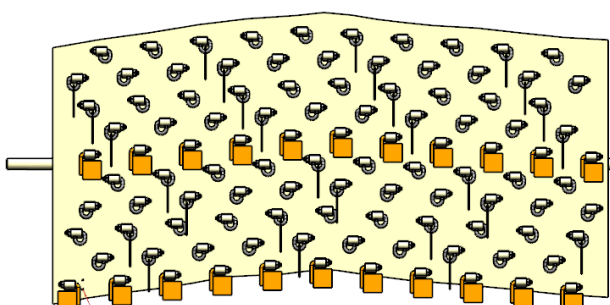



- **Narrow scarifying, blade spacing 17 mm**

All clip bolts on the rotor must be fitted with scarifying blades.

This type of scarifying is relatively aggressive and therefore suitable for restorative work on heavily thatched turf (moss) in the spring.

CAUTION

1. **Care must be taken to ensure that the rotor is fitted with one of the blade arrangements mentioned above. If cutting tools are missing or have been incorrectly fitted, an imbalance is created which, over time, will lead to the whole machine being damaged.**
2. **Only one type of scarifying blade may be used in each case. Risk of imbalance.**
3. **When scarifying produces a high proportion of soil content, only fill the catcher to approximately half way, otherwise there is a risk that the tractor and the machine frame will be overstressed when driving with a full catcher.**
4. **Care must also be taken when driving on uneven terrain with the catcher full and the machine raised, otherwise damage may be caused to the frame.**
5. **When the catcher is full, the machine must only be lowered slowly. If the rear cage roller encounters stones or solid ridges, the machine may suffer damage.**



6.4 Mulching

If the mowing material is only to be cut off, chopped to smaller pieces and deposited back on the ground, the flap which is normally used to guard the rotor when the catcher is raised can also remain closed during mowing.

To set the flap, the operating lever is swung upwards (fig. 6.4-1) and secured in the locking slot provided (fig. 6.4-2). The mulch flap is reset to its normal position when the catcher is raised or lowered.

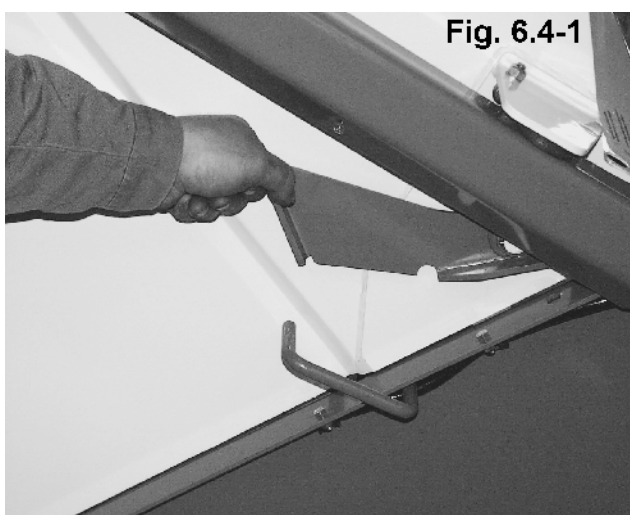

6.5 Collecting

Because of the strong suction effect produced by the rotor, the machine can also be used for collecting material which has already been mowed or any other material lying loose on the ground. The material is then lifted up by air suction, chopped to smaller pieces by the rotating blades and conveyed through the chute to the catcher.



6.6 Emptying the catcher

The machine is first raised by the tractor's three-point hydraulic system. The catcher is then tipped backwards about its swivel axles by the cylinders mounted at the side. When unloading on a slope, the machine must not be positioned across the slope, in order to prevent the tractor and machine from tipping over.



Drive with great care if the catcher is raised.

The closing procedure for the catcher should take at least 8 seconds. It is possible to adjust this lowering speed using the integrated check valve (only on double acting cylinders) (fig. 6.6-1 and 6.6-2).



Fig. 6.6-1

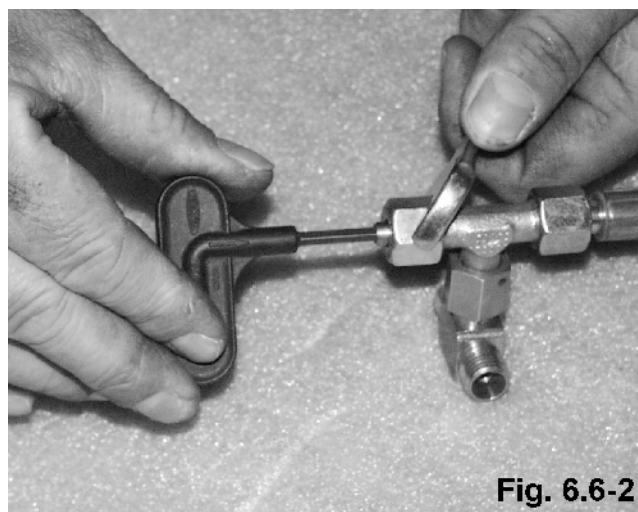

Fig. 6.6-2

7 Adjusting the cutting height

The height of the guide wheels is adjusted by removing and repositioning the distance sleeves (fig. 7-1). To adjust the wheels, it is necessary to raise the machine using the tractor's hydraulic system. The guide wheel retractor must be removed and the sleeves positioned according to the required working height. Then hook the guide wheel retractor back in and secure.



The height of the rear cage roller is adjusted as follows:

- Raise the machine.
- Loosen the clamping screw (fig. 7-2),

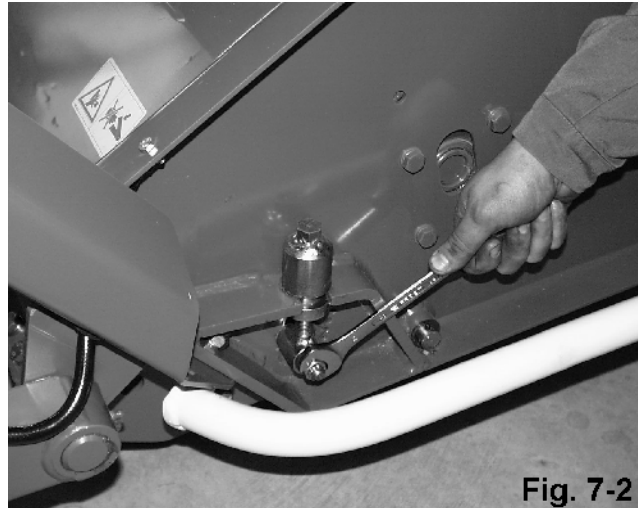

- Move the cage roller into the required position by turning the adjusting screws (fig. 7-3).
- Tighten the clamping screws.

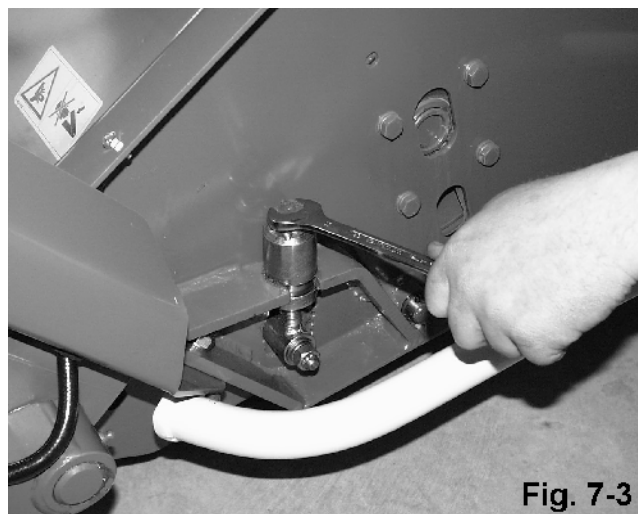

Care must be taken to ensure that the cage roller is equally adjusted on both sides. For this purpose, a check scale has been fitted on both sides (fig. 7-4).

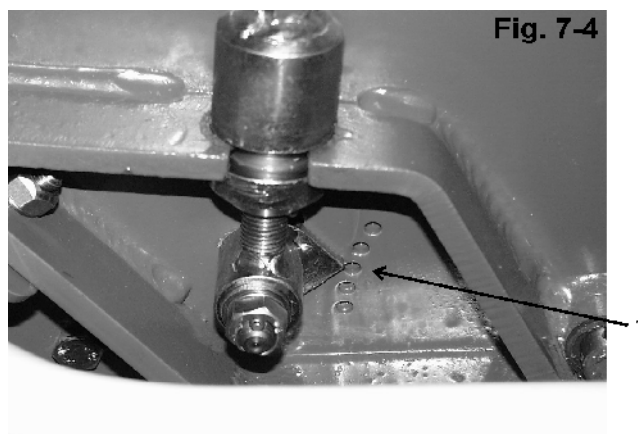

7.1 Front roller

A front roller is available as a special accessory for scarifying on uneven terrain. It is fitted into the holders of the front guide wheels (fig. 7.1-1).



To adjust the height, the lynch pin and the pin must be removed on both sides and the roller must be pegged in the required position (fig. 7.1-2).





8 Cleaning the machine

The machine can, on occasion, become heavily soiled, especially when mowing and scarifying wet grass which is also sometimes interspersed with earth. In such cases, it is recommended to clean the rotor and the catcher intensively with a jet of water.

9 Maintenance are care

The Groundkeeper was designed to be largely maintenance free. The following points, however, must be observed and receive attention. Please also check section 9.4 if you have a towed GHL-T Lift Groundkeeper.

9.1 Oil level in the angular gearbox

The angular gearbox on the machine does not require lubrication servicing. However, the oil level should be checked annually. The inspection screw on the side of the gearbox must be opened (fig. 9.1) in order to check whether the oil level reaches up to the lower edge of the bore hole. The gearbox must be filled with SAE 90 transmission oil (capacity 0.45 l), if required.



9.2 Lubrication points

Depending on the intensity of work, the following areas should be regularly lubricated with multipurpose grease:

- Catcher hinges (fig. 9.2-1).
- Guide wheel fork bearing (fig. 9.2-1).
- Rotor bearings (the V-belt guard on the left-hand side of the machine must be removed for access (WAF 13) (fig. 9.2-2, 9.2-3).
- Rear cage roller bearing (fig. 9.2-4).
- PTO shaft.
- Cage roller bearings (fig. 9.2-5)



Fig. 9.2-1

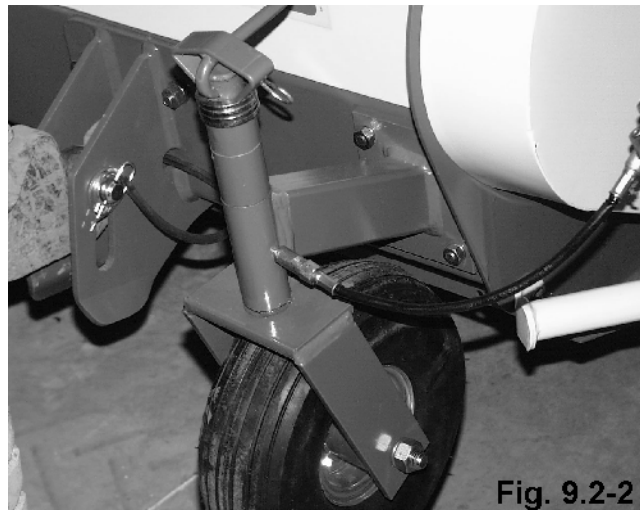
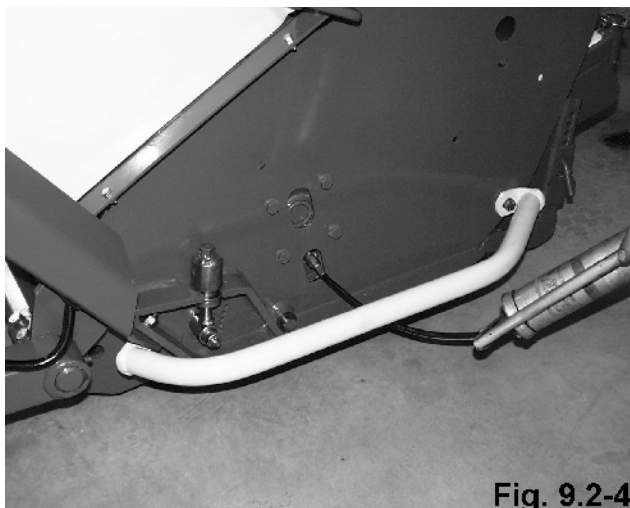

Fig. 9.2-2



Fig. 9.2-3



9.3 Extended periods of downtime

If the machine is not to be used for a long period of time, it is recommended that, before storing, it should be cleaned and protected using a suitable preservative product. Before recommissioning, an authorised garage should check that the overload clutch between the angular gearbox and the belt drive is operating correctly.

9.4 Tyre pressure

Front guide wheels: 2 bar



When removing or fitting tyres, the tyres must always be fully deflated (a split tyre wall can fly apart with explosive force during removal).



10 Additional operating instructions for the towed AMAZONE GHL-T Lift Groundkeeper

The hydraulic, height-adjustable guide wheels at the rear of the machine should primarily be used for attaching the Groundkeeper which can be emptied when raised to tractor types which do not possess sufficient lifting force to raise the standard GHL.

Although this version of the GHL is "towed", the machine can be handled like a three point machine when attached to the tractor. This means that inconvenient manoeuvring in poorly accessible terrain, as is often the case with machines which feature a rigid, single axle design, is no longer necessary.

10.1 Attaching and detaching the machine

Compared with the AMAZONE Lift Groundkeeper, the connection of the hydraulic lines and the upper link are different on this machine.

10.1.1 Hydraulic connections

In order to be able to work correctly with the machine, the following hydraulic connections must be available on the tractor side.

Control valve I (single acting or double acting for accessories double acting hydraulic cylinders catcher)

Connection 1:

Operation of the catcher which can be emptied when raised (fig. 10.1.1/1)

Connection 2:

Operation of the catcher which can be emptied when raised with double acting hydraulic cylinders (accessories) (fig. 10.1.1/2)

Control valve II (single acting with locating position when unpressurised)

Connection 3:

Operation of the rear running gear (fig. 10.1.1/3).

Fig. 10.1.1

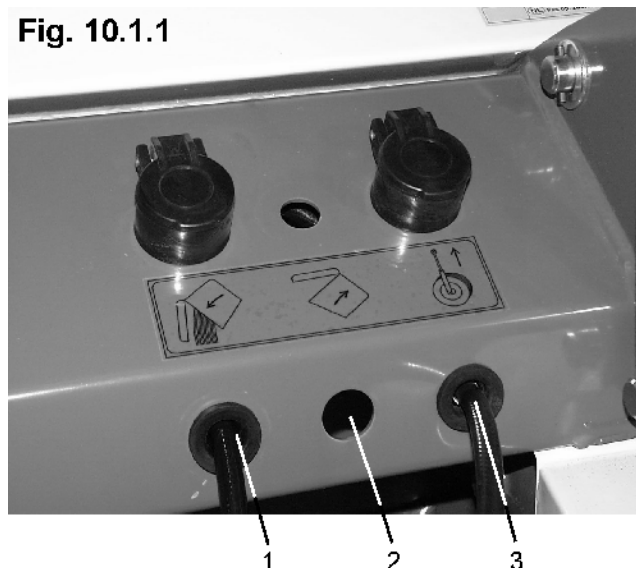



10.1.2 Three-point attachment

The upper link is replaced by a chain. The spring mechanism in the machine's upper three point system allow the front guide wheels to always be in contact with the ground, even on rough, undulating terrain. Differences in the relative movement between tractor and machine are thereby equalised.

The machine is attached in the following sequence:

- Hook in both lower link sockets.
- Secure the lower link pins with lock pins.
- Fit the PTO shaft.
- Connect the hydraulic lines.
- Extend the rear guide wheels to the maximum height. Check PTO shaft length (fig. 10.1.2-1).
- Peg both lugs of the chain with a 19 mm dia. pin to the upper three point mounting rail on the tractor (fig. 10.1.2-2).
- Secure the upper link pin with a safety splint.
- Lower the machine to the working position.



Fig. 10.1.2-1



If the machine is parked on uneven ground after adjustments have been completed, the spring upper link must be pretensioned to approximately half way along the slotted hole (fig. 10.1.2-3). If this is not the case, the active length of the chain on the spring upper link must be corrected. The check should always be carried out if the height adjustment of the front guide wheels or cage roller has been altered.

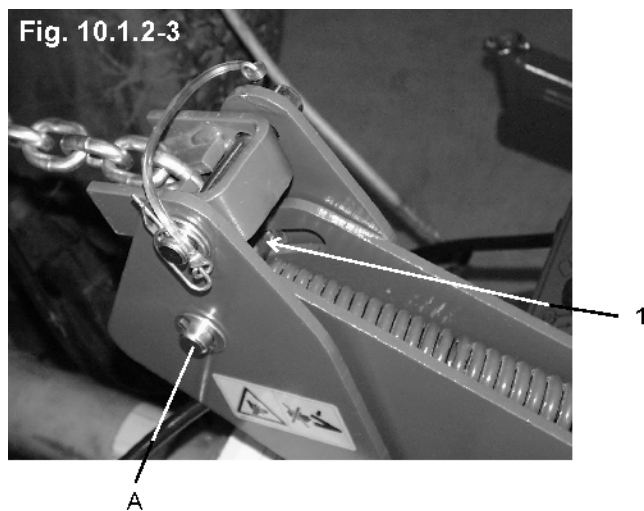

10.1.2.1 Adjusting the spring mechanism

In order to make the best possible use of the machine, the pretension of the upper link can always be exactly adjusted or adapted. By hooking the chain links into the slot of the slotted hole on the upper link, the active length of the chain can be altered as follows:

- Extend the rear guide wheels until the tension on the spring upper link chain has been released.
- Remove the safety splint from the pin of the tension plate (directly behind the slotted plate).
- Remove the pin.



The pin must be easy to pull out of the bore hole. If this is not the case, check whether the spring in the upper link has been detensioned.

- Pull the chain link out of the slotted hole and hook it back in again at the required length (fig. 10.1.2.1).
- Push the pins back in.
- Secure the pins.
- Lower the machine.

If pin A is approximately in the middle of the slotted hole (Fig. 10.1.2-3/1) when the machine has been lowered and is standing upright, work can commence.

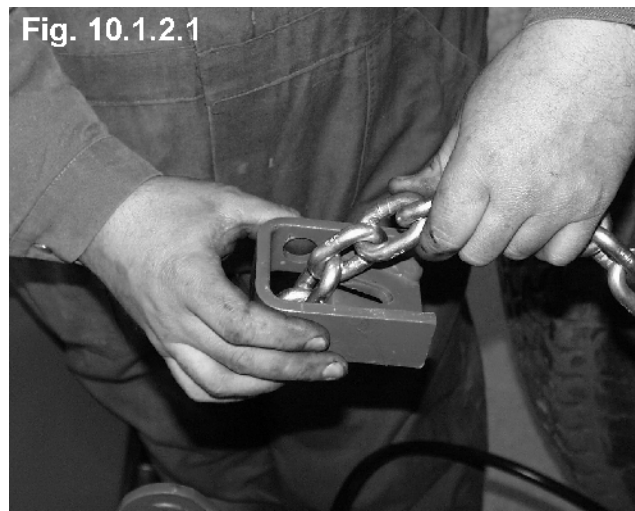

10.2 Transport on public roads

When travelling on the road, the machine must be raised to the required height using the rear guide wheels' hydraulic system and the tractor's lower link arms. The machine must always be positioned as level as possible (fig. 10.2).

The weight of the machine (especially if the catcher is full) should not be underestimated, particularly on tractors with a low kerb weight.





10.2.1 Rear guide wheel vibration damping

On relatively long road journeys, especially if the machine is unladen, it is recommended that vibration damping for the rear guide wheels should be engaged.

This will prevent the guide wheels from swinging backwards and forwards, thereby avoiding increased tyre wear.

Engaging/disengaging vibration damping:

- Reset until the guide wheels are facing away from the direction of travel (fig. 10.2.1-1).
- Remove the lynch pin from the damper sleeve.
- Turn the damper sleeve over (fig. 10.2.1-2).
- Refit the lynch pin.

Damping must be engaged on both guide wheels.



Fig. 10.2.1-1



Fig. 10.2.1-2



When working on soft ground, damping must be disengaged in order that the guide wheels have freedom of movement.

- Damping engaged: no gap visible (fig. 10.2.1-3),
- Damping disengaged: gap visible (fig. 10.2.1-4).

Fig. 10.2.1-3

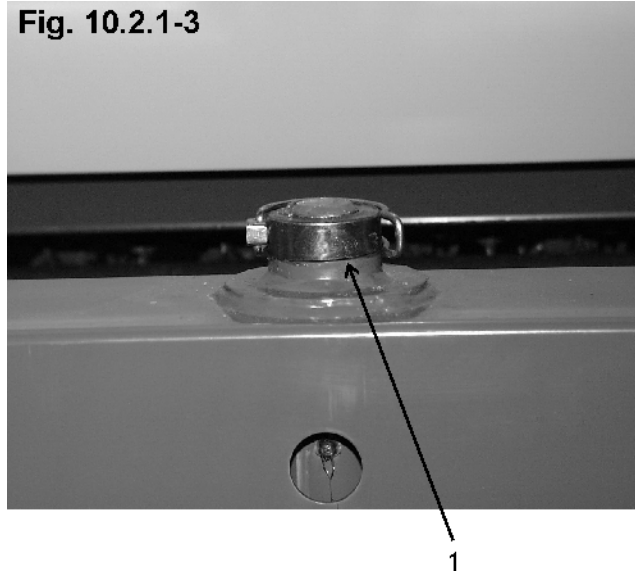
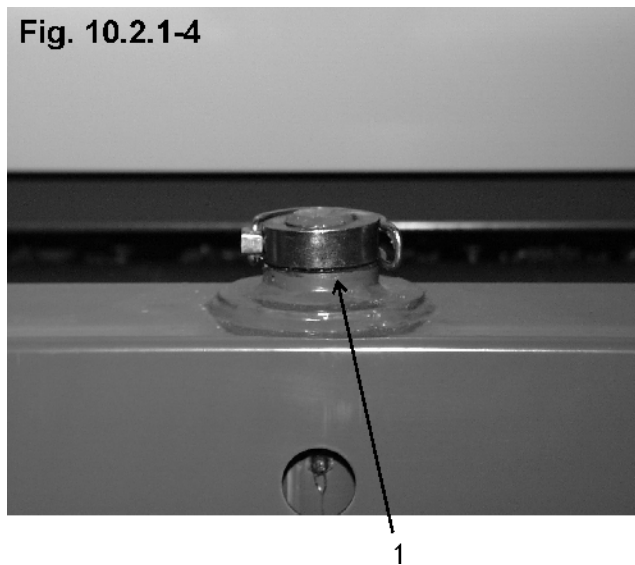

Fig. 10.2.1-4





10.3 Machine in working use

10.3.1 Mowing and scarifying

The mower unit is adjusted and operated in much the same way as the basic GHL machine. There are only differences when it comes to raising or lowering the machine.

The machine should always be raised and lowered evenly, i.e. care should be taken to keep the machine as level as possible in every lifting position. If the machine is raised too much on one side only, whether at the front or rear, damage may be caused to the PTO shaft, if the machine is still running.

When the machine is in the working position, the hydraulic lines for the height-adjustable guide wheels must be unpressurised. Otherwise, on uneven terrain, the cage roller may be raised off the ground unintentionally and, as a result, the cutting height will be uneven.

10.3.2 Emptying the catcher

The rear lifting cylinders have been designed in such a way that they allow the catcher to be emptied at a height of approx. 1.90 m.

Do not start to raise the catcher until you have reached the unloading area.

10.4 After use – uncoupling the machine

After lowering, the machine is tilted forward by extending the rear guide wheels until the spring upper link is detensioned (fig. 10.4). The spring upper link can now be released from the tractor. The machine is then lowered to the ground and uncoupled in the same way as a normal three point machine.



Force must never be used to uncouple the upper link chain, i.e. when it is still under tension, either on the machine side or on the tractor side.



10.5 Maintenance

In addition to the few maintenance tasks which need to be carried out on the AMAZONE GHL Lift Groundkeeper, there are two points which require attention in the case of the GHL-T.

10.5.1 Tyre pressure

Front guide wheels: 2 bar

Rear guide wheels: 2 bar



When removing or fitting tyres, the tyres must always be fully deflated (a split tyre wall can fly apart with explosive force during removal).



10.5.2 Additional lubrication point

- Rear guide wheel damping elements (fig. 10.5.2-1).
- Transport frame pivot point (fig. 10.5.2-2)
- Wheel fork on rear guide wheels (fig. 10.5.2-3)



Fig. 10.5.2-2

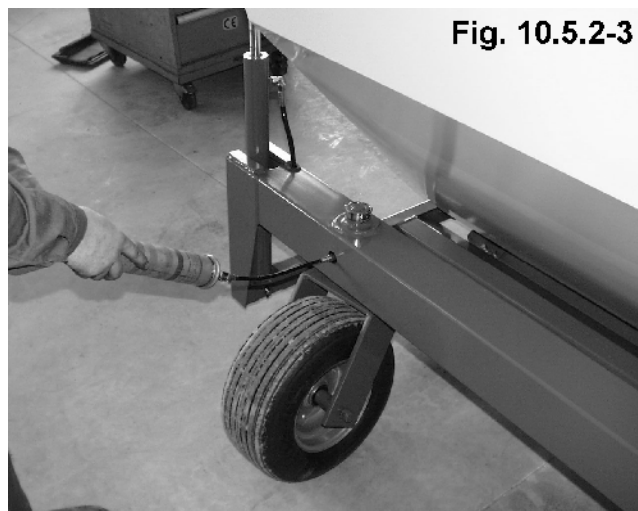



AMAZONEN-WERKE H. DREYER GmbH & Co. KG

Postfach 51
D-49202 Hasbergen-Gaste
Germany

Phone: +49 5405 501-0
e-mail: amazone@amazone.de
[http:// www.amazone.de](http://www.amazone.de)



AMAZONE S.A. FORBACH

17, rue de la Verrerie – BP 90106
F-57602 FORBACH Cedex
France

Tel.: +33 (0)3 87 84 65 70
Telefax: +33 (0)3 87 84 65 71
e-mail: forbach@amazone.fr
[http:// www.amazone.fr](http://www.amazone.fr)

Branch plants: D-27794 Hude • D-04249 Leipzig, Germany • F-
57602 Forbach, France
Subsidiary plants in England and France

Manufacturers of mineral fertiliser spreaders, field sprayers, sowing machines, soil cultivation machines and communal units

