

Operating instructions

AMAZONE

Lift Groundkeeper GHL 120/135/150



AMAZONEN-WERKE H. DREYER
GmbH & Co. KG



D-4507 Hasbergen-Gaste
Tel. Hasbergen (0 54 05) *5 01-0
Telex : 9 4 8 0 1
Telefax : (0 54 05) 50 11 47

AMAZONE-Machines Agricoles S.A.
F-57602 Forbach/France - rue de la Verrerie
Tél : 87.87.63.08 - Télex : 86 04 92 - Téléfax : 87.85.53.23

D-2872 Hude/Oldbg.
Tel. Hude (0 44 08) *801-0
Telex : 2 5 1 0 1 0
Telefax : (0 44 08) 8 0 1 8 7

Fabriken für Mineraldünger-Streuer, -Lagerhallen, -Förderanlagen, Drillmaschinen,
Bodenbearbeitungsgeräte, Universalspritzen, Kartoffelsortier- und -verlesemaschinen,
Kommunalgeräte, Aufbaubehälter für Systemschlepper

OPERATORS MANUAL
INCLUDING THE LIFT GROUDKEEPER GH1 AND GH2
AMAZONE

The AMAZONE "Groundkeeper Lift" is a machine for year round use on parks, sports fields, horse paddocks, golf courses or any other green field site.

In order to get the best possible results from the machine please read and observe these instructions carefully as AMAZONE will not be able to accept any claims under guarantee for damage caused by incorrect operation.

Please enter the machine type and serial number of your AMAZONE Groundkeeper below. These details are quoted on the serial number plate on the front of the main frame just above the right hand lower link point, additionally the serial number is stamped on the front left hand corner of the main frame.

GROUNDKEEPER LIFT GH1 :

TYPE :

SERIAL NUMBER :

Please quote the machine type and serial number when ordering spare parts or making enquiries.

Never put the machine into operation before having read any safety advice supplied with this machine

1.0	<u>Machine Specification</u>	3
1.1	Manufacturer	3
1.2	Technical Data	3
2.0	<u>Advice upon receiving the machine</u>	5
3.0	<u>Putting into operation</u>	5
3.1	Coupling to the three point linkage	5
3.2	Universal joint shaft (PTO)	7
3.3	Setting the PTO input speed	8
4.0	<u>The Rotor</u>	9
4.1	Fitting the mowing or scarifying blades	9
4.2	Setting the cutting plate	13
5.0	<u>Working with the machine</u>	15
5.1	Setting the cutting height	15
5.2	Cutting and scarifying	15
5.3	Mulching	17
5.4	Collecting	18
5.4.1	Optional extras available for collecting	18
5.5	Emptying the hopper	18
6.0	<u>Cleaning the machine</u>	19
7.0	<u>Care and maintenance</u>	19
7.1	Main gearbox oil level	19
7.2	Greasing	19
7.3	Adjusting the operating cord for the mulch flap	21
7.4	Long term storage	21
8.0	<u>Accident prevention advice</u>	23
9.0	<u>Special operating instructions "Groundkeeper GHLT"</u>	24
9.1	Attaching to the tractor	25
9.2	Transport on public roads	27
9.3	Putting into work	30
9.4	Uncoupling the machine	32
9.5	Maintenance	32

GENERAL HEALTH- AND SAFETY PRECAUTIONS

1. Reference to the instruction manual

These "General Health- and Safety Precautions" are an integrated part of the instruction manual handed out to you on receipt of your new AMAZONE-machine. Some of the points in the following refer to very specific AMAZONE-machines and may therefore not apply to the machine you have obtained.

2. Declined use of the machine

The AMAZONE-machine obtained by you has exclusively been designed for the usual operations in agriculture (at municipal machinery for the usual operations in municipal areas).

Any use beyond the one stipulated above is no longer considered as duly use. The manufacturer does not accept any responsibility for damages resulting from this; herefore the operator himself carries the full risk.

Under "duly use" also the adhering to the manufacturers prescribed operation maintenance and repair conditions is to be understood.

AMAZONE-machines may only be operated, maintained and repaired by such persons who have been made acquainted with it and who have been advised about the dangers.

The ministerial accident preventive advices as well as further generally accepted safety technical, working medical and traffic rules should be adhered to.

Any damages resulting from arbitrary changes on the machine rule out a responsibility of the manufacturer.

3. General safety and accident preventive advices

- 3.01 Basic principle: Check traffic and operational safety always before any putting into operation of the machine!
- 3.02 Adhere to the general rules of health- and safety precautions besides of the hints in this instruction manual.
- 3.03 When making use of public roads adhere to the applicable traffic rules.
- 3.04 Become acquainted with all devices and controlling elements as well as with their function **before** beginning with the operation. During this during operation would be too late!
- 3.05 Before beginning to drive check surrounding (children). Ensure sufficient visibility!
- 3.06 The clothing of the operator should fit tight. Avoid carrying any loose clothing!
- 3.07 Sitting or standing on the implement during the operation or during transport is not permissible.
- 3.08 Mount the implement as prescribed. Moving behaviour, steerability and breakability are influenced by mounted implements, trailers and ballast weights. Therefore mind sufficient steerability and breakability!

- 3.09 Adhere to the maximum permissible axle loads and total weights. (Refer to vehicle documents and machine's instruction manual.)
- 3.10 When lifting a three-point-mounted machine the front axle of the tractor is relieved by different amounts depending on the size of the tractor. Always check, that the necessary front axle load of the tractor (20 % of the tractor's net weight) is attained!
- 3.11 When driving into curves mind the projecting to the sides (width) and/or the gyrating mass of the implement!
- 3.12 To avoid sideways swing of the spreading during operation stabilizer bars or chains can be fitted to the tractor's lower arms of the three-point linkage (see tractor accessory).
- 3.13 During driving never leave the operator's place!
- 3.14 Before leaving the tractor lower the machine to the ground. Actuate the fixing brake, stop the engine and remove the ignition key!
- 3.15 Never stay and allow anyone to stay within the operating area! **Warning: Never come near to unguarded rotating shafts, spinner discs, moving booms, arms etc. - danger of injury!**
- 3.16 During the calibration test watch out for danger zones by rotating parts of the machine!
- 3.17 Filling of the machine may only be done with a stopped tractor engine, removed ignition key and closed shutters!
- 3.18 Note maximum permissible filling loads!
- 3.19 Do not place any foreign parts inside the hopper.
- 3.20 Mount the implement only with the prescribed devices.
- 3.21 Special care should be taken when the implement is coupled to or off the tractor.
- 3.22 Secure implement and tractor against unintended rolling away.
- 3.23 Take implement only into operation when all guarding devices are fixed in guarding position.
- 3.24 For fitting the machine to the three-point linkage of the tractor bring all control levers in such a position at which an unintended lifting or lowering is impossible!
- 3.25 When actuating the control levers for the three-point linkage from outside the tractor cabin never step between tractor and implement!
- 3.26 When driving on public roads with a lifted machine the lifting control lever should be locked against unintentional lowering - before leaving the tractor lower the mounted implement onto the ground and pull off ignition key!
- 3.27 Allow nobody to stay between tractor and implement if the tractor is not secured against rolling away by the fixing brake and/or by stopping wedges!

- 3.28 Connect trailed implements according to traffic law. Check function of the trailer brake system. Adhere to manufacturer's advices.
- 3.29 Attach implements and trailers only to the devices provided!
- 3.30 Never exceed maximum permissible load of the coupling drawbar/hitch!
- 3.31 When fitting to the three-point linkage the mounting categories at the tractor and the implement must absolutely coincide!
- 3.32 Working implements should only be transported and driven on tractors which are designed to do this!
- 3.33 Mind maximum permissible axle loads of the tractor (see vehicle documents).
- 3.34 Do not exceed maximum permissible transport measurements of the traffic department.
- 3.35 Fit and check transport gear, e.g. traffic lights, warning- and guarding devices!
- 3.36 Sitting or standing on the implement during the operation or during transport is not permissible.
- 3.37 Make sure that in transport position of the implement the tractor three-point linkage has sufficient lateral immovability.
- 3.38 The release ropes for quick coupler should hang freely and in the low position must not release the quick coupling by themselves.
- 3.39 When fitting hitches care for sufficient movement at the hitch-point.
- 3.40 Affix any ballast weights always as prescribed to the destined fixing points!

Universal joint (P.T.O.) shaft

- 3.41 Use only P.T.O. shafts which are designed for the implement and which are equipped with all legally requested guardings.
- 3.42 Fitting and removing of the P.T.O. shaft only when engine is stopped.
- 3.43 When operating with a switched-on P.T.O. shaft allow no one to stay near to the spinning P.T.O.- or universal joint shaft.
- 3.44 Guard tubes as well as guard cones of the P.T.O. shaft as well as a tractor and implement side P.T.O. guard must be fitted and kept in the correct place.

- 3.45 **ATTENTION:** After switching off the P.T.O. the mounted implement may continue to run by its dynamic masses. During this period never come too close to the implement. Begin to work at the implement only after it has come to a full standstill!
- 3.46 Put to operation P.T.O. shafts only if they are completely equipped with guards also at the implement side!
- 3.47 Connect P.T.O. shaft only after the engine is stopped completely and the P.T.O. shaft has been switched off!
- 3.48 Before switching on the P.T.O. shaft take care, that no one stays in the danger zone of the implement!
- 3.49 Before switching on the P.T.O. shaft ensure that the chosen P.T.O.-speed of the tractor corresponds to the allowable implement input speed.
- 3.50 **ATTENTION:** After switching off the P.T.O. the mounted implement may continue to run by its dynamic masses. During this period never come too close to the implement. Begin to work at the implement only after it has come to a full standstill!
- 3.51 After removal of the universal joint shaft replace protective cap over the tractor's P.T.O.
- 3.52 Clean and grease the universal joint shaft and the P.T.O.-driven implement only after the P.T.O. shaft and engine have been stopped and ignition key pulled off!
- 3.53 Never switch on the tractor P.T.O. while engine is stopped!
- 3.54 Stop P.T.O. always when it is not needed or when the shaft is in an adverse position!
- 3.55 Remedy of damages are to be taken before beginning with the operation!
- 3.56 Ascertain correct fitting and securing of the P.T.O. lock!
- 3.57 Prevent P.T.O. guard from spinning by fixing the provided chain to a nearby static part.
- 3.58 **Matching of the P.T.O. shaft to the tractor**
When first mounting the machine to the tractor, the P.T.O. shaft halves should be separated and the front half should be fixed to the tractor's P.T.O. but not inserted in the implement half which remains on the implement.
Thereafter the two P.T.O. halves should be held side by side. It is now to be ascertained, that in the farthest position of the machine (machine on the ground or hydraulically lifted all the way up) the P.T.O. shaft as well as the P.T.O. -tube overlap in minimum by 6 cm (2 1/2") and that in the nearest position (machine horizontally level) the ends of the yokes do not mate. If they mate both ends must be shortened by the same amount (Fig. 1). (Please check also the various angled position of the broadcaster as stated in the setting chart.)
The two halves of the P.T.O. shaft are now ready for being joint together. Make sure, that under all working conditions the angle of the shaft must not exceed 25 degrees (lubricate P.T.O. shaft and tube). The P.T.O. guard is detachable.

Hydraulic system

- 3.59 On all hydraulically actuated pivoting parts exists danger of injury by bruising and shearing places!
- 3.60 Liquids leaking under high pressure (Diesel fuel, hydraulic oil) can penetrate the skin and cause severe injury. When enjured see a medical doctor immediately. Danger of infection!
- 3.61 The hydraulic system stands under high pressure.
- 3.62 When searching for leaks appropriate aids should be used because the danger of injury.
- 3.63 Before starting to do some repair work at the hydraulic system relieve it from pressure by actuating the control lever accordingly, lower machine to the ground and stop tractor engine.
- 3.64 When fitting the hydraulic hoses to the tractor hydraulic sockets always ensure that the hydraulic system at the tractor as well as at the implement side is without pressure.
- 3.65 Connect hydraulic hoses to the hydraulic rams according to the advices in the instructions.
- 3.66 To avoid wrong hydraulic connection sockets and plugs should be colour coded. This helps to prevent misoperation and reduces the danger of accidents caused by it.
- 3.67 The period of use of any hose circuits should not exceed six years including a possible storing period of two years in maximum. Also when stored and used properly hoses and hose circuits do age. Therefore their longevity and period of use is limited. Deviations from the above may be accepted by the Health- and Safety Authorities and depending on the experience made and the danger potential. For hoses and hose circuits made of thermoplasts other guide lines may prevail.
- 3.68 Before every travel check function of brakes!
- 3.69 The braking systems must regularly be checked!
- 3.70 Setting- and repair work at the brakes must only be conducted by specialised professional workshops or brake service stations. Always use prescribed brake fluids and renew as prescribed.
- 3.71 Dispose of old oils, grease and filters as prescribed by law.
- 3.72 Mounting tyres requires sufficient knowledge and availability of prescribed tools.
- 3.73 Check and retighten if necessary nuts and screws regularly.
- 3.74 Before working at the electric gear disconnect battery cable.
- 3.75 When conducting maintenance work at the lifted implement always place suitable supports underneath.
- 3.76 For replacing any tools with cutting edges always use suited tools and gloves.

- 3.77 When conducting electrical welding operations on the tractor or on the mounted implement remove cable from the generator and the battery.
- 3.78 When working at the tyres make sure that the implement has been placed on the ground safely and that it is secured by wedges against unintended rolling away.
- 3.79 Repairwork on tyres may only be conducted by trained staff and with suited mounting tools.
- 3.80 At excessive air pressure in the tyre, danger of exploding.
- 3.81 Check air pressure regularly.
- 3.82 All bolts and nuts must be tightened to manufacturers specification.

Particulars

- 3.83 Adhere to the recommendations of the manufacturers of the plant protection agents. - Protective clothing! - Warning hints! - Metering-, operation- and cleaning advices!
- 3.84 Notes about the compatibility of spray agents and materials of the implement must be observed.
- 3.85 Materials which tend to gum up or to congeal must never be sprayed.
- 3.86 Stop P.T.O. immediately after the shutters of the fertilizer broadcaster have been closed.
- 3.87 If a filled machine is to be parked without tractor the fertilizer inside the hopper should be levelled - otherwise danger of tipping over!
- 3.88 The trailer hitch provided must only be used for towing suitable implements or twin axle trailers up to a maximum of 25 km/h (outside West-Germany different laws may prevail). Single axle trailers must not be towed under any circumstances.
- 3.89 **Attention:** Never get and never allow any one to get near to rotating spreading discs, danger of injury!
- 3.90 Be careful when staying or when seeing other persons staying within the throwing zone of the fertilizer broadcaster.
- 3.91 Never free stuck fertilizer or seed inside hopper by hand and always stop machine before!
- 3.92 Hydraulic slope correction and hydraulic foldings may only be actuated if nobody stays in the area of movement of machine components.
- 3.93 When turning with unfolded sideparts (booms) watch for persons and traffic!
- 3.94 Mind for proper condition of the supporting cables and supporting connections.

1.0 Machine Specification

1.1 Manufacturer

AMAZONE Machines Agricoles S.A.
F-57602 Forbach/France
Telephone : 87 87 63 08
Telex : 860492
Telefax : 87 85 53 23

1.2 Technical Data

Type	GHL	120	135	150
Cutting width		1.2 m	1.35 m	1.5 m
Overall width		1.35 m	1.5 m	1.65 m
Net weight		384 kg	427 kg	470 kg
Tyre size (front)		260	x	85
Tyre pressure (front)		1,5 bar (22 p.s.i.)		
Total height			1.6 m	
Hopper capacity		1.6 m ³	1.8 m ³	2 m ³

Semi-mounted

Type	GHLT	120	135	150
Net weight		474 kg	497 kg	540 kg
Hopper capacity		1 m ³	1.1 m ³	1.2 m ³
Tyre size (rear)	15 x 6.00 - 6		16 x 6.5 - 8	
Tyre pressure (rear)		2 bar (29 p.s.i.)		



2.0 Advice upon receiving the machine

On receipt check the machine for damage and missing parts. Claims must be immediately to the carrier if compensation is to be obtained please ensure also that all parts listed in the consignment note have been received.

3.0 Putting into operation

3.1 Coupling to the tractor three point linkage

To enable the machine to be safely coupled on and off the tractor the following sequence should be followed :

- (i) Fit the PTO shaft with the larger guard and profile tube section to the machine (where the shaft is fitted with an over-run clutch then the clutch should be at the machine end).
- (ii) Fit the tractor lower link arms to the machine lower link pins and secure with lynch pins.
- (iii) Fit the PTO shaft to the tractor splined shaft. (CAUTION : Check the correct length on the PTO shaft. Do not lift the machine until the PTO shaft has been made to the correct length otherwise damage may occur to the main gearbox). - See point 3.2.
- (iv) Attach the tractor top link and shorten until the machine sits with the full weight on the front caster wheels.
- (v) Correct the hydraulic hose for the hopper tip system to the tractors auxiliary hydraulic system.
- (vi) Lift the machine on the tractor's hydraulic.
- (vii) Fold in the parking legs (fig. 2)

To uncouple the machine the above sequence should be followed in the reverse order.

When coupling the Groundkeeper Lift GH1 'T' please follow additional instructions under part 9.



Fig. 2

3.2 Universal joint (PTO) shaft

Only a PTO shaft of the type W 2200 should be used on this machine. The shaft is attached to the main gearbox input shaft through the guard.

When using the machine with a tractor that does not have a dual clutch the PTO shaft must be fitted with an over-run clutch. This prevents the tractor from being 'driven' forwards by the tremendous momentum of the rotor as it slows.

When attaching the machine to the tractor for the first time do not attach the PTO shaft to the tractor. Instead pull the front half of the shaft out completely and then attach it to the splined shaft of the tractor. Lift the machine into the working position and check the overlap of the PTO shaft by holding both free ends side by side simultaneously lowering the machine to the ground. A minimum overlap of 60mm should be maintained in all lifting positions and conversly the inner and outer tubes must under no circumstances touch the universal joint on the end of each tube. If the PTO shaft halves are too long they must both be shortened by the same amount (including the protective guards). Apply grease to the inner shaft.

Both halves of the PTO shaft guard should be secured with the chains provided to ensure the guard does not turn with the shaft.

Please follow any further instructions supplied by the PTO shaft manufacturers.

3.3 PTO shaft input speed to the main gearbox

The gearbox of the Groundkeeper lift has an input shaft for the PTO shaft drive. The machine should not be used with a PTO input speed that exceeds 540 u/min.

:
:
: MAX. PTO INPUT SPEED = 540 U/MIN
:
:
:
:-----

Higher input speeds result in higher rotor speeds. Under these circumstances some blade loss is possible which may lead to the injury of the operating personnel.

4.0 The rotor

The Groundkeeper Lift is fitted with a flail mower system (fig. 3). The rotor consists of a large diameter tube on to which pairs of cutting knives or scarifying blades are hung. The cutting knives are made from special steel and are fixed in four rows across the full width of the rotor at 1 cm spacing. This guarantees an even clean cutting performance.

4.1 Fitting the mowing and/or scarifying blades

Three blade fitting possibilities exist :

Fig 4 : Mowing knives for grass area cutting

Fig 5 : Scarifying blades for turf aeration work

Fig 6 : Mowing knives and scarifying blades fitted in combination for one pass cutting and aerating.

If the knives become worn then they may be reversed to double their useful life.

CAUTION : Please check regularly the condition of the rotor and its knives, blades and wind baffles. If these are missing or unevenly distributed then excessive vibration will occur. If this is noticed the machine should be stopped immediately and the cause of the vibration remedied.

A vibrating rotor would quickly cause damage to machine which would not be covered by our guarantee.

The knives can be exchanged or reversed without tools (fig. 7). The knife hangers are manufactured with a flattened profile at the extreme end of the hook. This allows the narrow gap in the knife to be forced over the hanger. The knife is replaced in a similar manner.

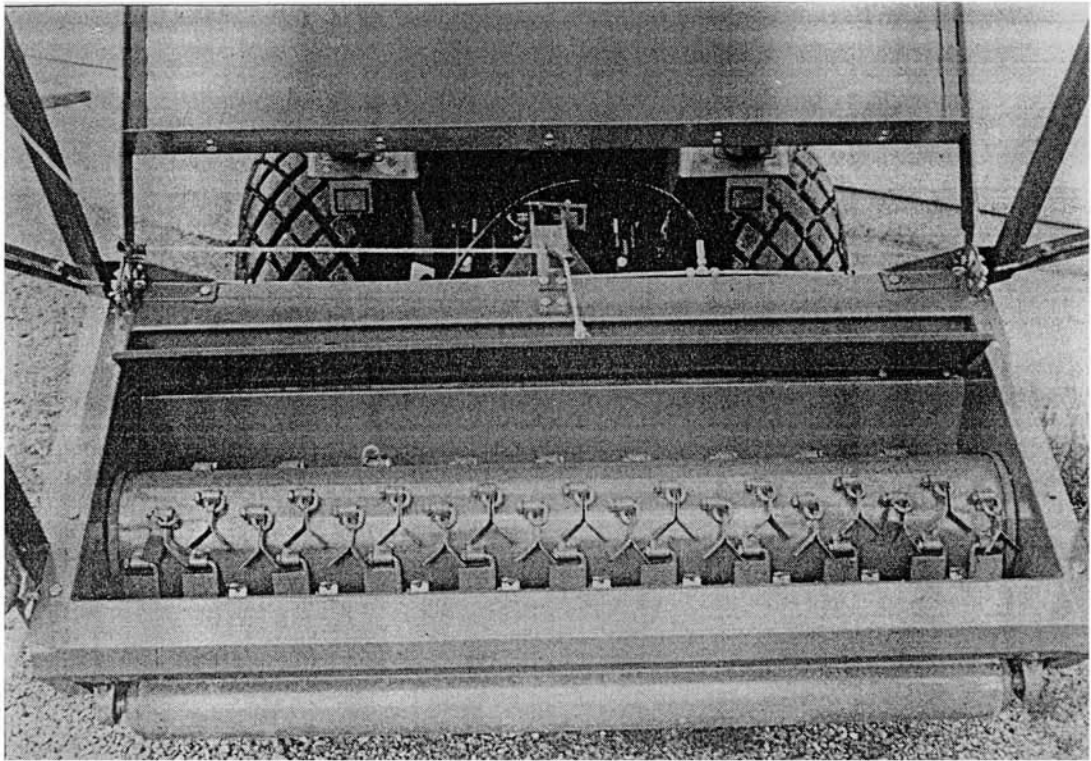
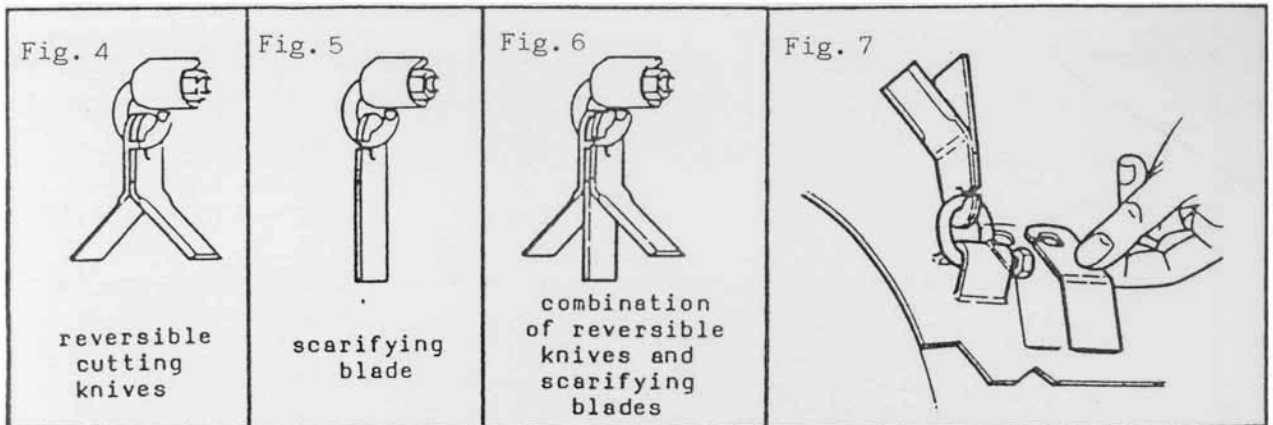

Fig. 3



Access to the rotor is achieved as follows :

- (i) Attach the machine to the tractor
- (ii) Tip the hopper to its extreme position.
- (iii) Drop the ram safety stop over the right hand upper hydraulic ram on the hopper (fig. 8)
- (iv) Switch off the tractor engine.
- (v) Lift the rotor cover (fig. 9)

DANGER : Do not work on the rotor or under the tipped hopper until the rotor has come to a complete stand still and the hopper is supported with the ram safety stop.



Fig. 8



Fig. 9

4.2 Setting the cutting plate

On the back of the rotor cover is mounted a cutting plate. This has the purpose of taking away the mown material from the knives and guide it into the collecting hopper. The cutting plate must be adjusted so that it leaves a minimum of clearance from the knives on blades. For adjusting the cutting plate the supplied setting gauge should be used. If only the mowing knives are fitted the short side of the setting gauge should just fit between the rotor and the cutting plate (fig. 11) whereas if the straight scarifying blade is fitted, or a combination of both, then the long side of gauge is used (fig. 12) the cutting plate is then secured in that position by retightening the bolts.

DANGER : Do not work on the rotor until it has come to a complete stand still.

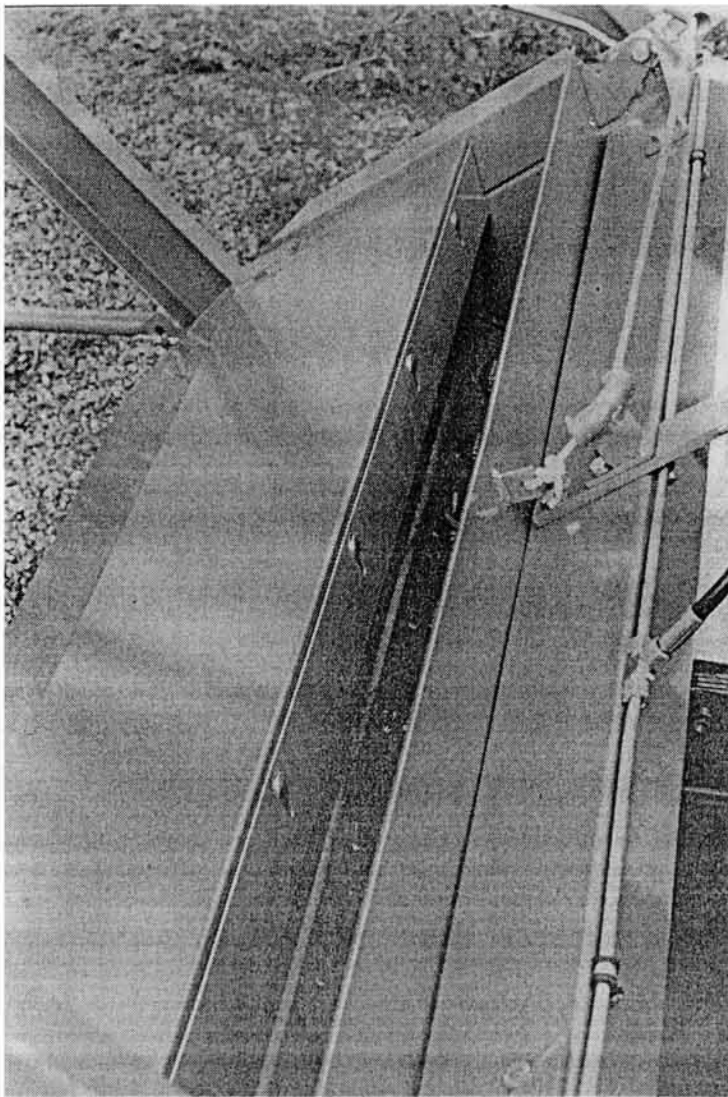

Fig. 10

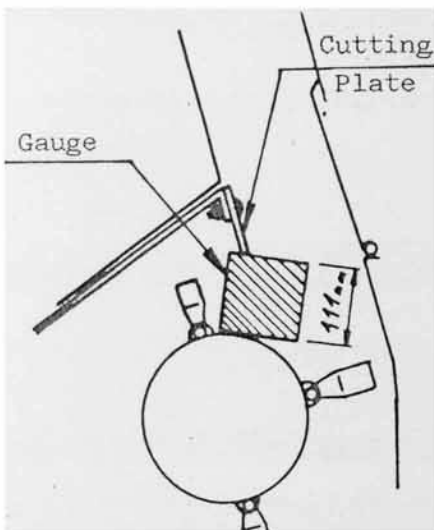

Fig. 11

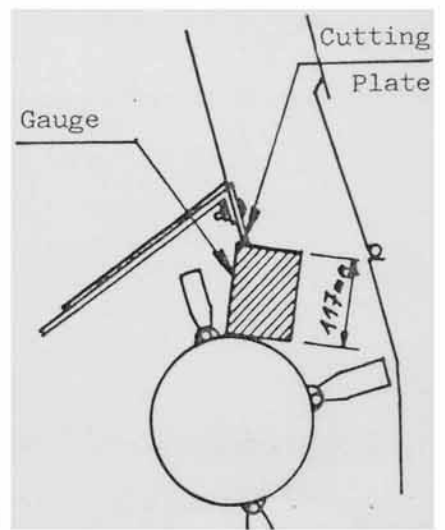

Fig. 12

5.0 Working with the machine

5.1 Setting the cutting height

The cutting height is adjusted by a combination of the rear support roller and the front castor wheels.

The rear support roller is set for mowing the second hole from below (fig. 13a) and for scarifying with new knives in the second hole from above (fig. 13c). When the scarifying knives are used you can put the rear roller in the highest position (fig. 13b). In this position the support roller will be cleaned from sticking soil and grass by the rotating knives and blades which enable operation even under difficult conditions.

The rear roller should be adjusted as follows :

- (i) Lift the machine on the tractor linkage
- (ii) Loosen but do not remove the four M10 fixing bolts (fig. 14) between the main frame and the support roller bearing bracket.
- (iii) Remove the top fixing bolt (fig. 14a).
- (iv) Lift or lower the roller into the desired position and secure with the bolt.
- (v) Tighten all four bolts.

The height of cut can now be set on the front castor wheels. The machine should be lifted on the tractor hydraulics and the desired spacers should be inserted under the castor wheel (fig. 15). The castor wheel is then secured the lynch pin.

5.2 Mowing and scarifying

The operating speed depends on the density and the dampness of the grass to be cut and so this should be set to suit the conditions. A slower forward speed results in a cleaner cut and collection. The maximum input speed of 540 u/min must be adhered to. The collecting hopper should always be emptied early enough to ensure a clean collection as the vertical channel above the rotor becomes congested if the hopper is filled excessively and this will not necessarily clear itself even when the hopper is emptied.

Scarifying is normally carried out at the start or the end of the growing season.

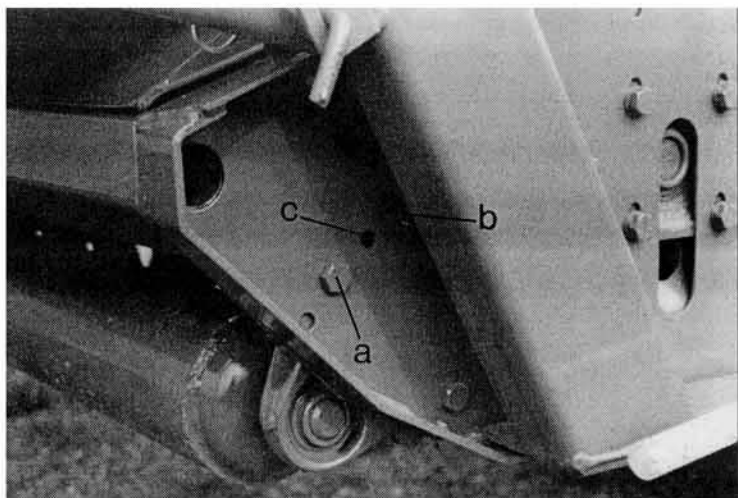

Fig. 13

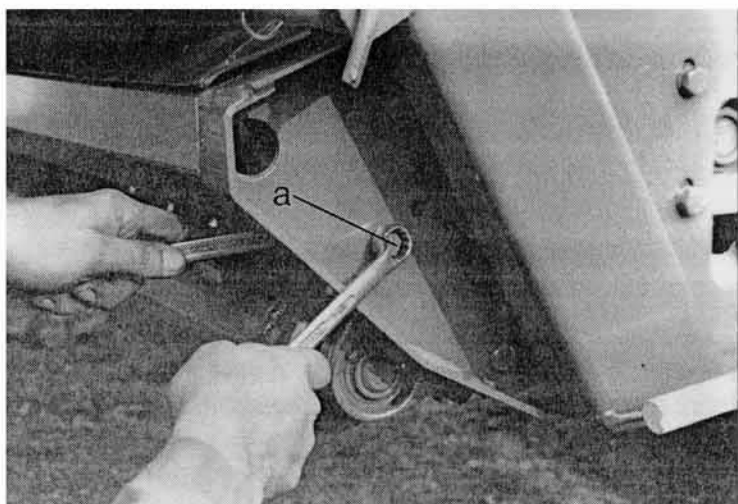

Fig. 14



Fig. 15

To scarify and clean dense mossy lawns it is possible to cut, aerate and collect in one operation. For this the scarifying blade is inserted between the individual mowing knives (fig. 6). When the lawn has already been closely mown it is normal then to scarify using only the straight blade and these may be fitted to all rows or just opposite rows on the rotor. It is imperative however that the rotor remains balanced and hence the blades are used on opposing rows. Set the working height so that the blades are just slitting the soil, however if at this setting damage is being done to the lawn the machine should be lifted.

WARNING :

- (1) When scarifying, with a high proportion of soil material being collected, then it is important not to fill the hopper more than half full. The tractor and the machine would not be able to stand the extra weight that could be collected.
- (2) Damage can occur if the machine is carried fully loaded on the tractor linkage and driven at excessive speed over rough ground.
- (3) With a full hopper, the machine should only be lowered to the ground slowly. Damage can occur to the machine, particularly to rear support roller and bearings, if the machine is dropped quickly especially on rough or stoney ground.

5.3 Mulching

If desired the machine can be set to mow only with no collection. In this instance the flap, which would normally cover the rotor access when the hopper is tipped, should remain closed even when mowing (fig. 16). The flap is opened and shut during normal operation by a nylon cord passing under a hook on the left hand side of the hopper. To mulch, the cord should be unhooked and the flap allowed to close.

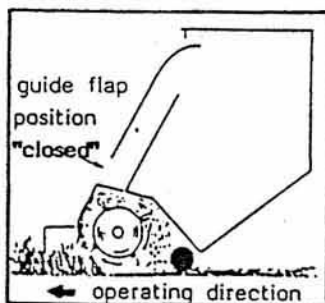
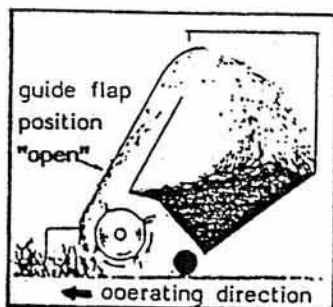

5.4 Collecting

Due to the high suction effect of the rotor, the Groundkeeper can be used for the collection of leaves and litter even on hard surfaces. For this job it is not necessary to convert the machine. The material to be collected is picked up by the vacuum created by the revolving blades, chopped up and blown into the collecting hopper. It may be necessary with light materials to reduce the rotor input speed and hence reduce the amount of material being blown out forwards.

5.4.1 Optional extras for collecting

For the collection of heavy materials, such as extremely wet, short grass cutting, then the vacuum can be increased by the fitting of the optional full width suction plater.

When the machine is being used for cleaning manure from horse paddocks then the special scarifying blade with the lift baffles should be fitted.

5.5 Emptying the hopper

Firstly the machine should be raised fully on the tractor three point linkage. After that the hopper is opened by the appropriate cylinders which not only lift the hopper but also tips to the rear. When unloading on sloping ground care should be taken that when the hopper tips that the tractor and machine do not tip over. In extreme cases this can lead to damage to the machine frame.

CAUTION : do not drive with hopper raised.

6.0 Cleaning the machine

When mowing wet grass it may be possible that it will become mixed with soil which sticks to the lower part of the machine. In this case it is recommended to rinse the hood, the collecting hopper and the rotor with water. Cleanliness ensures optimum operation and increase the longevity of the machine.

7.0 Maintenance

The machine was designed to be nearly maintenance-free. The following points should be noted and adhered to in relation to the maintenance of the Groundkeeper. The additional point under point 9.5 should be noted with reference to the Groundkeeper GHL'T.

7.1 Main gearbox oil level

The oil level in the main gearbox should be regularly checked with the oil level plug on the side of the gearbox. At least annually the level plug should be removed (fig. 17) and the gearbox topped up to the bottom of the level plug with EP 140 gear oil.

7.2 Greasing

During intensive operation the following areas should be lubricated weekly with a general purpose grease.

- (i) Pivot points of the collecting hopper (fig. 18)
- (ii) Front castor wheels (fig. 19)
- (iii) Rotor bearing (the belt cover must be removed from the left handside to gain access) (fig. 20, 21).
- (iv) PTO shaft universal joints and profile tubes.

Regular maintenance ensures optimum operation and machine longevity.

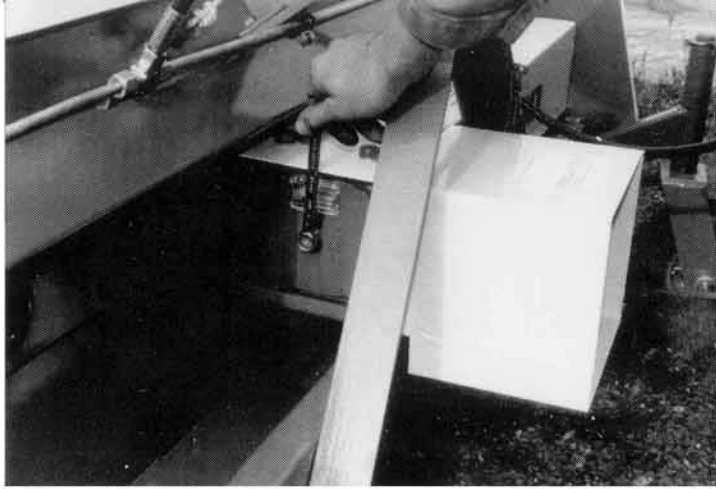

Fig. 17



Fig. 18



Fig. 19



Fig. 20



Fig. 21

7.3 Adjustement of the mulch flap operating cord

After long operating periods it is possible that the nylon cord, which automatically operates the mulch flap when the hopper is raised and lowered, can become stretched. In this case the flap will not open completely affecting the collecting performance of the machine.

To retension the cord open the hopper fully and lift the safety stop loosen the knot at the fastening point to the frame and pull the cord tight until the mulch flap just starts to lift from the rotor head (fig. 22) the cord should then be refastened.

7.4 Long term storage

Before the machine is to be stored for any length of time it should be thoroughly cleaned and then sprayed with oil to preserve it from corrosion. It is then recommended that before use the function of the slip clutch gearbox and belt drive are checked by an authorised AMAZONE dealer.



Fig. 22

8.0 Safety instructions

Please ensure that all personnel that are likely to operate the machine are fully familiar with the operating instructions and relevant safety advice, the following points should be in particular adhered to :

- (i) Work on the machine only when the rotor is at a complete stand still and the tractor engine is switched off.
- (ii) Note that the rotor will continue to run on for some time after the drive has been switched off.
- (iii) Regularly check the condition of the rotor and the cutting knives. Replace any missing or damaged knives, blades or wind baffles.
- (iv) Do not exceed 540 u/min PTO input speed.
- (v) Use only original AMAZONE spare parts particularly blades/knives and hangers.
- (vi) The danger exists of people being hit by stones thrown from the front and side of the machine. Please ask people to stay well clear of the area around before starting work.
- (vii) Do not uncouple the machine from the tractor without first letting down the parking support legs. Otherwise the danger exists of the machine falling over backwards.
- (viii) When operating under a raised hopper always ensure that ram safety stop is in place.
- (ix) Do not uncouple the machine with the hopper raised.

9.0 Special operating instruction Groundkeeper GHL 'T'

The hydraulically operated rear wheels on the Groundkeeper GHL 'T' enable the high lift machine to be operated on tractors with a small lift capacity at the three point linkage than is possible with the standard GHL machine.

The trailed version of the GHL can also be mounted to the three point linkage of the tractor. This way cumbersome manoeuvring in difficult terrain can be avoided as would be the case with machines that are designed in the traditional trailed single axle design.

CONTENTS

9.1 Attaching to the tractor

9.1.1 Hydraulic connection

9.1.2 Fitting to the three point linkage

9.1.2.1 Adjusting the sprung top link

9.2 Transport on public roads

9.3 Putting into work

9.3.1 Mowing and scarifying

9.3.2 Emptying the hopper

9.4 Uncoupling the machine

9.5 Maintenance

9.5.1 Tyre pressure

9.1 Attaching to the tractor

Fitting is the same as the Groundkeeper Lift with the exception of the hydraulic hose system and the top link (see point 3).

9.1.1 Hydraulic connections

For normal operation of the machine the tractor should be equipped with two single acting speed valves (or double with a float position)

Hose 1 : Operating the hopper emptying

Hose 2 : Operating the rear transport wheels

It is imperative that the speed valves used have the facility for pressure-free return of oil from the machine hydraulic cylinders.

9.1.2 Fitting to the tractor three point linkage

The main difference to the standard three point linkage machine is the use of a special spring loaded top link to replace the standard top link. This spring top link ensures that the machine is capable of following the undulations so that the front support wheels are always in contact with the ground especially on uneven work. Couple the machine following the points below :

- (i) Attach both lower link arms
- (ii) Secure with a lynch pin
- (iii) Connect the PTO shaft
- (iv) Connect the hydraulic hose system
- (v) Raise the rear support wheels to the maximum height position (care should be taken not to trap the free end of the sprung top link or that the PTO shaft is not too angled)
- (vi) Connect the two plates of the chain end of the top link to the tractor top link point
- (vii) Secure the top link pin with the "R" clip
- (viii) Lower the machine to the working position

With the machine set into the operating position on level ground the sprung top link should be half stretched, if this is not the case then the top link should be reset. The sprung top link must be adjusted if the front castor wheels or the rear support roller are altered.

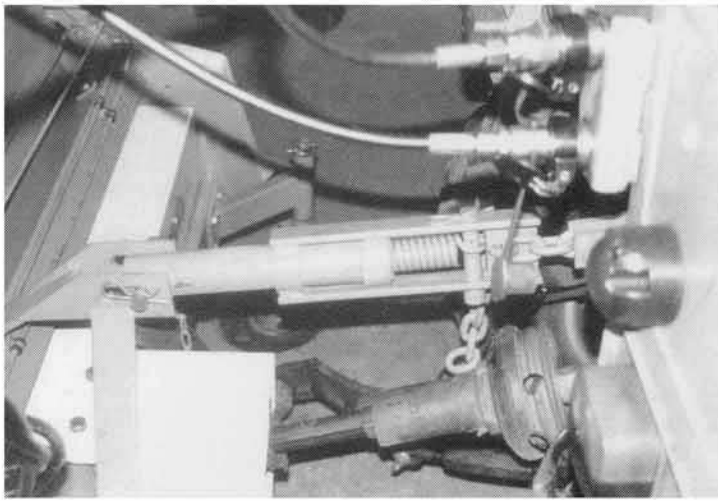

Fig. 23

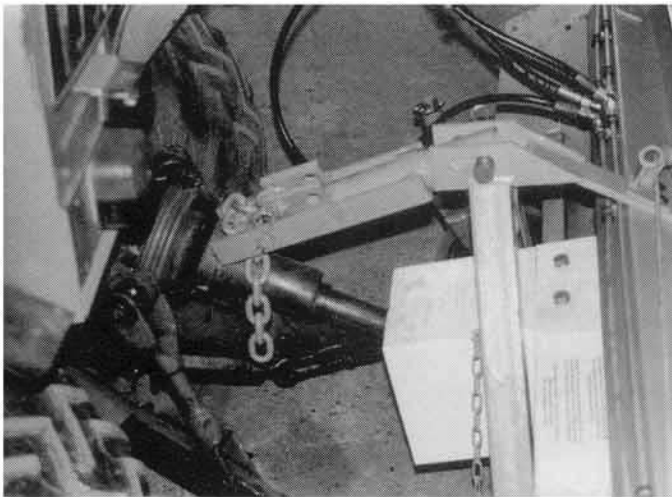

Fig. 24



Fig. 25

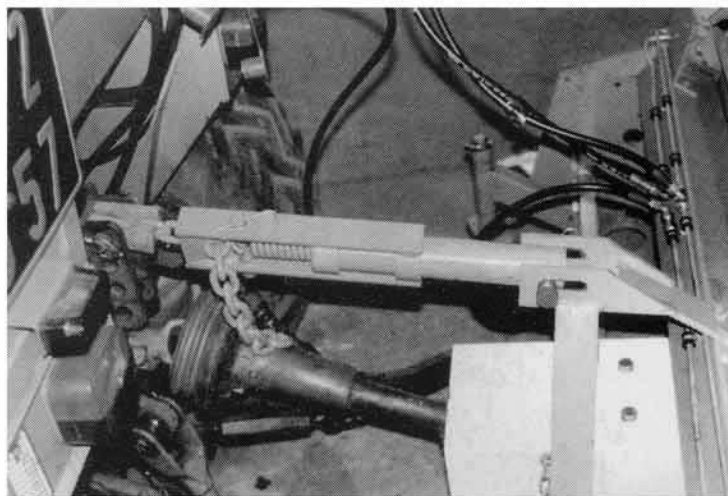

Fig. 26

9.1.2.1 Adjusting the spring top link

With the machine set to the correct operating position then the sprung top link should be under tension. By securing the link of the chain in the slot of the top link the chain can be adjusted to the correct length.

- (i) Raise the rear wheels until the chain goes slack
- (ii) Remove the "R" clip from the pin through the spring
- (iii) Remove the pin from the top link

Caution The pin should be easily removed from the hole if this is not the case then it is possible the spring is under tension still and this should be released before continuing.

- (iv) Secure the chain link into the slot at the correct length
- (v) Replace the pin into the top link ensuring that the pin is passed through the spring
- (vi) Replace the "R" clip into the pin
- (vii) Lower the rear wheels to tension the top link

Now the sprung top link should be approximately half tensioned on the guide tube and in this position the machine can be worked. This position should be noted for future reference.

DANGER When lowering and raising the machine take care not to get trapped in the top link.

9.2 Transport on public roads

During road transport the machine is carried on the rear hydraulic wheels and the tractor lower link arms at the desired height with the machine in a horizontal position, ie., the rear of the machine should be raised to the same as the front.

For all tractors with a small net weight the weight of the machine, especially with a full hopper, should never be underestimated and the effect this has on the driveability of the tractor.



Fig. 27

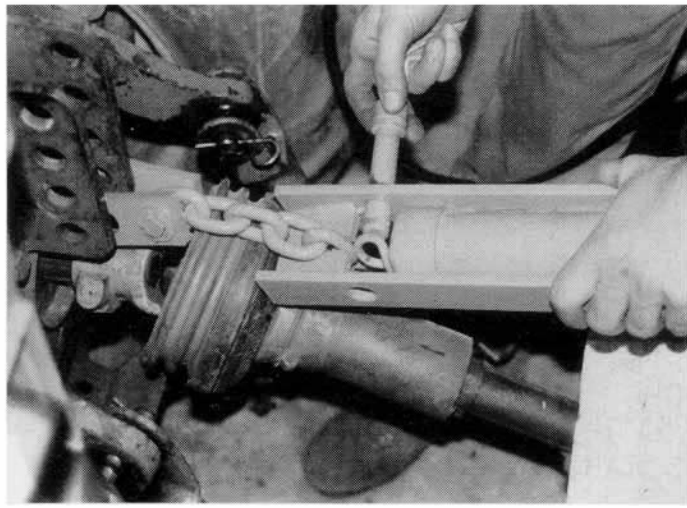

Fig. 28



Fig. 29

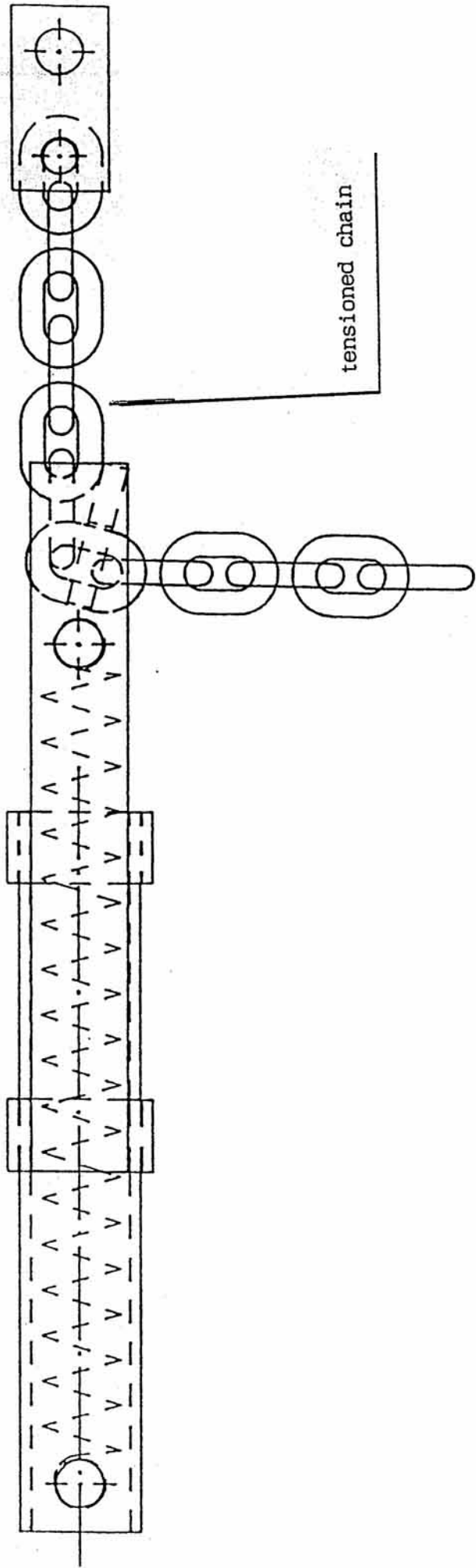

Fig. 30

Setting the sprung top link

Tractor side

Machine side



9.3. Putting into work

9.3.1. Mowing and scarifying

The setting of the machine alterations to the rotor are the same as the basic model, only the lowering and raising of the machine are different.

The machine should always be raised and lowered to the same height, ie., the machine should always be set in work so that the hydraulic system to the rear support wheels is pressure-free. This will ensure that the machine can follow the contours of the ground with the rear support roller in contact with the ground and hence the cutting height is maintained.

9.3.2. Emptying the hopper

The hydraulic rams on the rear wheels are so designed that it is possible to empty the hopper to a height of 1.9m.

Begin to open the hopper only when the machine is up against the trailer or waste removal system.

9.4. After operation - uncoupling the machines

The machine should be raised on the rear wheels until the sprung top link goes loose. The top link is then removed from the tractor. The rear wheels are then lowered and the machine removed from the tractor in the usual manner.

Note : Leave the sprung top tensioned to the correct setting.

9.5. Maintenance

The maintenance program as described in paragraph 7 for the standard Groundkeeper Lift should be followed.

9.5.1. Tyre pressure

Rear wheel tyre pressure - 2 bar



Fig. 31

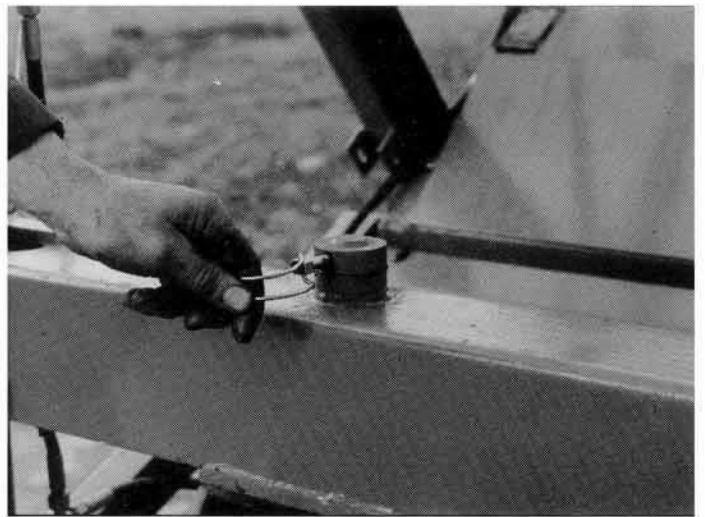

Fig. 32



Fig. 33

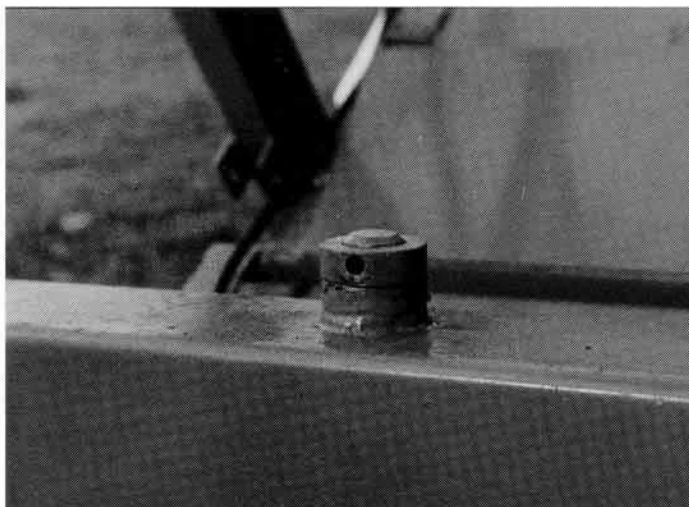

Fig. 34



Fig. 35

AMAZONE Machines Agricoles S.A.

A series of horizontal dotted lines for text entry, consisting of 25 lines spaced evenly down the page.