

Kubota

U.S.A. : **KUBOTA TRACTOR CORPORATION**
3401 Del Amo Blvd., Torrance, CA 90503, U.S.A.
Telephone : (310)370-3370

Western Division : 1175 S. Guild Ave., Lodi, CA 95240
Telephone : (209)334-9910

Central Division : 14855 FAA Blvd., Fort Worth, TX 76155
Telephone : (817)571-0900

Northern Division : 6300 at One Kubota Way, Groveport, OH 43125
Telephone : (614)835-1100

Southeast Division : 1025 Northbrook Parkway, Suwanee, GA 30024
Telephone : (770)995-8855

Canada : **KUBOTA CANADA LTD.**
5900 14th Avenue, Markham, Ontario, L3S 4K4, Canada
Telephone : (905)294-7477

Delta Distribution Center : 7979 82nd St, Delta B.C. V4G 1L7
Telephone : (604)940-6061

Drummondville Distribution Center : 5705 Place Kubota, Drummondville, Québec, J2B 6B4
Telephone : (819)478-7151

France : **KUBOTA EUROPE S.A.S**
19-25, Rue Jules Verdecruysse, Z.I. BP88, 95101 Argenteuil Cedex, France
Telephone : (33)1-3426-3434

Italy : **KUBOTA EUROPE S.A.S Italy Branch**
Via Grandi, 29 20068 Peschiera Borrome (MI) Italy
Telephone : (39)02-51650377

Germany : **KUBOTA (DEUTSCHLAND) GmbH**
Senefelder Str. 3-5 63110 Rodgau /Nieder-Roden, Germany
Telephone : (49)6106-873-0

U.K. : **KUBOTA (U.K.) LTD.**
Dormer Road, Thame, Oxfordshire, OX9 3UN, U.K.
Telephone : (44)1844-214500

Spain : **KUBOTA ESPAÑA S.A.**
Avenida Reomba No.5, Poligno Industrial la Laguna, Leganes, 28914 (Madrid) Spain
Telephone : (34)91-508-6442

Australia : **KUBOTA TRACTOR AUSTRALIA PTY LTD.**
25-29 Permas Way, Truganina, VIC 3029, Australia
Telephone : (61)-3-9394-4400

Malaysia : **SIME KUBOTA SDN. BHD.**
No.3 Jalan Sepadu 25/123 Taman Perindustrian Axis,
Seksyen 25, 40400 Shah Alam, Selangor Darul Ehsan Malaysia
Telephone : (60)3-736-1338

Philippines : **KUBOTA AGRO-INDUSTRIAL MACHINERY PHILIPPINES, INC.**
155 Panay Avenue, South Triangle Homes, 1103 Quezon City, Philippines
Telephone : (63)2-9201071

Taiwan : **SHIN TAIWAN AGRICULTURAL MACHINERY CO., LTD.**
16, Fengping 2nd Rd, Taliiao Shiang Kaohsiung 83107, Taiwan R.O.C.
Telephone : (886)7-702-2333

Indonesia : **P.T. KUBOTA INDONESIA**
JALAN. Setyabudi 279, Semarang, Indonesia
Telephone : (62)-24-7472849

Thailand : **THE SIAM KUBOTA INDUSTRY CO., LTD.**
101/19-24 Navanakorn, Tambol Klongneung, Amphur Klongluang, Pathumtani 12120, Thailand
Telephone : (66)2-529-0363

Korea : **KUBOTA KOREA CO., LTD.**
106-24 Mongsan-Ri, Mankyung-Up, Kimje-City, Chonrapuk-Do, KOREA
Telephone : (82)-63-544-5822

India : **KUBOTA AGRICULTURAL MACHINERY INDIA PVT. LTD.**
Regus, Level 2 Altius, Olympia Tech Park, No.1 SIDCO Industrial Estate, Guindy, Chennai 600032, TN, India
Telephone : (91)-44-4299-4237

Vietnam : **KUBOTA VIETNAM CO., LTD.**
Lot B-3A2-CN, My Phuoc 3 Industrial Park, Ben Cat District, Binh Duong Province, Vietnam
Telephone : (84)-650-3577-507

KUBOTA Corporation

Code No.
N° de code. K7583-7131-2
Code-Nr.

OPERATOR'S MANUAL MANUEL DE L'UTILISATEUR BEDIENUNGSANLEITUNG

KUBOTA *RTV900*

UTILITY VEHICLE
VÉHICULE UTILITAIRE
NUTZFAHRZEUG

[Homologated Version]
[Version Homologuée]
[Beglaubigte Version]



1AYAACKAP0010

RTV900

READ AND SAVE THIS MANUAL
MANUEL A LIRE ET A CONSERVER
DIESE ANLEITUNG SORGFÄLTIG
DURCHLESEN UND AUFBEWAHREN

Kubota

KUBOTA Corporation C'EST ...

Depuis sa fondation en 1890, KUBOTA Corporation a progressé pour figurer au rang des plus grandes entreprises du Japon.

Pour parvenir à cette position, la Société a diversifié, au cours des années, la gamme de ses produits et services de façon remarquable.

Aujourd'hui, 19 usines et 16,000 employés produisent plus de 1,000 articles et produits différents petits et grands.

Tous ces produits et les services qui en dépendent sont toutefois liés à un souci majeur:

KUBOTA fabrique des produits qui, pris à une échelle nationale sont des nécessités de base, produits indispensables, produits conçus pour aider les hommes et leurs nations à tirer parti du potentiel inhérent à leur environnement, KUBOTA est le géant des nécessités de base.

Ce potentiel inclut l'approvisionnement en eau, la production d'aliments tirés du sol et de la mer, le développement industriel, l'architecture et la construction, les transports.

Des milliers de personnes font confiance au savoir faire de KUBOTA, à sa technologie, à son expérience et à son service après vente, vous aussi pouvez faire confiance à KUBOTA.

KUBOTA ist ...

Seit der Firmengründung im Jahre 1890 ist KUBOTA zu einem der wichtigsten Unternehmen in Japan angewachsen.

Hierzu hat zum großen Teil die ständige Erweiterung der Produktpalette und das ständig wachsende Angebot an Dienstleistungen beigetragen. Heute werden von 16000 Beschäftigten in 19 Werken mehr als 1000 verschiedene Produkte hergestellt.

Das vorrangige Ziel von KUBOTA ist es, mit seinen Produkten und den dazugehörigen Dienstleistungen Grundbedürfnissen gerecht zu werden, auch auf internationaler Ebene.

Die von KUBOTA hergestellten Produkte sind unverzichtbar; sie helfen einzelnen Personen, sogar ganzen Nationen die örtlich gegebenen Möglichkeiten in Bereichen wie Wasserversorgung, Landwirtschaft, Fischerei, Industrie, Architektur, Bau- und Transportwesen bestmöglich auszuschöpfen. Tausende bauen auf KUBOTA -und Sie?

OPERATOR'S MANUAL

ENGLISH

KUBOTA *RTV900*

UTILITY VEHICLE



1AYACKAP0010

READ AND SAVE THIS MANUAL















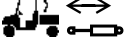









Kubota

ABBREVIATION LIST

Abbreviations	Definitions
2WD	Two Wheel Drive
4WD	Four Wheel Drive
API	American Petroleum Institute
ASABE	American Society of Agricultural and Biological Engineers, USA
ASTM	American Society for Testing and Materials, USA
DIN	Deutsches Institut für Normung, GERMANY
fpm	Feet Per Minute
HST	Hydrostatic Transmission
Km/h	Kilometers Per Hour
MPH	Miles Per Hour
m/s	Meters Per Second
PTO	Power Take Off
RH/LH	Right-hand and left-hand sides are determined by facing in the direction of forward travel
ROPS	Roll-Over Protective Structures
rpm	Revolutions Per Minute
r/s	Revolutions Per Second
SAE	Society of Automotive Engineers, USA
VHT	Variable Hydro Transmission

UNIVERSAL SYMBOLS

As a guide to the operation of your vehicle, various universal symbols have been utilized on the instruments and controls. The symbols are shown below with an indication of their meaning.

	Safety Alert Symbol		Lift Cylinder-Retract
	Diesel Fuel		Lift Cylinder-Extend
	Hourmeter/Elapsed Operating Hours		Lift Cylinder-Float
	Engine Coolant-Temperature		Hazard Warning Lights
	Brake Fluid/Parking Brake		Headlight-Low Beam
	Engine Intake/Combustion Air-Filter		Headlight-High Beam
	Battery Charging Condition		Audible Warning Device
	Engine Oil-Pressure		Fast
	Turn Signal/Hazard/Trailer indicator		Slow
	Engine-Run		Lock
	Starter Control		Unlock
	Diesel Preheat/Glow Plugs(Low Temperature Start Aid)		
	Engine Shut-Off Control		
	Differential Lock		
	Differential Lock Hold		

FOREWORD

You are now the proud owner of a KUBOTA Vehicle. This vehicle is a product of KUBOTA quality engineering and manufacturing. It is made of excellent materials and under a rigid quality control system. It will give you long, satisfactory service. To obtain the best use of your vehicle, please read this manual carefully. It will help you become familiar with the operation of the vehicle and contains many helpful hints about vehicle maintenance. This manual contains instructions for minor maintenance, but information about major repairs is outlined in the KUBOTA Work Shop Manual and should be performed only by a KUBOTA Dealer Technician. It is KUBOTA's policy to utilize as quickly as possible every advance in our research. The immediate use of new techniques in the manufacture of products may cause some small parts of this manual to become outdated. KUBOTA distributors and dealers will have the most up-to-date information. Please do not hesitate to consult with them.



SAFETY FIRST

This symbol, the industry's "Safety Alert Symbol", is used throughout this manual and on labels on the machine itself to warn of the possibility of personal injury. Read these instructions carefully. It is essential that you read the instructions and safety regulations before you attempt to assemble or use this unit.



DANGER : Indicates an imminently hazardous situation which, if not avoided, will result in death or serious injury.



WARNING : Indicates a potentially hazardous situation which, if not avoided, could result in death or serious injury.



CAUTION : Indicates a potentially hazardous situation which, if not avoided, may result in minor or moderate injury.

IMPORTANT :

Indicates that equipment or property damage could result if instructions are not followed.

NOTE :

Gives helpful information.

CONTENTS

▲ SAFE OPERATION	1
SERVICING OF VEHICLE	1
SPECIFICATIONS	2
SPECIFICATION TABLE	2
TRAVELING SPEEDS	3
VEHICLE LIMITATIONS	4
INSTRUMENT PANEL AND CONTROLS	5
LOCATION OF PARTS	5
PRE-OPERATION CHECK	9
DAILY CHECK	9
OPERATING THE ENGINE	10
STARTING THE ENGINE	10
Cold Weather Starting	12
Block Heater	12
STOPPING THE ENGINE	13
WARMING UP	13
Warm-Up Transmission Oil in the Low Temperature Range	13
JUMP STARTING	14
OPERATING THE VEHICLE	15
OPERATING NEW VEHICLE	15
Do not Operate the Vehicle at Full Speed for the First 50 Hours	15
Changing Lubricating Oil for New Vehicles	15
STARTING	15
Operator's Seat	15
Seat Belt	16
Head Light Switch	16
Hazard Light Switch	16
Turn Signal Light Switch	17
Horn Button	17
Brake Pedal	18
Range Gear Shift Lever	18
4WD Lever	19
VHT Pressure Release Knob	19
Parking Brake Lever	20
Speed Control Pedal	20
STOPPING	20
Stopping	20
CHECK DURING DRIVING	20
Immediately Stop the Engine if:	20
Easy Checker(TM)	20
Fuel Gauge	21
Coolant Temperature Gauge	21
Hourmeter	21

Speedometer	22
PARKING	22
Parking Brake Lever	22
ACCESSORY	23
12V Electric Outlet	23
Rotating Beacon Light Outlet	23
Trailer Electrical Outlet	23
Utility Box	24
OPERATING TECHNIQUES	24
Differential Lock	24
Directions for Use of Power Steering	25
Unfamiliar Terrain	25
Driving in Reverse	26
Driving in "4WD"	26
Turning the Vehicle	27
Hills	27
Traversing Hillsides	28
Sliding and Skidding	28
Driving through Water	28
CARGO BED	29
CARGO BED	29
General Caution	29
Max. Cargo Load	29
Cargo Bed Tailgate	30
Raising and Lowering the Cargo Bed	31
TIRES AND WHEELS	32
TIRES	32
Inflation Pressure	32
Tire Type and Use	32
WHEELS	33
TOWING AND TRANSPORTING	34
TOWING AND TRANSPORTING	34
Rear Trailer Hitch	34
Front Coupling	34
Winch Mount Bracket [if equipped]	35
Transporting Vehicle	35
MAINTENANCE	36
SERVICE INTERVALS	36
LUBRICANTS, FUEL AND COOLANT	39
PERIODIC SERVICE	40
HOW TO OPEN THE HOOD AND TILT THE SEAT	40
Hood	40
Operator's Seat	40
HOW TO RAISE THE CARGO BED	41
Raising and Lowering the Cargo Bed	41
JACK-UP POINT	42
Front End	42
Rear End	42

DAILY CHECK	42
Walk Around Inspection	42
Checking and Refueling	42
Checking Engine Oil Level	43
Checking Transmission Fluid Level	44
Checking Power Steering Oil Tank Level	44
Checking Hydraulic Lift Oil Tank Level	45
Checking Coolant Level	45
Cleaning Radiator Screen	46
Checking Brake Fluid Level	46
Checking Brake Pedal	47
Checking Parking Brake	47
Checking Gauges, Meter and Easy Checker(TM)	47
Checking Head Light, Turn Signal Light etc.	47
Checking Seat Belt and ROPS	47
Checking Joint Boot	48
Checking Tire Inflation Pressure	49
Checking Backup Beeper	49
EVERY 50 HOURS	50
Greasing	50
Oiling	51
Checking Engine Start System	52
EVERY 100 HOURS	52
Checking VHT Neutral Spring	52
Checking Wheel Bolt Torque	52
Cleaning Air Cleaner Primary Element	53
Adjusting Alternator Belt Tension	53
Checking Fuel Line and Fuel Filter	54
Checking Battery Condition	55
Adjusting Toe-in	56
Cleaning Muffler	57
EVERY 200 HOURS	58
Adjusting Parking Brake	58
Replacing Engine Oil Filter	58
Changing Engine Oil	59
Replacing Transmission Oil Filter [HST]	60
Replacing Transmission Oil Filter [SUCTION]	61
Changing Hydraulic Lift Oil	62
Checking Brake Pedal	63
Checking Brake Hose and Pipe	63
Checking Front Brake Case	64
Checking Brake Light Switch	64
Checking Radiator Hose and Clamp	65
Checking Power Steering Line	65
Changing Power Steering Oil	66
Checking Intake Air Line	66
EVERY 300 HOURS	67
Checking Tire	67
EVERY 400 HOURS	67
Changing Knuckle Case Oil	67
Changing Transmission Fluid	68
Changing Front Axle Case Oil	69

EVERY 500 HOURS	69
Replacing Fuel Filter	69
EVERY 800 HOURS	69
Adjusting Engine Valve Clearance	69
EVERY 1500 HOURS	69
Checking Fuel Injection Nozzle Injection Pressure.....	69
EVERY 3000 HOURS	69
Checking Injection Pump	69
EVERY 1 YEAR	69
Replacing Air Cleaner Primary Element and Secondary Element.....	69
EVERY 2 YEARS	70
Changing Brake Fluid	70
Flush Cooling System and Changing Coolant.....	70
Anti-Freeze	71
Replacing Radiator Hose (Water pipes)	72
Replacing Power Steering Hose.....	72
Replacing Fuel Hose	72
Replacing Brake Master Cylinder (Inner Parts)	72
Replacing Front Brake Seal.....	72
Replacing Rear Brake Cylinder Seal	72
Replacing Intake Air Line.....	72
Replacing Remote Hydraulic Hose.....	72
EVERY 4 YEARS	72
Replacing Brake Hose	72
SERVICE AS REQUIRED.....	72
Bleeding Fuel System.....	72
Replacing Fuse.....	72
Replacing Slow-Blow Fuses	74
Replacing Light Bulb.....	74
STORAGE	75
VEHICLE STORAGE	75
REMOVING THE VEHICLE FROM STORAGE.....	75
TROUBLESHOOTING.....	76
ENGINE TROUBLESHOOTING	76
BATTERY TROUBLESHOOTING	77
MACHINE TROUBLESHOOTING	78



SAFE OPERATION

Careful operation is your best insurance against an accident.

Read and understand this Operator's Manual carefully before operating the vehicle.

All operators, no matter how much experience they may have, should read this and other related manuals before operating the vehicle or any implement attached to it. It is the owner's obligation to instruct all operators in safe operation.

1. BEFORE OPERATING THE VEHICLE

1. Know your equipment and its limitations. Read this entire manual before attempting to start and operate the vehicle.
2. Pay special attention to the Danger, Warning and Caution labels on the vehicle.
3. Do not remove Roll-Over Protective Structures (ROPS) for any application and fasten seat belts at all times. This combination will reduce the risk of serious injury or death, should the vehicle be upset. If the ROPS is loosened or removed for any reason, make sure that all parts are reinstalled correctly before operating the vehicle. Never modify or repair a ROPS because welding, bending, drilling, grinding, or cutting may weaken the structure. A damaged ROPS structure must be replaced, not repaired or revised. If any structural member of the ROPS is damaged, replace the entire structure at your local KUBOTA Dealer.

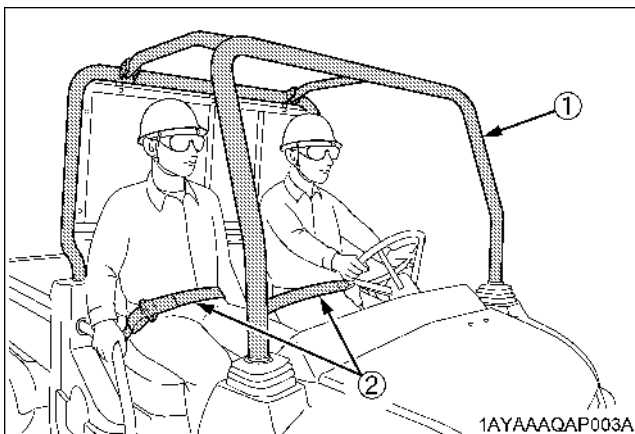

(1) ROPS
(2) Seat belt

4. Always use the seat belts. Check the seat belts regularly and replace if frayed or damaged.

5. Do not operate the vehicle or any implement attached to it while under the influence of alcohol, medication, controlled substances or while fatigued.
6. Carefully check the vicinity before operating the vehicle or any implement attached to it. Check for overhead clearance which may interfere with the ROPS. Do not allow any bystanders around or near the vehicle during operation.
7. Never allow anyone without a valid driver's license to operate this vehicle.
8. Before allowing other people to use your vehicle, explain how to operate and have them read this manual before operation.
9. Never wear loose, torn, or bulky clothing around the vehicle. It may catch on moving parts or controls, leading to the risk of an accident. Use additional safety items, e.g. helmet, safety boots or shoes, eye and hearing protection, gloves, etc., as appropriate or required.
10. In addition to the driver, only one passenger should ride in the vehicle.
Minimum age for passenger is 5 years old.
11. Keep all shields in place and stay away from all moving parts.
12. Check brakes, speed control pedal, and other mechanical parts for improper adjustment and wear. Replace worn or damaged parts promptly. Check the tightness of all nuts and bolts regularly. (For further details, see "MAINTENANCE" section.)
13. Keep your vehicle clean. Dirt, grease, and trash build up may contribute to fires and lead to personal injury.
14. Use only implements meeting the specifications listed under "VEHICLE LIMITATIONS" in this manual or implements approved by KUBOTA.
15. The maximum cargo capacity of this vehicle is 500kg. Reduce cargo capacity to match operating conditions. Do not carry anything which raises the center-of-gravity and sticks outside the cargo bed.
16. Do not modify the vehicle. Unauthorized modification may affect the function of the vehicle, which may result in personal injury.

2. OPERATING THE VEHICLE

◆ Starting

1. Always sit in the operator's seat when starting engine or operating levers or controls.
2. Before starting the engine, make sure that all levers are in their neutral positions and that the parking brake is engaged.
3. Do not start engine by shorting across starter terminals or bypassing the safety start switch. The vehicle may start in gear and move if normal starting circuitry is bypassed.
4. Be sure that the operator (and passenger) seat belts are fastened.
5. Do not operate or idle engine in a non-ventilated area. Carbon monoxide gas is colorless, odorless, and deadly.

◆ Operating

1. Do not wear headphones while operating.
2. Pull only from the trailer hitch. Never hitch to axle housing or any other point except trailer hitch; such arrangements will increase the risk of serious personal injury or death due to a vehicle upset.

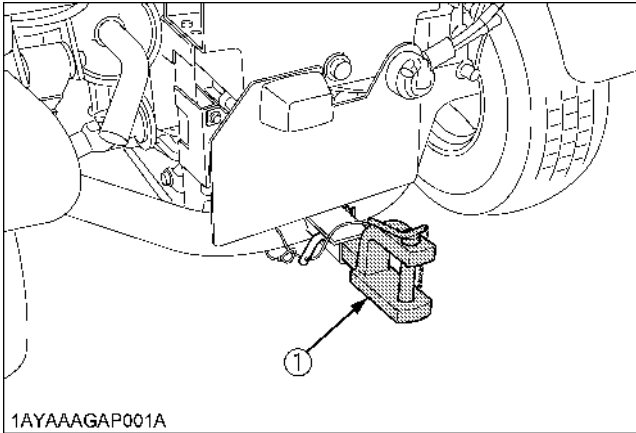

(1) Trailer hitch

3. Keep all shields and guards in place. Replace any that are missing or damaged.
4. Avoid sudden starts. To avoid rollovers, slow down when turning, on uneven ground, and before stopping.
5. The vehicle cannot turn with the differential locked and attempting to do so could be dangerous.
6. Do not operate near ditches, holes, embankments, or other ground surface features which may collapse under the vehicle's weight. The risk of vehicle upset is even higher when the ground is loose or wet.
7. Watch where you are going at all times. Watch for and avoid obstacles. Be alert at row ends, near trees, and other obstructions.
8. When working in groups, always let the others know what you are going to do before you do it.
9. Never try to get on or off a moving vehicle.

◆ Safety for children

Tragedy can occur if the operator is not alert to the presence of children. Children generally are attracted to vehicles and the work they do.

1. Never assume that children will remain where you last saw them.
2. Keep children out of the work area and under the watchful eye of another responsible adult.
3. Be alert and shut your vehicle down if children enter the work area.
4. Never carry children in the cargo bed. There is no safe place for them to ride. No person under the age of 5 may ride as a passenger in this vehicle. A passenger under 5 years of age requires special restraints which are not available with this vehicle.
5. Never allow children to operate the vehicle even under adult supervision.
6. Never allow children to play on the vehicle or on the implement.
7. Use extra caution when backing up. Look behind and down to make sure area is clear before moving.
8. Whenever possible, park your vehicle on a firm, flat and level surface. If this is not possible, park it across the slope. Set the parking brake(s), lower the implements to the ground, remove the key from the ignition and chock the wheels.

◆ Operating on slopes

Slopes are a major factor related to loss-of-control and tip-over accidents, which can result in severe injury or death. All slopes require extra caution.

1. Travel straight up or down hill.
2. Reduce load when operating on hilly or over rough terrain.
3. Keep front wheels straight at crest of hill or going over bumps.
4. Do not stop or start suddenly when going uphill or downhill. Be especially cautious when changing direction on slopes.
5. If vehicle stops or loses power going up a hill, lock parking brake to hold vehicle on slope. Maintain direction of travel and release brake slowly. Back straight downhill while maintaining control. Do not turn vehicle sideways. Vehicle is more stable in a straight forward or rearward position.
6. When riding on soft terrain, turn front wheels slightly uphill to keep vehicle on a straight line across the hill.
7. If the vehicle begins to tip, turn front wheels downhill to gain control before proceeding.
 - (1) To avoid upsets, always back up steep slopes. If you cannot back up the slope or if you feel uneasy on it, do not operate on it. Stay off slopes too steep for safe operation.

- (2) Driving forward out of a ditch, mired condition or up a steep slope increases the risk of a vehicle to be upset backward. Always back out of these situations. Extra caution is required with four-wheel drive mode because the increased traction can give the operator false confidence in the vehicle's ability to climb slopes.
- (3) Keep all movement on slopes slow and gradual. Do not make sudden changes in speed or direction.

◆ Operation in inclement conditions

1. Only operate during daylight or with good artificial light.
2. Operate vehicle in an open, unobstructed area.
3. Use helmet and/or protective gear for certain operating conditions.
4. Reduce speed according to trail, terrain and visibility conditions.
5. Never drive exceeding the limit of visibility. Slow down near crest of hill until getting a clear view of the other side.
6. Stay alert for holes, rocks and other hidden hazards in the terrain.
7. Never cross any body of water where depth may be unknown to the operator (Deep water is considered anything in excess the bottom edge of the axle cap). Choose a course within the waterway where both banks have a gradual incline. Cross at a point known to be safe.

◆ Driving the vehicle at high speeds

1. Check the front wheel engagement. The braking characteristics are different between two and four wheel drive. Be aware of the difference and use carefully.
2. Always slow the vehicle down before turning. Turning at high speed may tip the vehicle over.
3. Turn the headlights on.
4. Drive at speeds that allow you to maintain control at all times.
5. Do not apply the differential lock while traveling at high speeds. The vehicle may run out of control.
6. Avoid sudden motions of the steering wheel as they can lead to a dangerous loss of stability. The risk is especially great when the vehicle is traveling at high speeds.

◆ Other miscellaneous

1. Clean platform if dirty and remove any debris from around foot controls.
2. Always keep both hands on the steering wheel.
3. Always keep arms and legs inside the operating compartment.
4. Never operate the vehicle while standing.
5. Do not tow a cart with any riders on it.
6. Never attempt wheelies, jumps or other stunts.

3. HAULING LOADS IN THE CARGO BED

1. No riders in cargo bed or anywhere else.
2. Do not overload vehicle. Securely anchor all loads.
3. Be sure load is evenly distributed.
4. Reduce cargo capacity when operating on rough or hilly terrain.
5. Balance loads evenly and secure them. Braking could shift the load and affect vehicle stability.
6. Never operate vehicle with the cargo bed raised.
7. Operate cargo bed dump with vehicle stationary and parking brake locked. Do not dump while moving.
8. Operate hydraulic dump on level ground only.
9. Operate dump from operator's seat only.
10. Do not place hands or body under the cargo bed when lowering bed.

4. PARKING THE VEHICLE

1. Lower all implements to the ground, place all control levers in their neutral positions, set the parking brake, stop the engine, and remove the key.
2. Make sure that the vehicle has come to a complete stop before dismounting.
3. Avoid parking on steep slopes, if possible park on flat ground, if not, park across a slope, always with attachment on the ground.

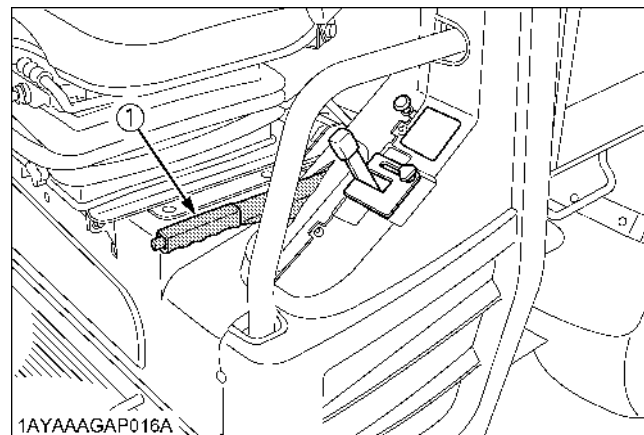

(1) Parking brake lever

5. TRANSPORTING

1. Do not tow this vehicle. Use a suitable truck or trailer when transporting on public roads.
2. Use extra care when loading or unloading the vehicle into a trailer or truck.

6. SERVICING THE VEHICLE

Before servicing the vehicle, park it on a firm, flat and level surface, set the parking brake, lower all implements to the ground, place the range gear shift lever in neutral, stop the engine and remove the key.

1. Allow the vehicle time to cool off before working on or near the engine, muffler, radiator, etc.
2. Always stop the engine before refueling. Avoid spills and overfilling.
3. Do not smoke when working around battery or when refueling. Keep all sparks and flames away from battery and fuel tank. The battery presents an explosive hazard, because it gives off hydrogen and oxygen especially when recharging.
4. Before "jump starting" a dead battery, read and follow all of the instructions. (See "JUMP STARTING" in "OPERATING THE ENGINE" section.)
5. Keep first aid kit and fire extinguisher handy at all times.
6. Disconnect the battery's ground cable before working on or near electric components.
7. To avoid the possibility of battery explosion, do not use or charge the refillable type battery if the fluid level is below the LOWER (lower limit level) mark. Check the fluid level regularly and add distilled water as required so that the fluid level is between the UPPER and LOWER marks.
8. To avoid sparks from an accidental short circuit, always disconnect the battery's ground cable (-) first and reconnect it last.

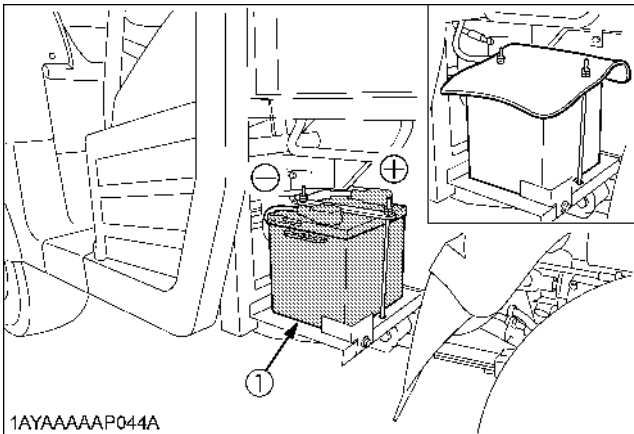

1AYAAAAAP044A

(1) Battery

9. Do not remove radiator cap while coolant is hot. When cool, slowly rotate cap to the first stop and allow sufficient time for excess pressure to escape before removing the cap completely. If the vehicle has a coolant recovery tank, add coolant or water to the tank, not the radiator. (See "Checking Coolant Level" in "DAILY CHECK" in "PERIODIC SERVICE" section.)

10. Do not attempt to mount a tire on a rim. This should be done by a qualified person with the proper equipment.
11. Always maintain the correct tire pressure. Do not inflate tires above the recommended pressure shown in the operator's manual.

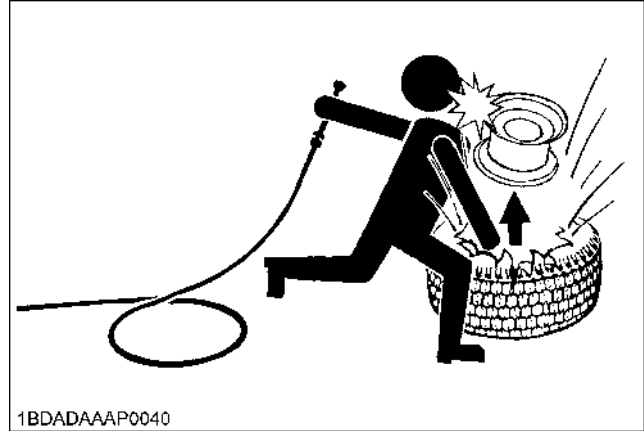

1BDADAAAP0040

12. Securely support the vehicle when changing wheels.
13. Make sure that wheel bolts have been tightened to the specified torque.
14. Do not work under any hydraulically supported devices. They can settle, suddenly leak down, or be accidentally lowered. If it is necessary to work under the vehicle or any vehicle elements for servicing or adjustment, securely support them with stands or suitable blocking beforehand.
15. Escaping hydraulic fluid under pressure has sufficient force to penetrate skin causing serious personal injury. Before disconnecting hydraulic lines, be sure to release all residual pressure. Before applying pressure to the hydraulic system, make sure that all connections are tight and that all lines, pipes, and hoses are free of damage.
"High pressure fluid - Injection into body" hazard warning.

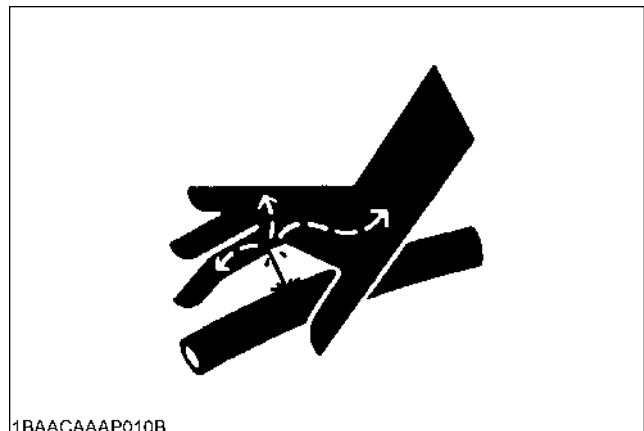

1BAACAAAP010B

16. Fluid escaping from pinholes may be invisible. Do not use hands to search for suspected leaks; use a piece of cardboard or wood. Use of safety goggles or other eye protection is also highly recommended. If injured by escaping fluid, see a medical doctor at once. This fluid will produce gangrene or severe allergic reaction.

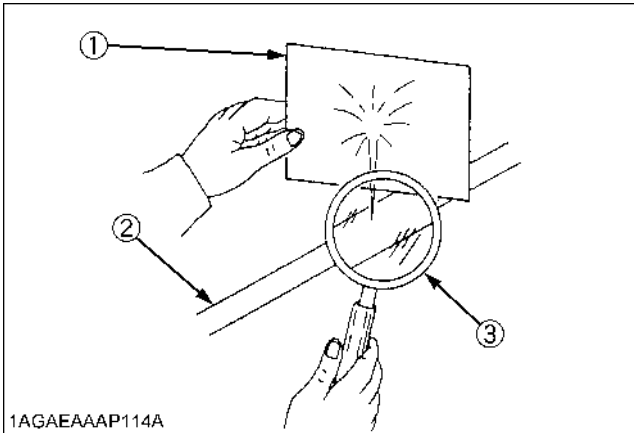

- (1) Cardboard
- (2) Hydraulic line
- (3) Magnifying glass

17. Waste products such as used oil, fuel, hydraulic fluid, and batteries, can harm the environment, people, pets and wildlife. Please dispose properly. See your local Recycling Center or KUBOTA Dealer to learn how to recycle or get rid of waste products.

7. PICTORIAL SAFETY LABELS

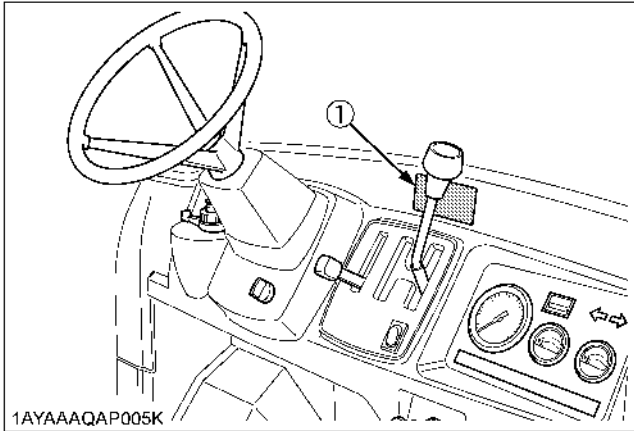

(1) Part No. K7583-6522-1

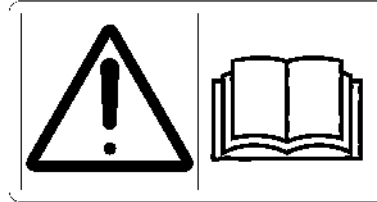

1AYAACHAP001A

THIS LABEL INCLUDE 7 POINTS CAUTIONS BELOW.**Ⓐ GENERAL CAUTIONS**

1. Read and understand the operator's manual before operation.
2. Never allow anyone without a valid driver's license to operate this vehicle.
3. Before allowing other people to use the vehicle, have them read the operator's manual.
4. Wear safety gear, including helmet and eye protection, as appropriate.
5. Check the tightness of all nuts and bolts regularly.
6. In addition to the driver, only one passenger can be carried. Minimum age for passenger is five years old.
7. Before starting the engine, make sure that everyone is at a safe distance from the vehicle.
8. Do not operate the vehicle under the influence of drugs or alcohol.
9. Keep all shields in place and stay away from all moving parts.
10. Slow down for turns, or rough terrain.
11. Before getting off from the vehicle, apply the parking brake, stop the engine and remove the key.

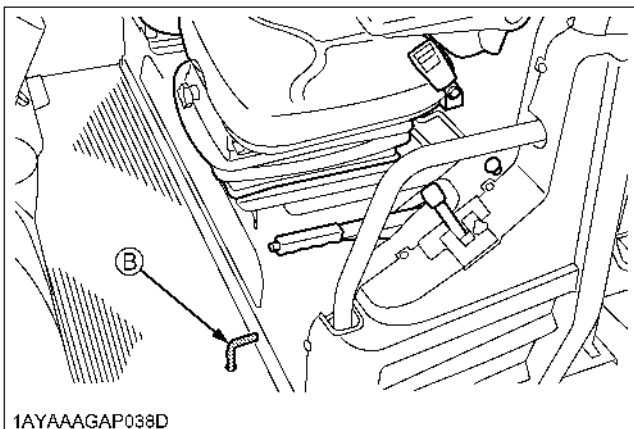
**Ⓑ DIFFERENTIAL LOCK PEDAL**

- Do not depress the differential lock pedal at high speed.

1AYAACKAP008A

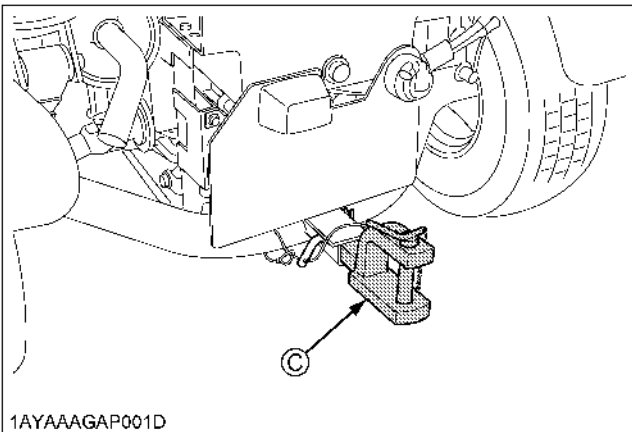

Ⓒ REAR TRAILER HITCH

- Attach pulled or towed loads to the drawbar only.

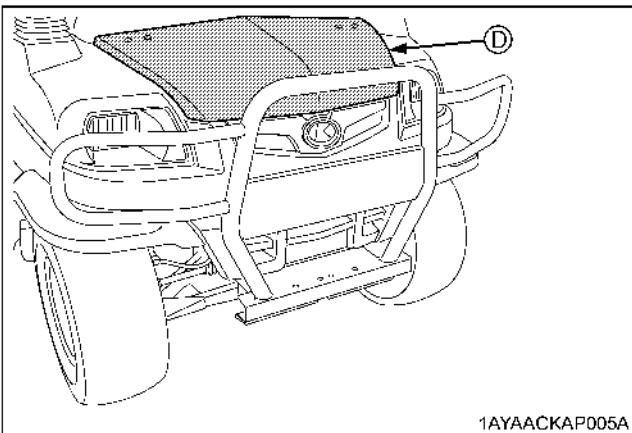

Ⓓ FRONT HOOD

- Do not operate the vehicle with the front hood open. Impaired visibility of the operator may cause loss of vehicle control.
- Latch the hood securely before operating the vehicle.

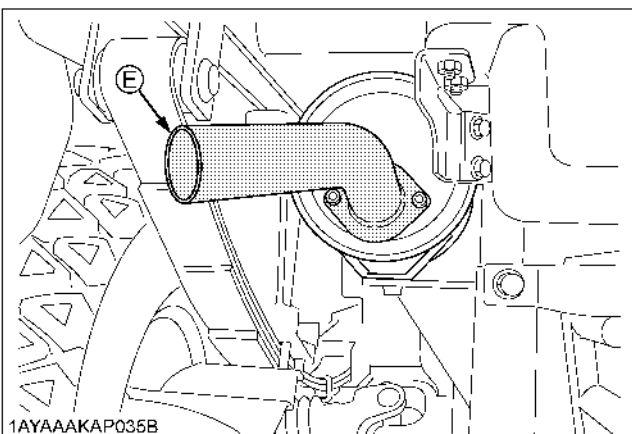

Ⓔ SPARK ARRESTER

1. Before touching any part of an exhaust system, be absolutely sure that it has had sufficient time to cool.
2. Always wear safety goggles and a (face)mask.
3. The particulate matter contained in the muffler contains chemicals that are harmful to people, animal and marine life.
4. If you are unable to do this work, have it done by your KUBOTA Dealer.

1AYAAACKAP009A

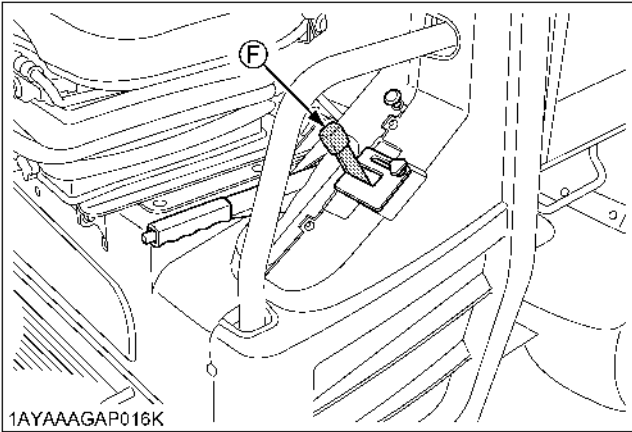
**F HYDRAULIC LIFT CYLINDER LEVER**

1. Do not utilize the lever lock for machine maintenance or repair.
2. The lever lock is to prevent accidental actuation.

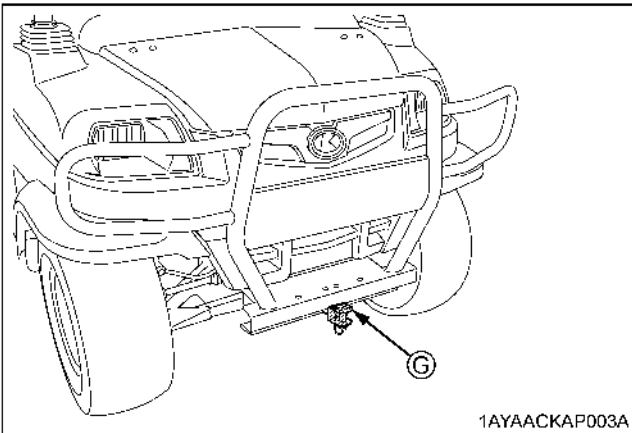
**G FRONT COUPLING**

- Attach pulled or towed loads to the drawbar only.

1AYAACKAP010A

(1) Part No. K7583-6524-1

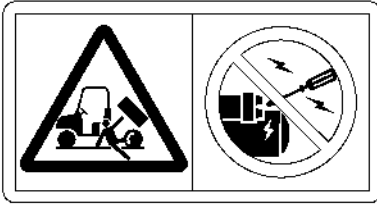

1AYAACHAP002A

1. Do not start engine by shorting across starter terminals or bypassing the safety start switch. The vehicle may start in gear and move if normal starting circuitry is bypassed.
2. Start engine only from operator's seat with range shift lever in neutral position.

(2) Part No. K7583-6526-1

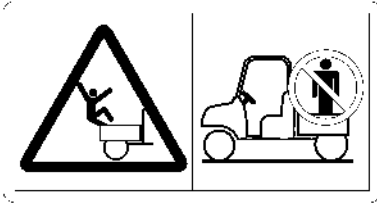

1AYAACHAP005A

1. Do not carry passengers in cargo bed.
2. Do not travel with the cargo bed in the raised position.

(3) Part No. K7583-6544-1



1AYAACHAP006A

- Always use the safety support or propping rod when working near a raised cargo bed or attachment.

(4) Part No. K7583-6541-1

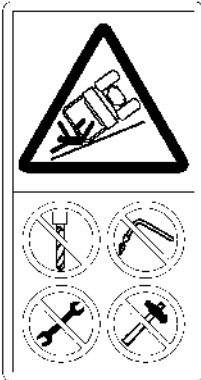

1AYAACHAP009A

1. Do not remove Roll-Over Protective Structures (ROPS) for any application.
2. Do not modify or repair a ROPS because welding, grinding, drilling or cutting any portion may weaken the structure.

(5) Part No. K7583-6551-1

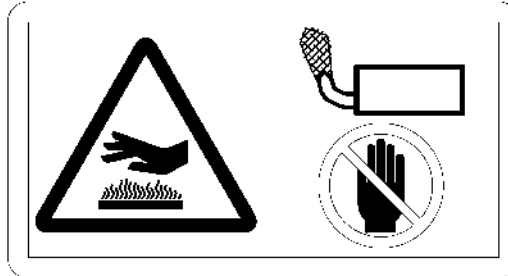

1AYAACHAP011A

- Hot surface - Burn to finger or hand
- Do not touch muffler.

(6) Part No. K7583-6550-1



1AYAACHAP008A

- Do not get your hands close to engine fan and fan belt.

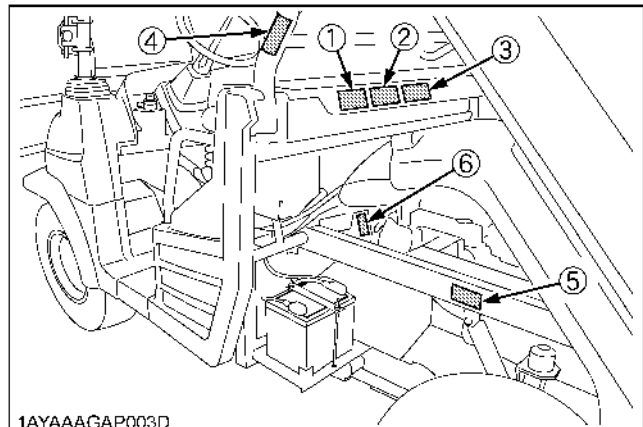

1AYAAAGAP003D

1AYAACKAP011A

(1) Part No. K7583-6565-1

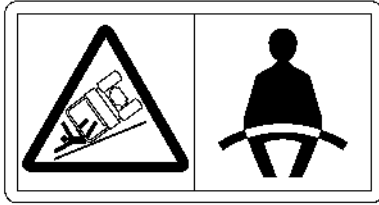

1AYAACHAP003A

- Always fasten your seat belt on drivers seat and passenger seat.

(2) Part No. K7583-6537-1



1AYAACHAP004A

- DIESEL FUEL ONLY
- NO FIRE

(3) Part No. K7583-6560-1



1AYAACHAP008A

- Do not get your hands close to engine fan and fan belt.

(4) Part No. K7583-6551-1



1AYAACHAP011A

- Hot surface-Burn to finger or hand
- Do not touch muffler.

(5) Part No. K1221-6118-1

MAINTENANCE FREE • SANS ENTRETIEN • LIBRE DE MANTENIMIENTO

⚠ DANGER/POISON ¡PELIGRO/VENENO!

<p>SHIELD EYES. EXPLOSIVE GASES CAN CAUSE BLINDNESS OR INJURY.</p> <p>PROTEGEZ LES YEUX. LES BAZ EXPLOSIFS PEUVENT BLESSEZ OU RENDRE AVEUGLE.</p> <p>PROTEJA LOS OJOS. LOS GASES EXPLOSIVOS PUEDEN CAUSAR DAÑOS O CEGUERA.</p>	<p>NO SPARKS / FLAMES / SMOKING</p> <p>ÉVITER • LES ÉTINCELLES • LES FLAMMES • DE FUMER</p> <p>NO • CHISPAS • FLAMAS • CIGARROS</p>	<p>SULFURIC ACID CAN CAUSE BLINDNESS OR SEVERE BURNS.</p> <p>L'ACIDE SULFURIQUE PEUT CAUSER LA CÉCITÉ OU DES BRÛLURES GRAVES.</p> <p>ACIDO SULFURICO PUEDE CAUSAR CEGUERA O QUEJADURAS FUERTES.</p>	<p>FLUSH EYES IMMEDIATELY WITH WATER. GET MEDICAL HELP FAST.</p> <p>RINCEZ LES YEUX A L'EAU IMMEDIATEMENT CONSULTEZ UN MEDECIN RAPIDEMENT.</p> <p>ENRIAGUE LOS OJOS INMEDIATAMENTE CON AGUA. ACUDA RAPIDO CON EL MEDICO.</p>
---	--	--	---

KEEP OUT OF THE REACH OF CHILDREN. DO NOT TIP. DO NOT OPEN BATTERY!
 TENIR HORS DE LA PORTEE DES ENFANTS. NE PAS RENVERSEZ. NE PAS OUVRIR LA BATTERIE!
 ALEJISE DEL ALCANCE DE LOS NIÑOS. NO VOLTEAR. NO ABRIR LA BATERIA!

CALIFORNIA PROPOSITION 65 WARNING: Batteries, battery packs, terminals and related accessories contain lead and lead compounds, and other chemicals known to the State of California to cause cancer and birth defects or other reproductive harm. WASH HANDS AFTER HANDLING.

Dist. by/por:par: EPM Products, Baltimore, MD 21226

MADE IN U.S.A. FABRIQUE AUX E.U.A. HECHO EN E.U.A.

Pb

1BDADAIAIP280

- SHIELD EYES
EXPLOSIVE GASES can cause blindness or injury.
- NO SPARKS / FLAMES / SMOKING
- SULFURIC ACID can cause blindness or severe burns.
- Flush eyes immediately with water.
- Get medical help fast.

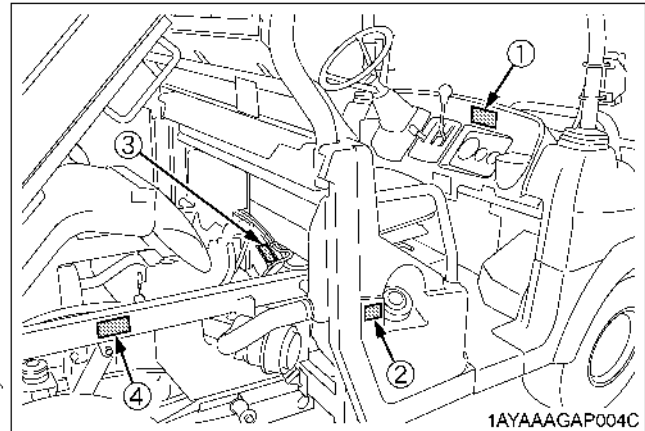

1AYAAAGAP004C

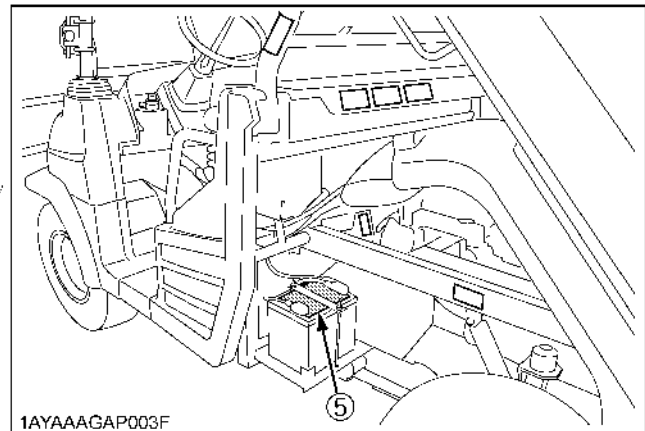

1AYAAAGAP003F

1AYAACKAP012A

(1) Part No. K7583-6546-1



1AYAAACHAP010A

1. Use brake fluid (DOT-3) only.
Other oil types will ruin synthetic resin or rubber installed in brake system components, and cause brake failure.
2. If brake fluid is spilled on power steering hose, wash off with water immediately.
Brake fluid quickly ruins synthetic resin or rubber hoses.

(2) Part No. K7583-6563-1

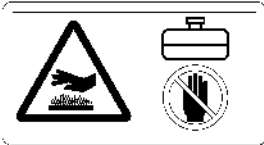

1AYAAACHAP007A

- Hot surface-Burn to finger or hand
- Do not touch tank.

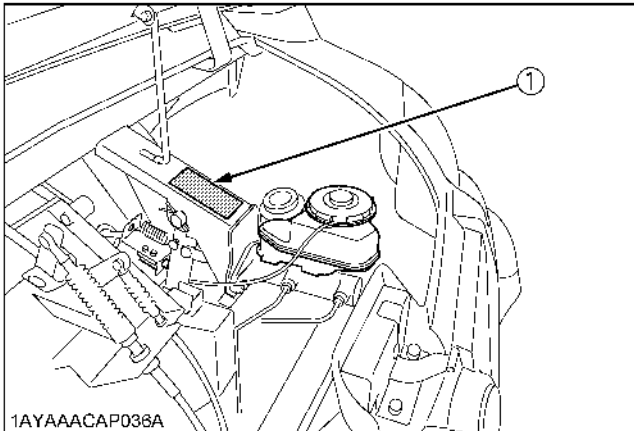

1AYAAACAP038A

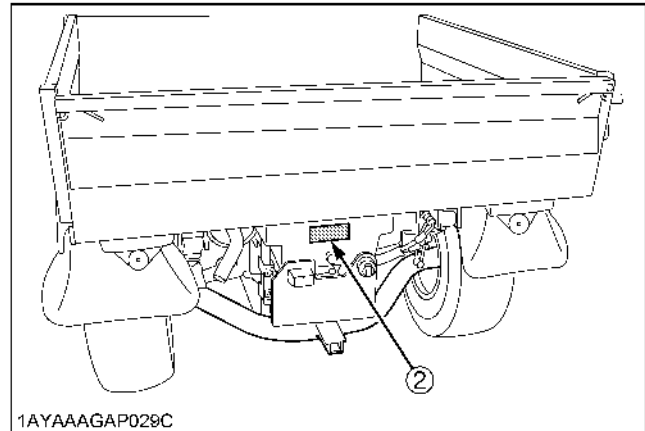

1AYAAAGAP029C

1AYAAACKAP013A

8. CARE OF PICTORIAL SAFETY LABELS

1. Keep pictorial safety labels clean and free from obstructing material.
2. Clean pictorial safety labels with soap and water, dry with a soft cloth.
3. Replace damaged or missing pictorial safety labels with new labels from your local KUBOTA Dealer.
4. If a component with pictorial safety label(s) affixed is replaced with new part, make sure new label(s) is (are) attached in the same location(s) as the replaced component.
5. Mount new pictorial safety labels by applying on a clean dry surface and pressing any bubbles to outside edge.

SERVICING OF VEHICLE

Your dealer is interested in your new vehicle and has the desire to help you get the most value from it. After reading this manual thoroughly, you will find that you can do some of the regular maintenance by yourself.

However, when in need of parts or major service, be sure to see your KUBOTA Dealer.

For service, contact the KUBOTA Dealership from which you purchased your vehicle or your local KUBOTA Dealer.

When in need of parts, be prepared to give your dealer both the vehicle and engine serial numbers.

Locate the serial numbers now and record them in the space provided.

	Type	Serial No.
Vehicle		
Engine		
Date of Purchase		
Name of Dealer (To be filled in by purchaser)		

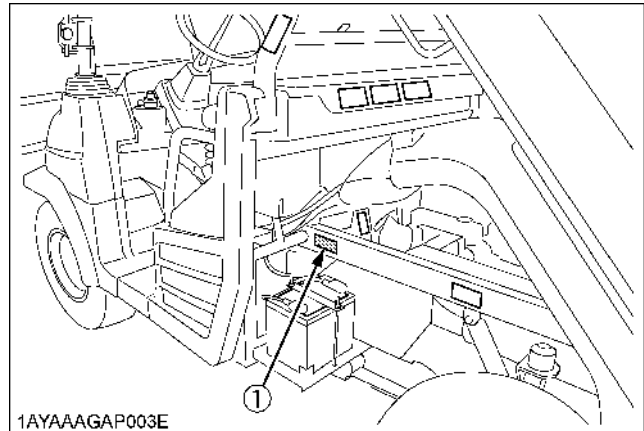

(1) Vehicle identification plate

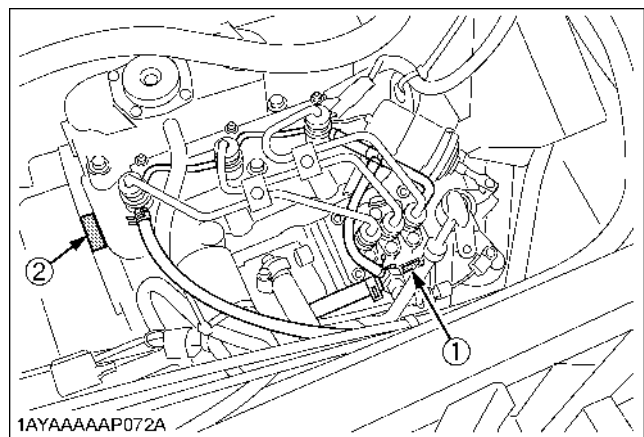

(1) Engine serial number
(2) Transmission assy serial number

SPECIFICATIONS

SPECIFICATION TABLE

Model			Worksite	Recreational	
Engine	Make		KUBOTA D902-E3-UV		
	Type		3 cylinders, 4-cycle, diesel, OHV		
	Displacement	L	0.898		
	Horsepower	kW / rpm	16.1 / 3200		
Fuel Capacity		L	28		
Transmission			Continuously variable hydro transmission (VHT)		
Wheels, Drive system			4, Rear 2WD or 4WD		
Differential lock			Standard; foot operated with mechanical holder		
Gear selection			Hi-Med-Lo range forward, neutral, reverse		
Brakes	Front / Rear		Wet disk brake		
	Parking brake		Rear wheel, hand lever		
Steering			Hydrostatic power		
Suspension	Front		Independent, macpherson strut-type		
	Rear		Semi-independent, DeDion axle w/leaf springs and shock absorber		
Dimensions	Length	mm	3120		
	Width	mm	1550		
	Height, overall	mm	2125		
	Front tread centers	mm	1150		
	Rear tread centers	mm	1180		
	Wheelbase	mm	1965		
	Ground clearance	front axle	mm	240	
		rear axle		205	
Turning diameter	m	8.3			
Max. rolling weight (Towing Capacity)		kg	590		
Payload capacity		kg	695	690	
Weight		kg	925	930	
Cargo bed	Width	mm	1320		
	Length	mm	1180		
	Depth	mm	290		
	Volume	m ³	0.455		
	Bed height (unloaded)	mm	805		
	Cargo bed load	kg	500		

Model		Worksite	Recreational
Surrounding noise level (static)	db (A)	78.6	
Tires	Front	25 x 10 - 12 HDWS, 6PLY	25 x 10 - 12 ATV, 6PLY (for U.K.) 25 x 10 - 12 HDWS, 6PLY (except for U.K.)
	Rear	25 x 10 - 12 HDWS, 6PLY	25 x 11 - 12 ATV, 6PLY (for U.K.) 25 x 10 - 12 HDWS, 6PLY (except for U.K.)
Front deluxe guard		Std.	
Body color		Orange	Camo
Bed lift		Std.	
Speedometer		Std.	

NOTE :

- The company reserves the right to change the specifications without notice.
- The values in "Ground clearance" and "Weight" are those of the machine equipped with the tires in the table above.

TRAVELING SPEEDS

Model	Worksite	Recreational
Tire size (Rear)	25 x 10 - 12 HDWS	25 x 11 - 12 ATV (for U.K.) 25 x 10 - 12 HDWS (except for U.K.)
Range gear shift lever	km/h	
Low	16	
Medium	29	
High	40	
Reverse	20	

VEHICLE LIMITATIONS

The KUBOTA Vehicle has been thoroughly tested for proper performance with implements sold or approved by KUBOTA. Use with implements which are not sold or approved by KUBOTA and which exceed the maximum specifications listed below, or which are otherwise unfit for use with the KUBOTA Vehicle may result in malfunctions or failures of the vehicle, damage to other property and injury to the operator or others. [Any malfunctions or failures of the vehicle resulting from use with improper implements are not covered by the warranty]

Max. Cargo loading weight (W1)	Rear trailer hitch	Front coupling
Max. Cargo load should not exceed "500 kg" or "PCL". [Worksite model] PCL = 695 kg - (operator + passenger + opt. + acc. + cabin) weight [Recreational model] PCL = 690 kg - (operator + passenger + opt. + acc. + cabin) weight PCL: Permissible Cargo Load opt.: option acc.: accessory	Max. rolling weight (W2) 590 kg	Max. rolling weight (W4) 295 kg
	Max. tongue weight (W3) 50 kg	Max. tongue weight (W5) 50 kg

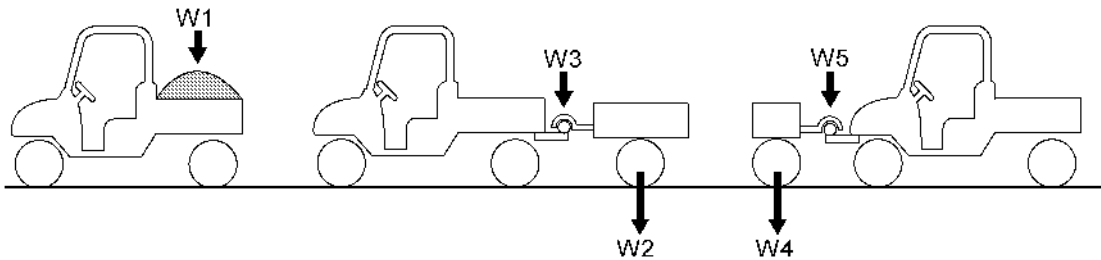

1AYAAAAAP092A

Rolling weight: Trailer weight + Cargo Load

- Above mentioned specifications are based on level ground condition.

INSTRUMENT PANEL AND CONTROLS

LOCATION OF PARTS

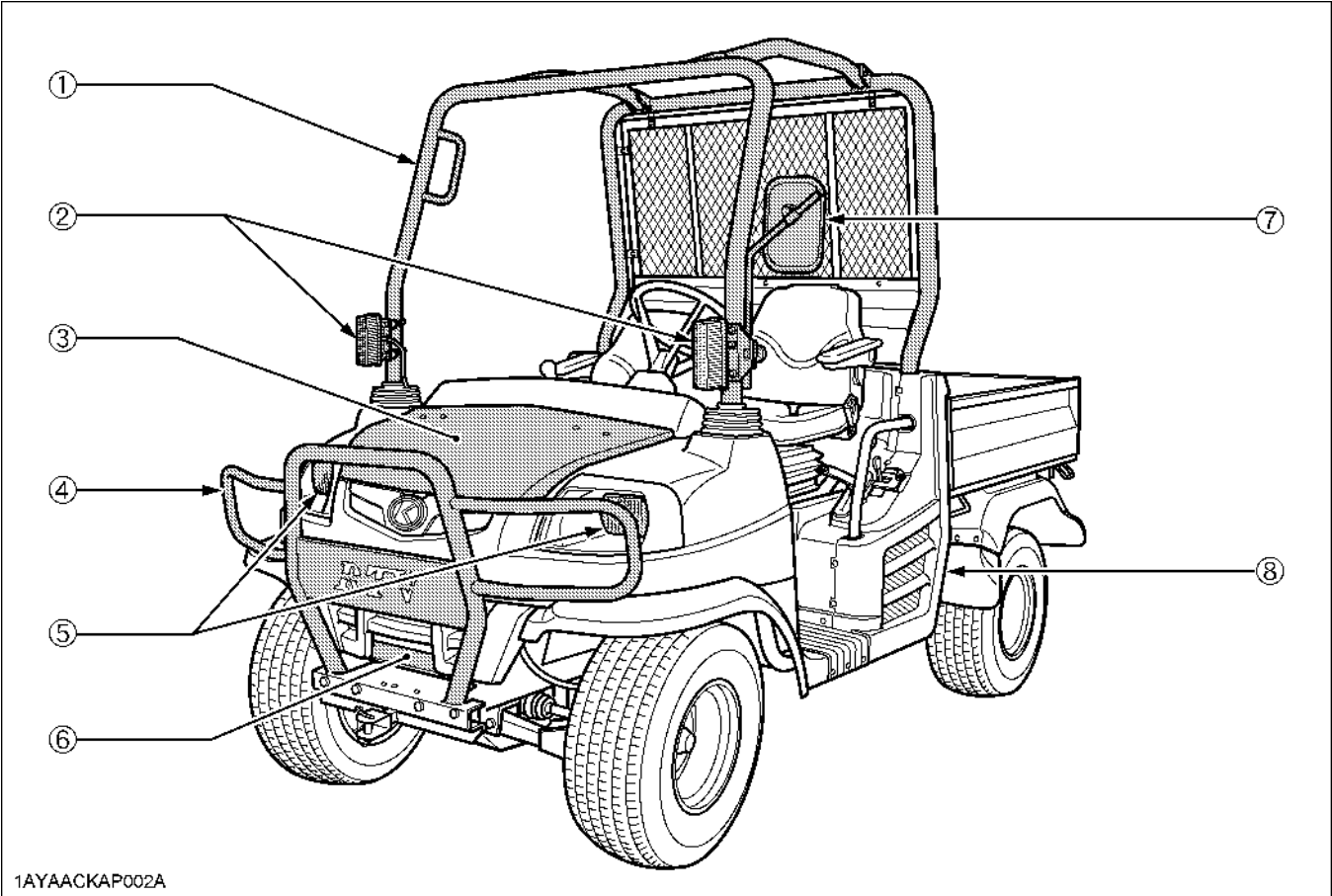

1AYAACKAP002A

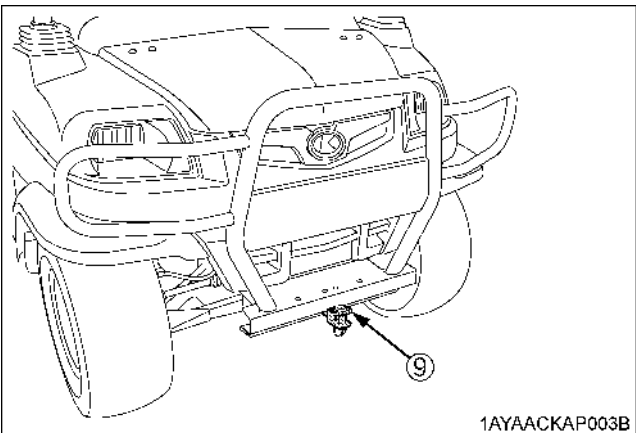

1AYAACKAP003B

ILLUSTRATED CONTENTS

(1) ROPS.....	--
(2) Hazard / Turn signal / Side marker light.....	16, 17
(3) Front hood.....	40
(4) Front guard.....	--
(5) Headlights.....	16
(6) Winch mount bracket (if equipped).....	35
(7) Rear view mirror.....	--
(8) Battery.....	55
(9) Front coupling.....	34

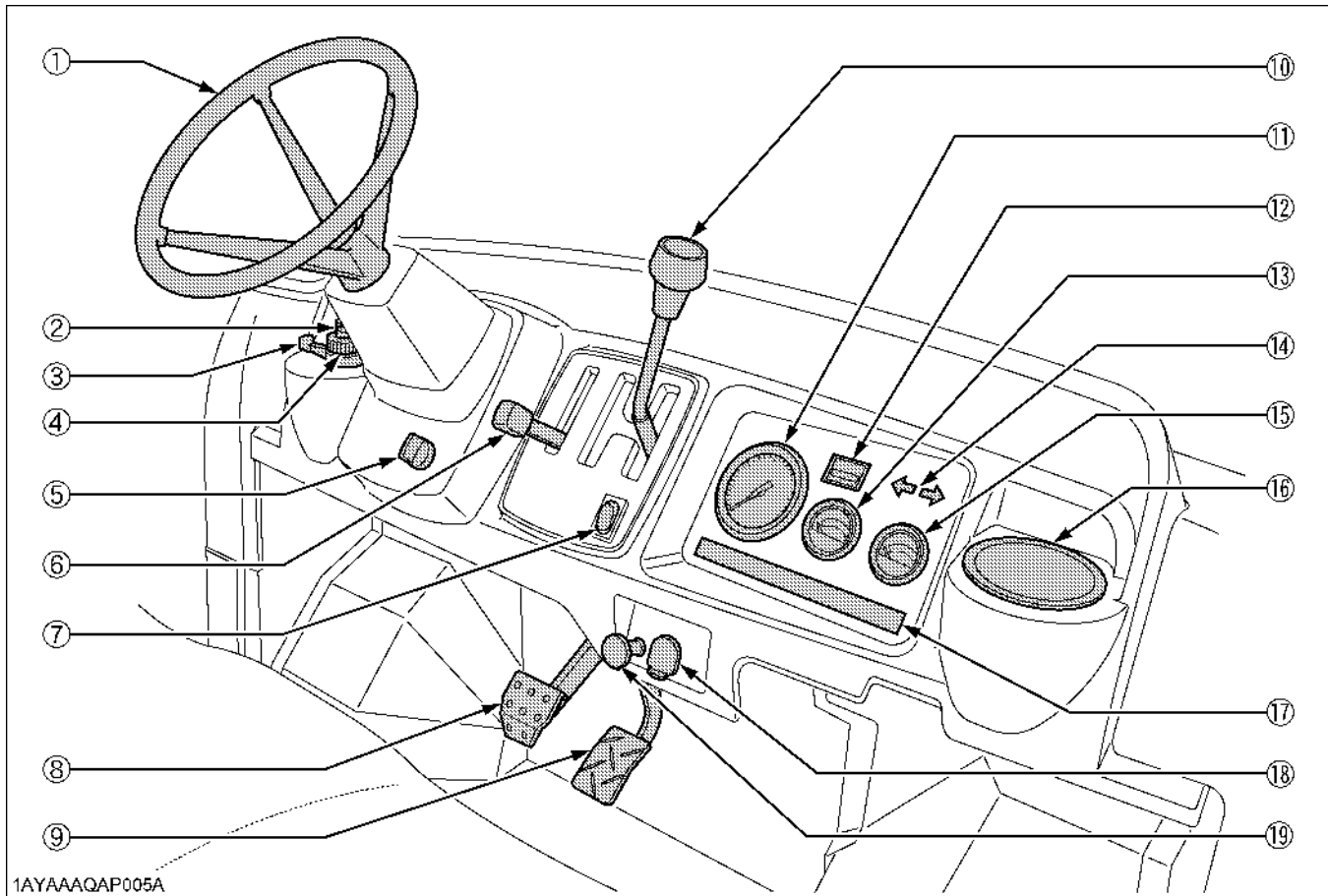

1AYAAAQAP005A

ILLUSTRATED CONTENTS

ILLUSTRATED CONTENTS

(1) Steering wheel.....	--
(2) Horn button.....	17
(3) Turn signal light switch.....	17
(4) Head light switch.....	16
(5) Key switch.....	--
(6) 4WD lever.....	19
(7) Hazard light switch.....	16
(8) Brake pedal.....	18
(9) Speed control pedal.....	20

(10) Range gear shift lever.....	18
(11) Speedometer.....	22
(12) Hourmeter.....	21
(13) Coolant temperature gauge.....	21
(14) Hazard / Turn signal indicator.....	16, 17
(15) Fuel gauge.....	21
(16) Cup holder.....	--
(17) Easy Checker(TM).....	20
(18) 12V accessory plug.....	--
(19) VHT pressure release knob.....	19

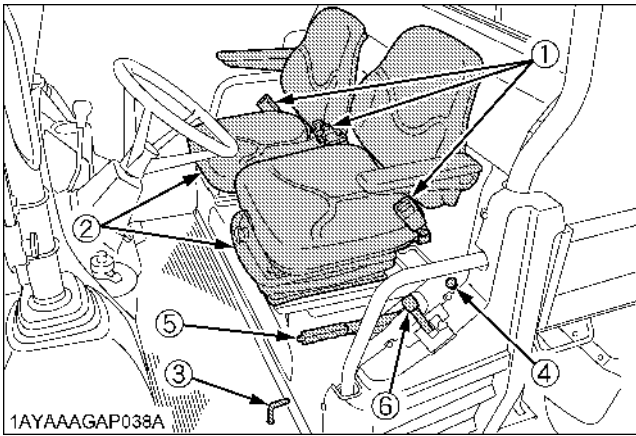

ILLUSTRATED CONTENTS

(1) <i>Seat belts</i>	16
(2) <i>Seat</i>	40
(3) <i>Differential lock pedal</i>	24
(4) <i>Differential lock holder</i>	24
(5) <i>Parking brake lever</i>	20
(6) <i>Hydraulic lift cylinder lever</i>	31

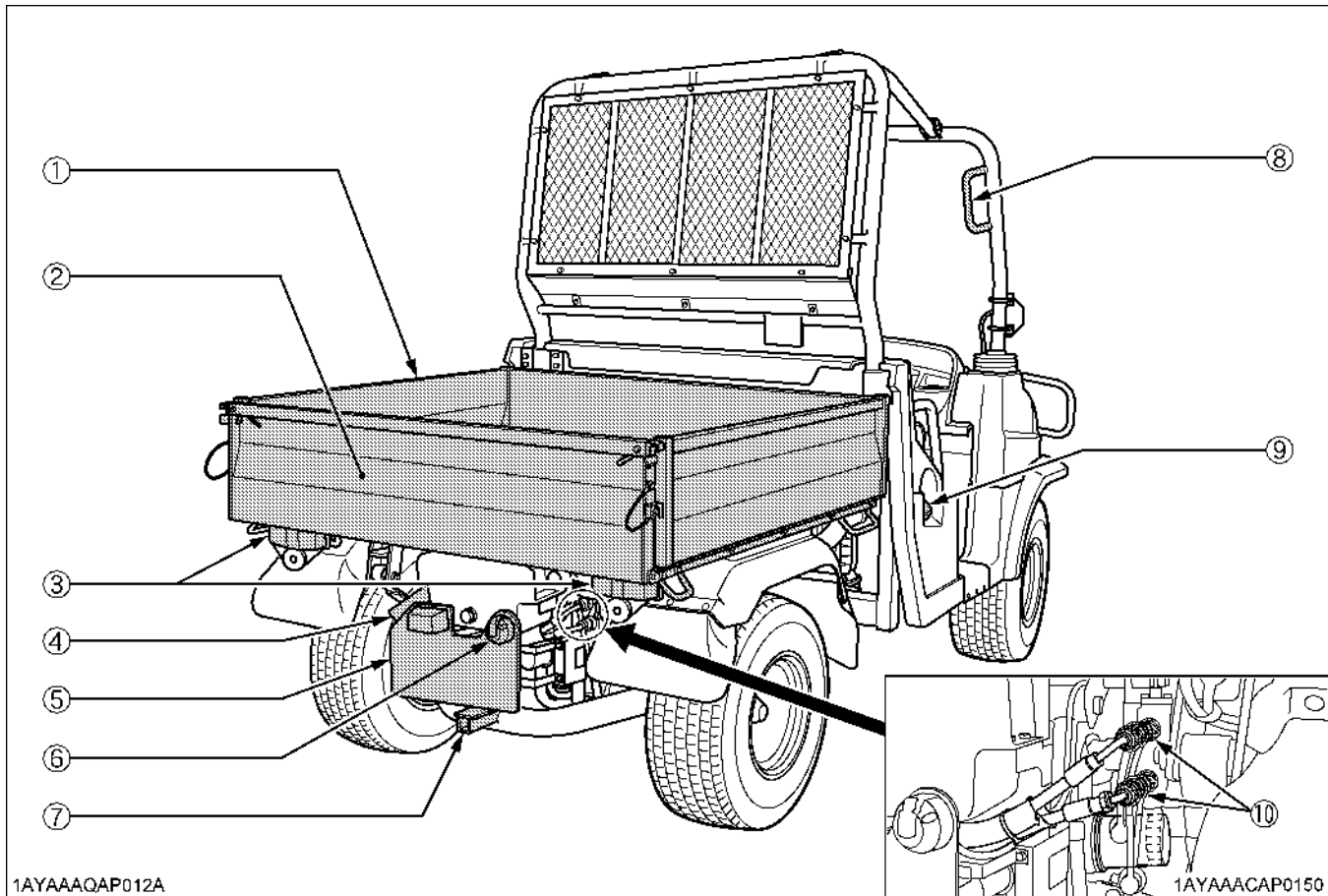

1AYAAAQAP012A

1AYAAACAP0150

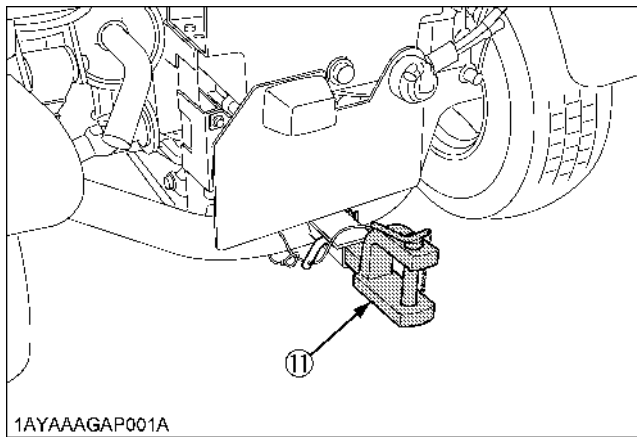

1AYAAAQAP001A

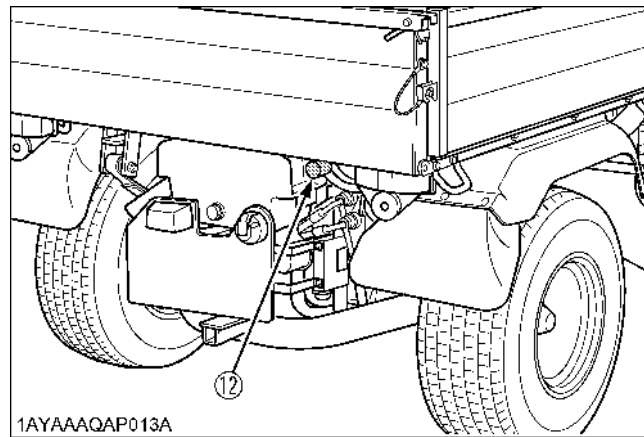

1AYAAAQAP013A

ILLUSTRATED CONTENTS

(1) Cargo bed.....	29
(2) Tailgate.....	30
(3) Combination lamp (Tail / Brake stop / Rear turn signal / Hazard light).....	16, 17
(4) Muffler.....	57
(5) Number plate.....	--
(6) Trailer electrical outlet.....	23

ILLUSTRATED CONTENTS

(7) Rear trailer hitch bracket.....	34
(8) Handgrip.....	--
(9) Fuel tank cap.....	42
(10) Hydraulic outlet for lift cylinder.....	31
(11) Rear trailer hitch.....	34
(12) Backup beeper (if equipped).....	49

PRE-OPERATION CHECK

DAILY CHECK

To prevent trouble from occurring, it is important to know the condition of the vehicle well. Check it before starting.



CAUTION

To avoid personal injury:

- **Be sure to check and service the vehicle on a level surface with the engine shut off and the parking brake "ON".**

Check item

- Walk around inspection
- Check engine oil level
- Check transmission fluid level
- Check brake fluid level
- Check coolant level
- Clean grill, radiator screen
(When used in a dusty place)
- Check brake and speed control pedal
- Check parking brake
- Check indicators, gauges and meters
- Check lights
- Check seat belt and ROPS
- Check front and rear joint boots
- Check tire inflation pressure
- Check backup beeper (if equipped)
- Refuel
(See "DAILY CHECK" in "PERIODIC SERVICE" section.)
- Care of pictorial safety labels
(See "PICTORIAL SAFETY LABELS" in "SAFE OPERATION" section.)

OPERATING THE ENGINE



CAUTION

To avoid personal injury:

- Read "SAFE OPERATOR" in front of this manual.
- Read the pictorial safety labels located on the vehicle.
- To avoid the danger of exhaust fume poisoning, do not operate the engine in a closed building without proper ventilation.
- Never start engine while standing on ground. Start engine only from operator's seat.
- Make it a rule to set range gear shift lever to the "NEUTRAL" position and to place the hydraulic lift cylinder lever to the "NEUTRAL" position before starting the engine.

IMPORTANT :

- Do not use starting fluid or ether.
- To protect the battery and the starter, make sure that the starter is not continuously turned for more than 10 seconds.

STARTING THE ENGINE

1. Make sure the parking brake is set.

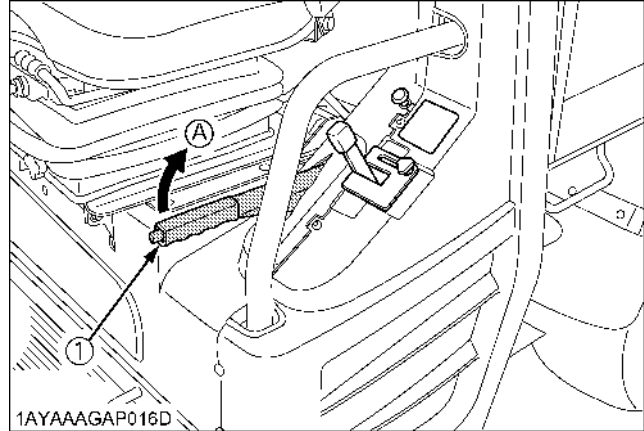

(1) Parking brake lever

(A) Pull to "PARK"

NOTE :

- The parking brake indicator comes on while parking brake is applied and goes off when it is released.
- If the parking brake is released but the lamp stays on, it means that the brake fluid may be low or the brake system may be damaged.
(See "Checking Brake Fluid Level" in "DAILY CHECK" in "PERIODIC SERVICE" section.)

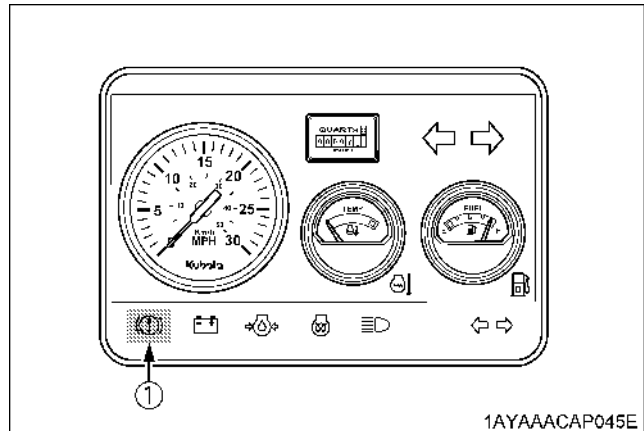

(1) Parking brake indicator

2. Set the range gear shift lever to the "NEUTRAL" position.

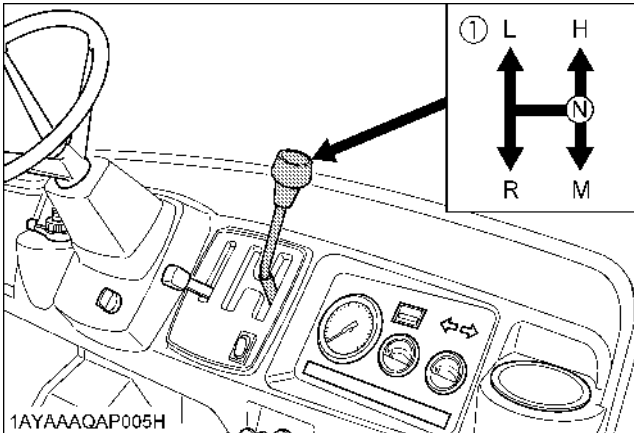

(1) Range gear shift lever
 (L) LOW Range
 (H) HIGH Range
 (R) "REVERSE"
 (M) MEDIUM Range
 (N) "NEUTRAL" POSITION

4. Push the speed control pedal down about 1/2 way.

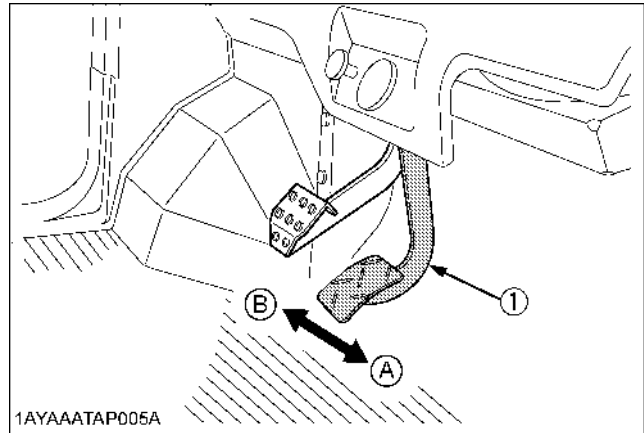

(1) Speed control pedal
 (A) "INCREASE"
 (B) "DECREASE"

3. Lock the hydraulic lift cylinder lever to the "NEUTRAL" position with a restricting plate.

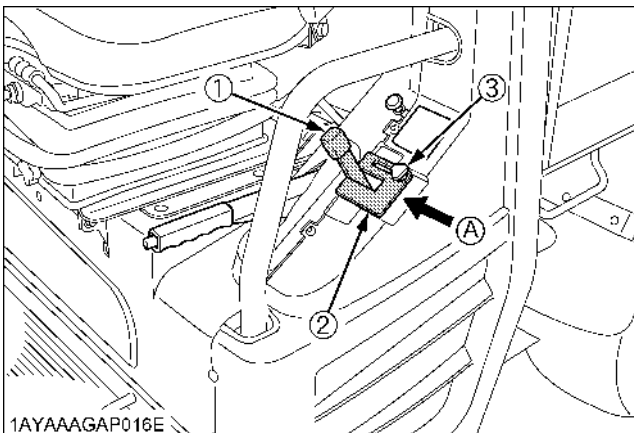

(1) Hydraulic lift cylinder lever
 (2) Restricting plate
 (3) Knob bolt
 (A) "LOCK"

5. Insert the key into the key switch and turn it "ON".

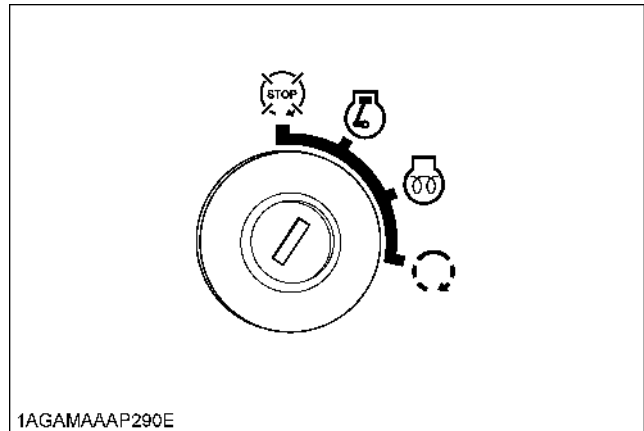

(OFF) "OFF" (Engine-Stop)
 (GLOW) "GLOW" (Preheat)
 (ON) "ON" (Engine-Run)
 (START) "START" (Engine-Start)

◆ **Check Easy Checker(TM) Lamps:**

1. When the key is turned "ON", lamps(2)(3) should come on. If trouble should occur at any location while the engine is running, the warning lamp corresponding to that location comes on.
2. The parking brake warning lamp(1) comes on while parking brake is applied and goes off when it is released.

If the parking brake is released but the lamp stays on, it means that the brake fluid may be low or the brake system may be damaged. (See "Checking Brake Fluid Level" in "DAILY CHECK" in "PERIODIC SERVICE" section.)

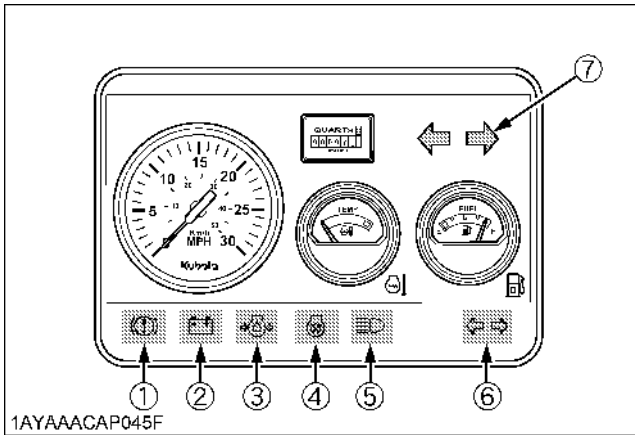

- | | |
|---------------------------------|--------------------------|
| (1) Parking brake / Brake fluid | (5) High-beam |
| (2) Electrical charge | (6) Trailer |
| (3) Engine oil pressure | (7) Hazard / Turn signal |
| (4) Glow plug | |

IMPORTANT :

- Daily checks with the Easy Checker(TM) only, are not sufficient. Never fail to conduct daily checks carefully by referring to "DAILY CHECK" in "PERIODIC SERVICE" section.

6. Turn the key to "PREHEAT" position and hold it for the preheating.

For the appropriate preheating time, refer to the table below:

Temperature	Preheating Time
Over 0 °C	2 to 3 sec.
0 to -5 °C	5 sec.
-5 to -15 °C	10 sec.
Limit of continuous use	30 sec.

NOTE :

- Glow plug indicator(4) comes on while key switch is in the "GLOW" position or "START" position.

7. Turn the key to "START" position and release when the engine starts.

IMPORTANT :

- Because of safety devices, the engine will not start except when the range gear shift lever is placed in the "NEUTRAL" position.

■ **Cold Weather Starting**

When the ambient temperature is below 0 °C and the engine is very cold. If the engine fails to start after 10 seconds, turn off the key for 30 seconds. Then repeat steps 6 and 7. To protect the battery and the starter, make sure that the starter is not continuously turned for more than 30 seconds.

■ **Block Heater**

[if equipped]

A block heater is available as an option from your dealer. It will assist you in starting your vehicle when the ambient temperature is below -20 °C .

8. Check to see that all the lamps on the Easy Checker(TM) are "OFF".

If any lamp stays on, immediately stop the engine and determine the cause.

STOPPING THE ENGINE

1. After slowing the engine to idle, turn the key to "OFF".
2. Remove the key.

WARMING UP



CAUTION

To avoid personal injury:

- Be sure to set the parking brake during warm-up.
- Be sure to set the range shift lever to the "NEUTRAL" position and lock the hydraulic lift cylinder lever to the "NEUTRAL" position with restricting plate during warm-up.

For 5 minutes after engine start-up, allow the engine to warm up without applying any load. This is to allow oil to reach every engine part. If load should be applied to the engine without this warm-up period, trouble such as seizure, breakage or premature wear may develop.

■ Warm-Up Transmission Oil in the Low Temperature Range

Hydraulic oil serves as transmission fluid. In cold weather, the oil may be cold with increased viscosity. This can cause delayed oil circulation or abnormally low hydraulic pressure for some time after engine start-up. This in turn can result in trouble in the hydraulic system.

To prevent the above, observe the following instructions: Warm up the engine at about 50% of rated rpm according to the table below:

Ambient temperature	Warm-up time requirement
Above 0 °C	Approx. 5 minutes
0 to -10 °C	5 to 10 minutes
-10 to -20 °C	10 to 15 minutes
Below -20 °C	More than 15 minutes

IMPORTANT :

- Do not operate the vehicle under full load condition until it is sufficiently warmed up.

JUMP STARTING



CAUTION

To avoid personal injury:

- Battery gases can explode. Keep cigarettes, sparks, and flames away from battery.
- If vehicle battery is frozen, do not jump start engine.
- Do not connect other end of negative jumper cable to negative terminal of vehicle battery.
- The parts such as the muffler may be hot. Be careful not to get burned in connecting jumper cables.

When jump starting engine, follow the instructions below to safely start the engine.

1. Bring helper vehicle with a battery of the same voltage as disabled vehicle within easy cable reach. "THE VEHICLES MUST NOT TOUCH".
2. Engage the parking brake of both vehicles and put the shift lever in neutral. Shut the engine off.
3. Put on safety goggles and rubber gloves.
4. Ensure the vent caps are securely in place. (if equipped)
5. Cover vent holes with damp rags. Do not allow the rag to touch the battery terminals.
6. Attach the red clamp to the positive (red, (+) or pos.) terminal of the dead battery and clamp the other end of the same cable to the positive (red, (+) or pos.) terminal of the helper battery.
7. Clamp the other cable to the negative (black, (-) or neg.) terminal of the helper battery.
8. Clamp the other end to the engine block or frame of the disabled vehicle as far from the dead battery as possible.
9. Start the helper vehicle and let its engine run for a few moments. Start the disabled vehicle.
10. Disconnect the jumper cables in the exact reverse order of attachment. (Steps 8, 7 and 6).
11. Remove and discard the damp rags.

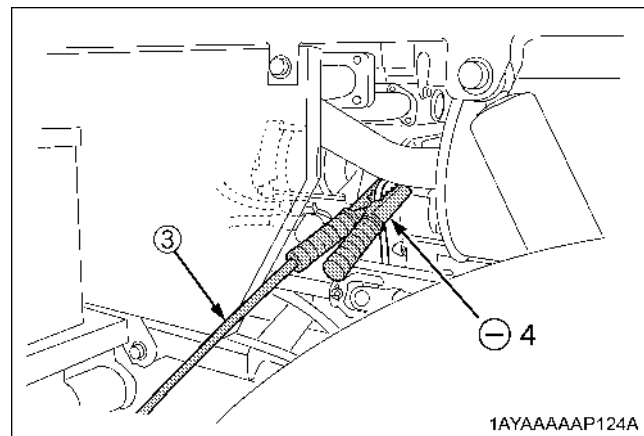
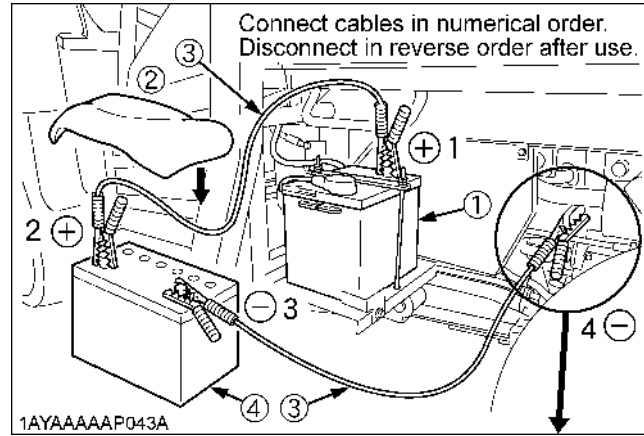

- (1) Dead battery
- (2) Lay a damp rag over the vent caps
- (3) Jumper cables
- (4) Helper battery

IMPORTANT :

- This vehicle has a 12 volt negative (-) ground starting system.
- Use only same voltage for jump starting.
- Use of a higher voltage source could result in severe damage to vehicle's electrical system. Use only matching voltage source when "Jump starting" a low or dead battery.

OPERATING THE VEHICLE

OPERATING NEW VEHICLE

How a new vehicle is handled and maintained determines the life of the vehicle.

A new vehicle just off the factory production line has been, of course, tested, but the various parts are not accustomed to each other, so care should be taken to operate the vehicle for the first 50 hours at a slower speed and avoid excessive work or operation until the various parts become "broken-in." The manner in which the vehicle is handled during the "breaking-in" period greatly affects the life of your vehicle. Therefore, to obtain the maximum performance and the longest life of the vehicle, it is very important to properly break-in your vehicle. In handling a new vehicle, the following precautions should be observed.

■ Do not Operate the Vehicle at Full Speed for the First 50 Hours

- Do not start quickly nor apply the brakes suddenly.
- In winter, operate the vehicle after fully warming up the engine.
- Do not run the engine at speeds faster than necessary.
- On rough roads, slow down to suitable speeds. Do not operate the vehicle at fast speed. The above precautions are not limited only to new vehicles, but to all vehicles. But it should be especially observed in the case of new vehicles.

■ Changing Lubricating Oil for New Vehicles

The lubricating oil is especially important in the case of a new vehicle. The various parts are not "broken-in" and are not accustomed to each other. Small pieces of metal grit may develop during the operation of the vehicle; and this may wear out or damage the parts. Therefore, care should be taken to change the lubricating oil a little earlier than would ordinarily be required. For further details of change interval hours, see "MAINTENANCE" section.

STARTING

1. Adjusting the operator's position

■ Operator's Seat



CAUTION

To avoid personal injury:

- Make adjustments to the seat only while the vehicle is stopped.
- Make sure that the seat is completely secured after each adjustment.

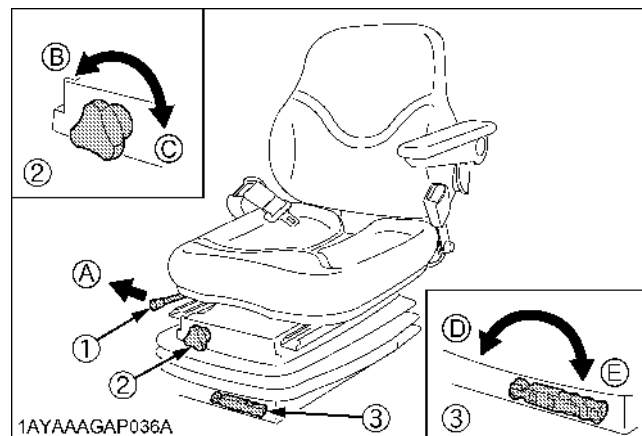

(1) Travel adjust lever

(2) Height adjust knob

(3) Suspension adjust lever

(A) "UNLOCK"

(B) "HIGH"

(C) "LOW"

(D) To decrease tension

(E) To increase tension

◆ Travel adjustment

Unlock the travel adjust lever and slide the seat backward or forward, as required. The seat will lock in position when the lever is released.

◆ Suspension adjustment

Turn the suspension adjust lever to achieve the optimum suspension setting.

◆ Height adjustment

Turn the height adjust knob to desired position while sitting in the seat.

■ Seat Belt



WARNING

To avoid personal injury:

- Seat belts reduce injury. Always wear your seat belts. The lap-style seat belts may not provide adequate protection for small children. Special care is recommended when carrying a child passenger.



CAUTION

To avoid personal injury:

- Always use the seat belts when operating and riding in the vehicle.

Adjust the seat belts for proper fit and connect the buckle. This seat belt is an auto-locking retractable type.

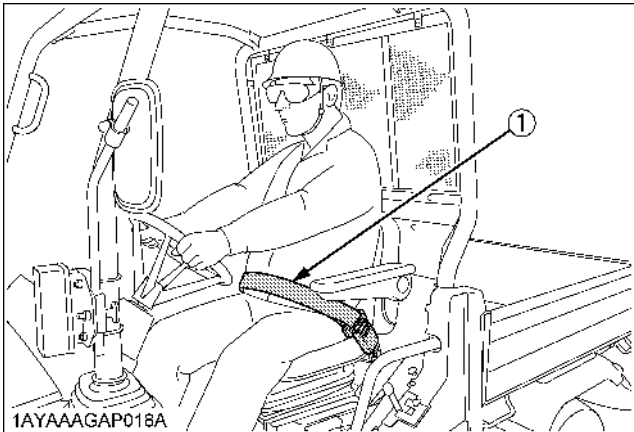

(1) Seat belt

2. Selecting light switch position.

■ Head Light Switch

The head light switch is operative when the key switch is in either the "ON" or "OFF" position.

OFF Head lights OFF.

..... Head lights ON, high beam.

..... Head lights dimmed, low beam.

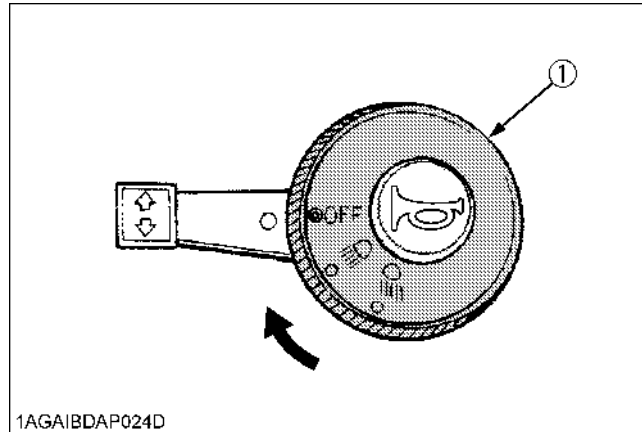

(1) Head light switch

NOTE :

- Turning the head light switch to the "ON" position causes the following lamps to light simultaneously.
 - (1) Tail and number plate lights (lamps at the rear portions of the vehicle)
 - (2) Sidemarker light
 - (3) Lamp built in the coolant temperature gauge
 - (4) Lamp built in the fuel gauge
 - (5) Lamp built in the speedometer
- The head light switch is operative when the key switch is in either the "ON" or "OFF" position. Be careful that leaving the switch "ON" causes the battery to run out.

■ Hazard Light Switch

Press the top half of the hazard light switch, the hazard light flash along with the indicator on the instrument panel. Press the bottom half of the hazard light switch to turn off the hazard light.

NOTE :

- The hazard light switch is operative when the key switch is in either the "ON" or "OFF" position. Be careful that leaving the switch "ON" causes the battery to run out.

■ Turn Signal Light Switch

To indicate a right turn, turn the turn signal light switch clockwise.

To indicate a left turn, turn the turn signal light switch counter-clockwise.

The corresponding right and left turn signal lights and indicator on the instrument panel will flash.

NOTE :

- The turn signal light switch is only operative when the key switch is in the "ON" position.
- If the hazard light switch is pressed to the "ON" position while the turn signal is activated, all the lamps will flash.
- Be sure to return switch to center position after turning.

◆ Trailer Indicator

When you use the turn signal light switch with the trailer power connector connected, the indicator in the instrument panel starts flashing.

NOTE :

- If the indicators in the instrument panel start flashing fast, it means the front or rear turn signal light bulb may be broken. Check the bulbs.

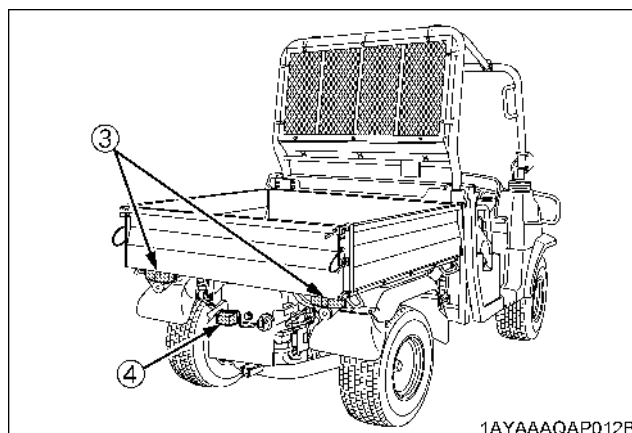
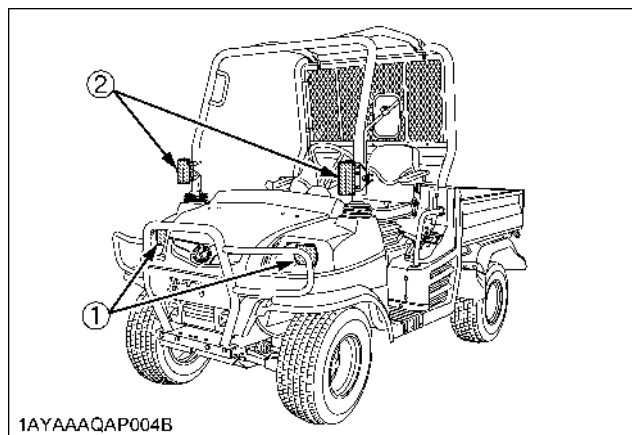

- (1) Head light
- (2) Hazard / Turn signal light
- (3) Tail lamp (Combination lamp)
- (4) Number plate lamp

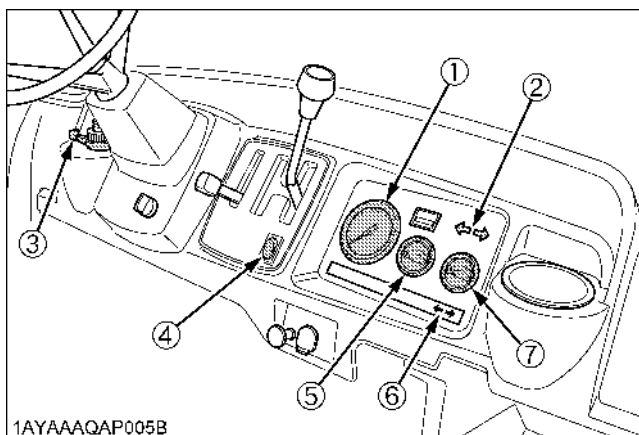

- (1) Speedometer
- (2) Hazard / Turn signal indicator
- (3) Turn signal light switch
- (4) Hazard light switch
- (5) Coolant temperature gauge
- (6) Trailer indicator
- (7) Fuel gauge

■ Horn Button

The horn switch is operative when the key switch is in either the "ON" or "OFF" position.

The horn will sound when the horn button is pressed.

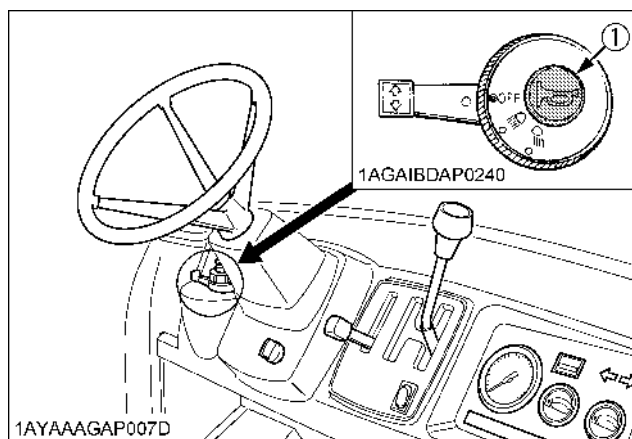

- (1) Horn button

3. Checking the brake pedal.

■ Brake Pedal

CAUTION

To avoid personal injury:

- If the operator suddenly brakes, an accident may occur due to loss of control or the shifting forward of heavy loads.
- When driving on icy, wet or loose surface, make sure the vehicle is correctly ballasted to avoid skidding and loss of steering control. Operate at reduced speed.

The brake pedal is the left pedal on the foot board. Depress the pedal to slow or stop the vehicle.

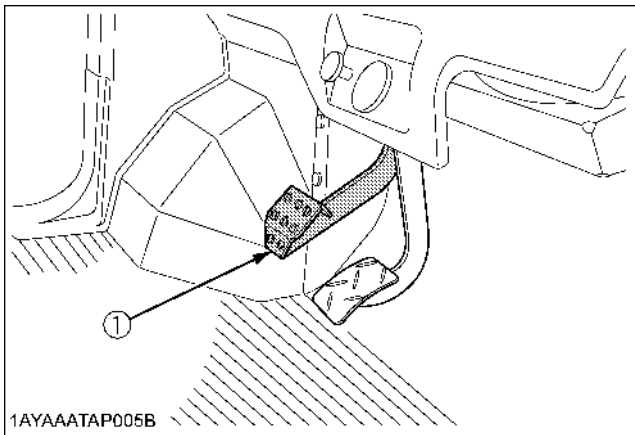

(1) Brake pedal

4. Selecting the travel speed.

■ Range Gear Shift Lever

CAUTION

To avoid personal injury:

- Avoid changing range gear shift lever when ascending or descending a slope.
- Before ascending or descending a slope, shift to the "L" range to control the vehicle speed.
- If you shift gears while ascending or descending a slope, be prepared to use the brake to maintain control.
- Operate in reverse at slow speeds to maintain control.

1. The range gear shift lever can only be shifted when vehicle is completely stopped and the speed control pedal is in the "NEUTRAL" position.
2. To avoid transmission and shift linkage damage, completely stop the vehicle using the brake pedal before shifting gears.
3. Select proper gear and engine speed depending on the type of job.
4. Before dismounting vehicle, shift the range gear shift lever to the "NEUTRAL" position and set parking brake.

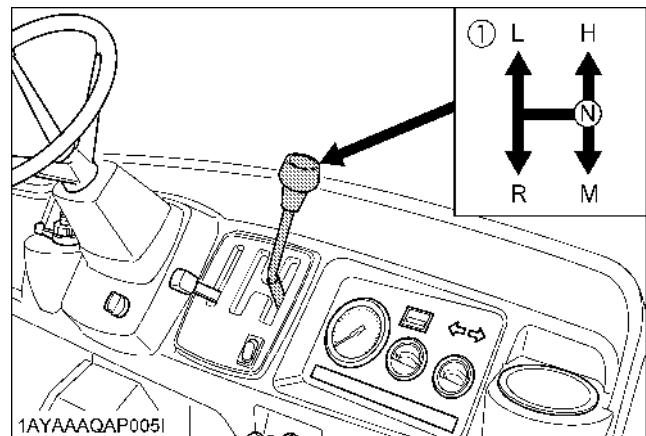

(1) Range gear shift lever
 (L) LOW Range
 (H) HIGH Range
 (R) "REVERSE"
 (M) MEDIUM Range
 (N) "NEUTRAL" POSITION

NOTE :

- Do not force the range gear shift lever. If it is difficult to shift the lever into "L", "M", or "H" on slopes be sure to set the parking brake before starting the procedure.
 - (1) Slightly depress the speed control pedal to rotate the gears inside of transmission.
 - (2) Release the speed control pedal to the "NEUTRAL" position.
- An accident may occur with erratic shifting operation.
- Improper range gear shift lever position will cause the vehicle to momentarily coast on slopes.

■ 4WD Lever



CAUTION

To avoid personal injury:

- Do not engage the front wheel drive when traveling at road speed.
- When driving on icy, wet or loose surfaces, make sure the vehicle is correctly ballasted to avoid skidding and loss of steering control. Operate at reduced speed and engage front wheel drive.
- An accident may occur if the vehicle is suddenly braked, such as by heavy towed loads shifting forward causing loss of control.
- The braking characteristics are different between two and four wheel drive. Be aware of the difference and use carefully.

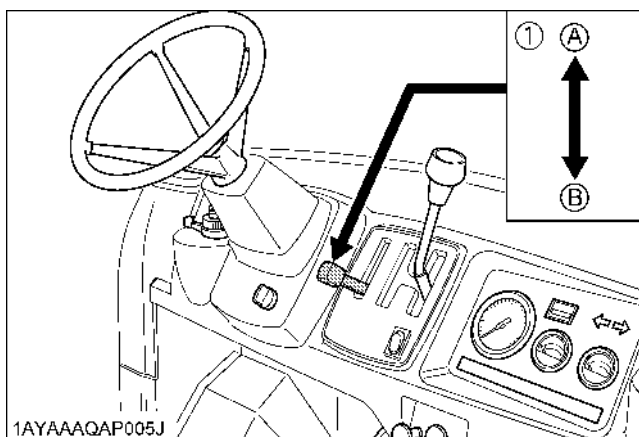

(1) 4WD lever

(A) "4WD"

(B) "2WD"

■ VHT Pressure Release Knob

If the gear shift lever will not disengage, pull and release the VHT pressure release knob with the brake pedal depressed.

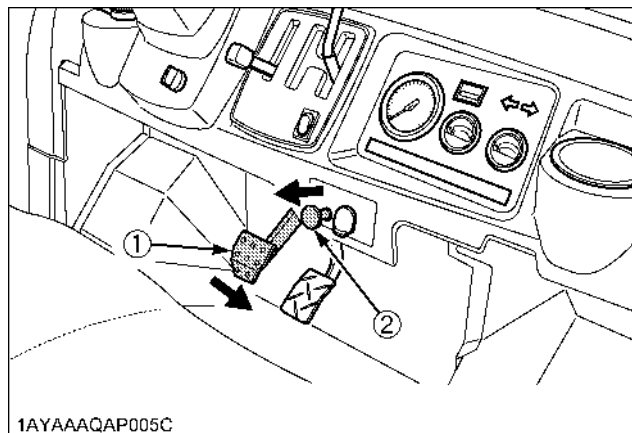

1AYAAAQAP005C

(1) Brake pedal

(2) VHT pressure release knob

IMPORTANT :

- Use the lever to engage the front wheels with the vehicle stopped. Shift the lever to "4WD" to engage the front wheel drive.
- Tires will wear quickly if front wheel drive is engaged on paved roads.
- If the 4WD lever is difficult to shift to "2WD", stop the vehicle, turn the steering wheel in both directions and then move the lever.

◆ Front wheel drive is effective for the following jobs:

1. When greater pulling force is needed, such as working in a wet field, when pulling a trailer, or when working with a front-end blade.
2. When working in sandy soil.

5. Unlock the parking brake and start slowly.

■ Parking Brake Lever

To release the parking brake, depress the brake pedal, push release button and push down parking brake lever. Make sure that indicator in the Easy Checker(TM) goes off.

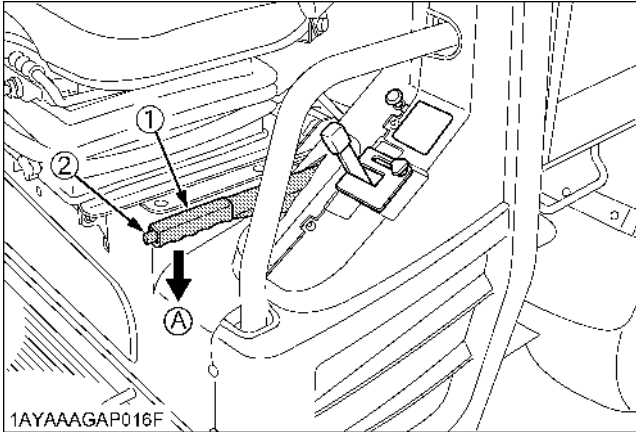

(1) Parking brake lever (A) "RELEASE"
(2) Release button

■ Speed Control Pedal

Use the speed control pedal when traveling. Push down on it for higher speed.

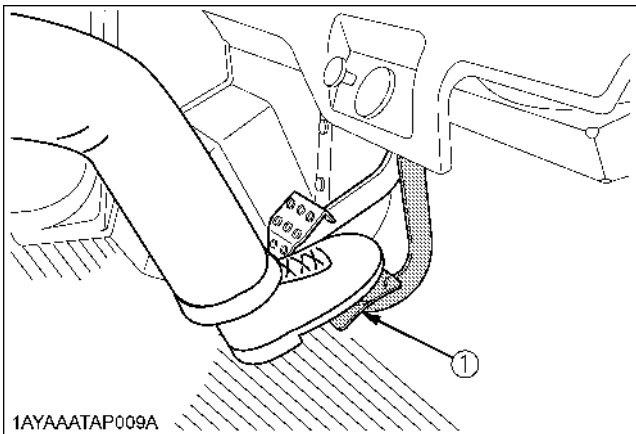

(1) Speed control pedal

STOPPING

■ Stopping

1. Release the speed control pedal.
2. Step on the brake pedal.
3. After the vehicle has stopped, put the range gear shift lever in neutral, and set the parking brake.

CHECK DURING DRIVING

■ Immediately Stop the Engine if:

- The engine suddenly slows down or accelerates,
 - Unusual noises are suddenly heard,
 - Exhaust fumes suddenly become very dark,
- While driving, check the following items to see that all the parts are functioning normally.

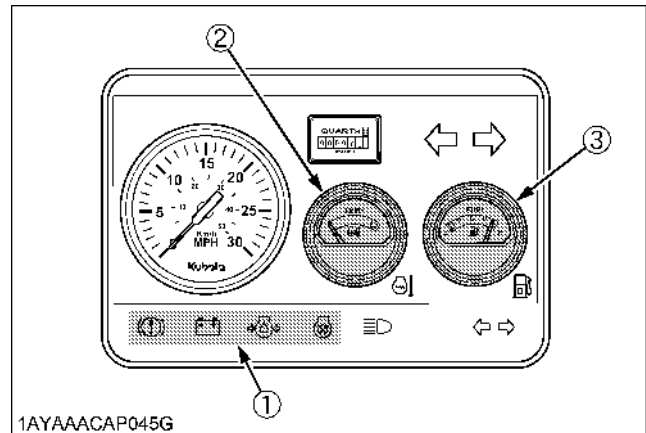

(1) Easy Checker(TM)
(2) Coolant temperature gauge
(3) Fuel gauge

■ Easy Checker(TM)

If the warning lamps in the Easy Checker(TM) come on during operation, immediately stop the engine, and find the cause as shown below.

Never operate the vehicle with an Easy Checker(TM) lamp on.

⚠ Engine oil pressure

If the oil pressure in the engine goes below the prescribed level, the warning lamp in the Easy Checker(TM) will come on.

If this should happen during operation, and it does not go off when the engine is accelerated, check level of engine oil.

(See "Checking Engine Oil Level" in "DAILY CHECK" in "PERIODIC SERVICE" section.)

⚡ Electrical charge

If the alternator is not charging the battery, the Easy Checker(TM) will come on.

If this should happen during operation, check the electrical charging system or consult your local KUBOTA Dealer.

(ⓘ) Alarm against low brake fluid level or parking brake operation.

The warning lamp in the Easy Checker(TM) comes on if the parking brake is applied.

If the lamp is on during operation, release the parking brake lever immediately.

If the brake fluid goes below the prescribed level, the warning lamp in the Easy Checker(TM) will come on. If this should happen during operation, check to see that there is no oil leak in the brake system, and then add oil.

(See "Checking Brake Fluid Level" in "DAILY CHECK" in "PERIODIC SERVICE" section.)

■ Fuel Gauge

Park the vehicle on a flat place.

When the key switch is "ON", the fuel gauge indicates the fuel level.

Be careful not to empty the fuel tank. Otherwise air may enter the fuel system.

Should this happen, the system should be bled. (See "Bleeding Fuel System" in "SERVICE AS REQUIRED" in "PERIODIC SERVICE" section.)

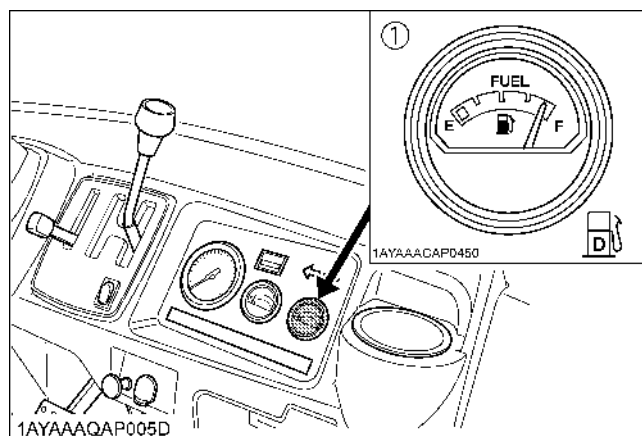

(1) Fuel gauge

■ Coolant Temperature Gauge



CAUTION

To avoid personal injury:

- Do not remove radiator cap until coolant temperature is well below its boiling point. Then loosen cap slightly to the stop to relieve any pressure before removing cap completely.

1. With the key switch "ON" the temperature gauge indicates the temperature of the coolant. White Zone for "cold" and Red zone for "hot".
2. If the indicator reaches the Red zone, engine coolant is overheated. Check the vehicle by referring to "TROUBLESHOOTING" section.

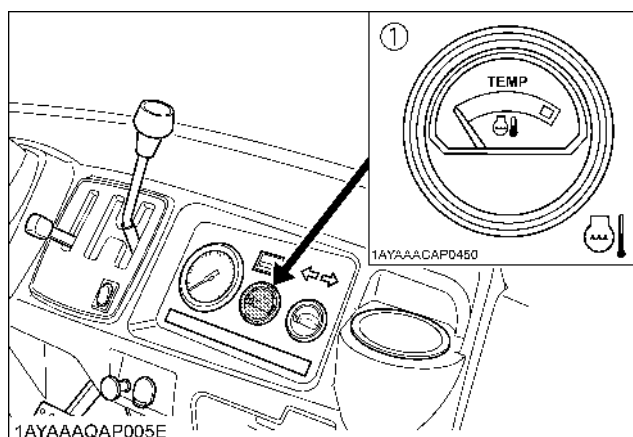

(1) Coolant temperature gauge

■ Hourmeter

The hourmeter indicates in five digits the hours the vehicle has been used; the last digit indicates 1/10 of an hour.

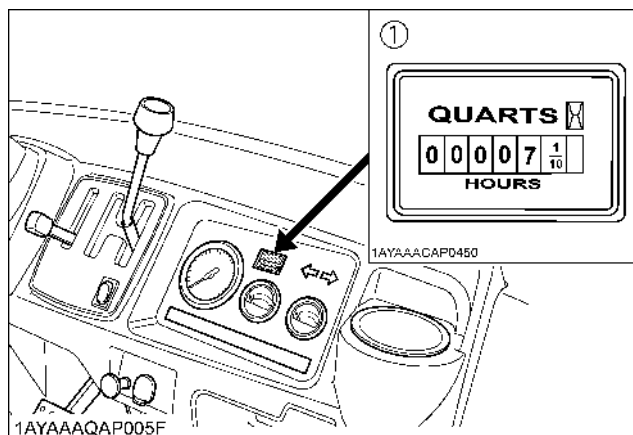

(1) Hourmeter

Speedometer

The speedometer indicates the traveling speed.

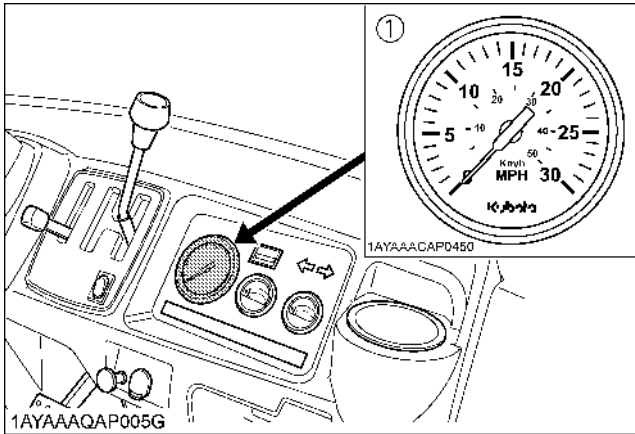

(1) Speedometer

NOTE :

- The speed shown on the speedometer is based on 25 inch diameter tires. If 23 inch diameter tires are mounted, the actual speed will be less than shown on the speedometer.

PARKING

Parking Brake Lever



CAUTION

To avoid personal injury:

BEFORE DISMOUNTING VEHICLE

- **ALWAYS SET PARKING BRAKE AND LOWER ALL IMPLEMENTS TO THE GROUND.**
Leaving transmission in gear with the engine stopped will not prevent from rolling.
- **STOP THE ENGINE AND REMOVE THE KEY.**

1. Stop the vehicle on a level surface.
2. To set the parking brake, depress the brake pedal and pull the lever to park.
3. To release the parking brake, push release button and push down the parking brake lever. When the parking brake is released, the parking brake warning lamp in the Easy Checker(TM) goes off.

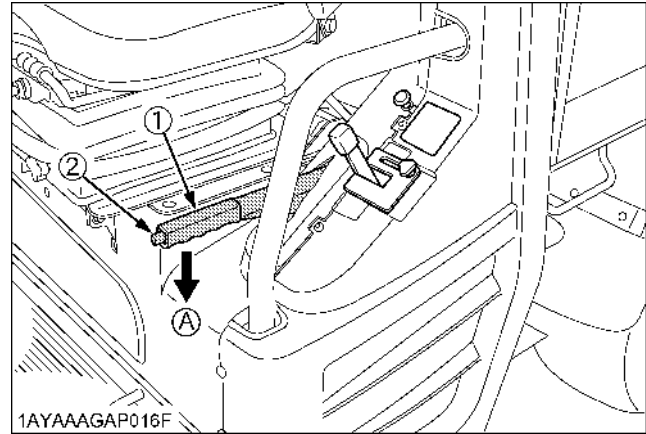

(1) Parking brake lever

(A) "RELEASE"

(2) Release button

IMPORTANT :

- If the vehicle is operated with the parking brake applied, the parking brake will be damaged.

ACCESSORY

12V Electric Outlet

The 12 volt receptacle is located on the front-panel. An auxiliary light or other devices may be connected to this connector.

◆ This outlet is activated when the key switch is in either the "ON" or "OFF" position.

When the plug is not used, pull it out. Be careful that leaving the plug inserted causes the battery to run out.

◆ Do not connect a light or other device that draws more than 120 watts to this connector, or the battery may discharge very rapidly or the outlet may fail.

IMPORTANT :

- Do not use as a cigarette lighter.
- Do not use when wet.

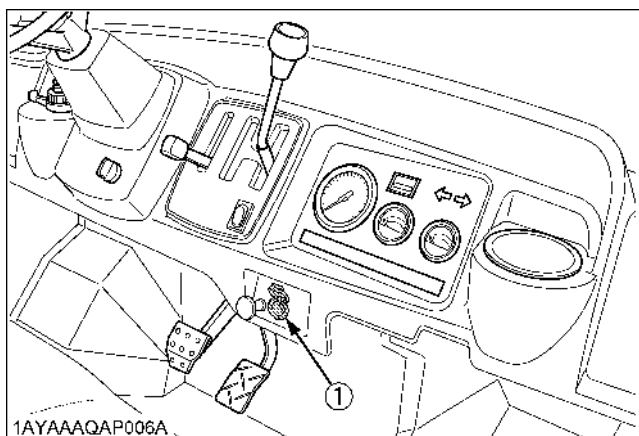

(1) 12V electric outlet

Rotating Beacon Light Outlet

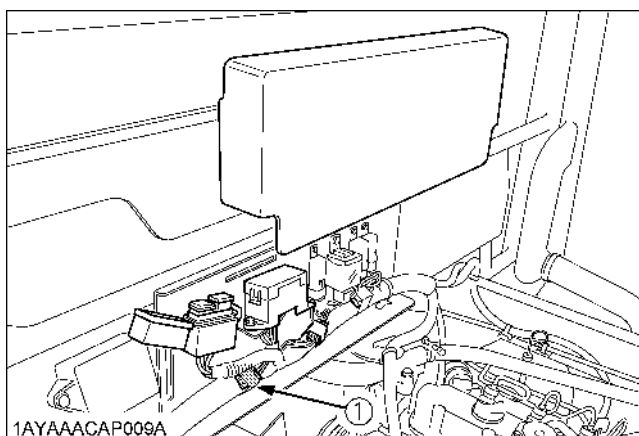

(1) Connector

Trailer Electrical Outlet

A trailer electrical outlet is supplied for use with trailer or implement.

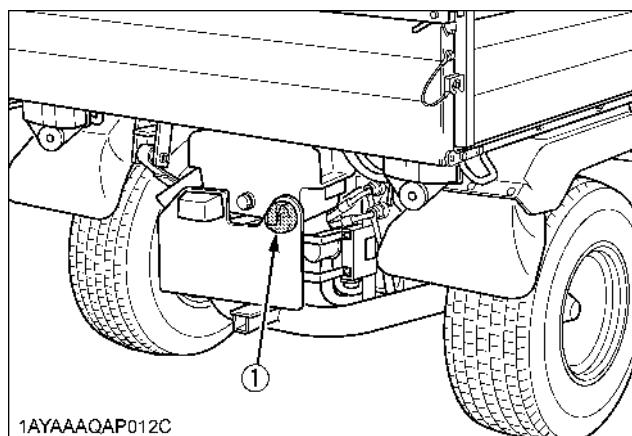

(1) Trailer electrical outlet

Function of each terminals in trailer electrical outlet

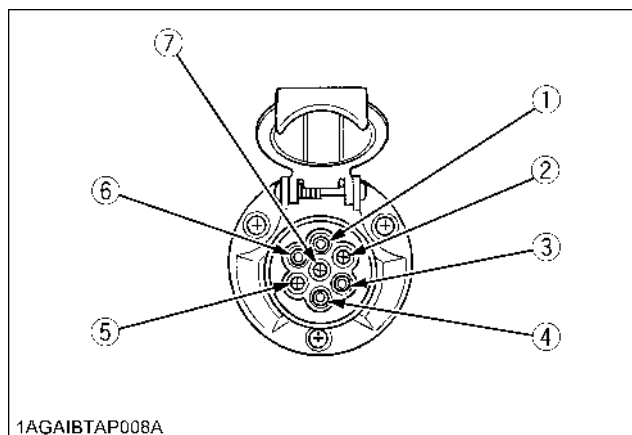

Terminal	Function
(1)	Turn signal light (LH)
(2)	---
(3)	Ground
(4)	Turn signal light (RH)
(5)	Tail light Sidemarker light
(6)	Brake stop light
(7)	Number plate light

Utility Box

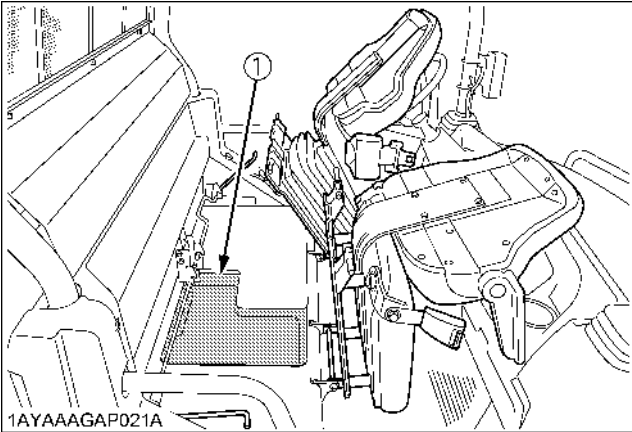

(1) Utility Box

OPERATING TECHNIQUES

Differential Lock

WARNING

To avoid personal injury due to loss of steering control:

- Do not operate the vehicle at high speed with differential lock engaged.
- Do not attempt to turn with the differential lock engaged.
- Be sure to release the differential lock before making a turn in field conditions.

If one of the rear wheels should slip, step on the differential lock pedal. Both wheels will then turn together, reducing slippage.

Differential lock is maintained while the pedal is depressed or may be held by using differential lock holder.

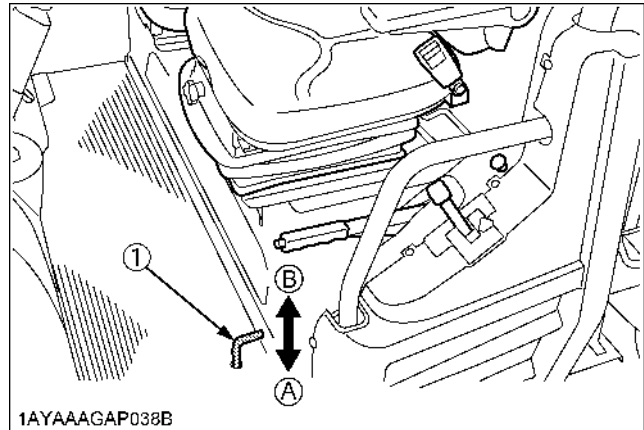

(1) Differential lock pedal

(A) Press to "ENGAGE"

(B) Release to "DISENGAGE"

◆ Handling the retaining device for differential lock

1. Pull the differential lock holder while the differential lock pedal is depressed.
2. The differential lock is then maintained even if your foot leaves the pedal.
3. The lock is released when the pedal is depressed again.

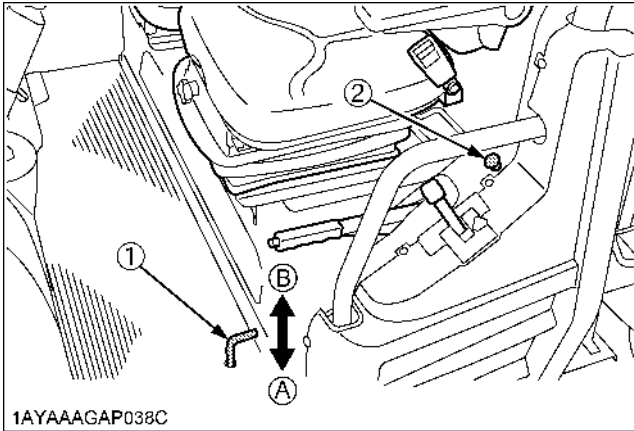

1AYAAAGAP038C

- (1) Differential lock pedal (A) Press to "ENGAGE"
 (2) Differential lock holder (B) Depress to release again "DISENGAGE"

IMPORTANT :

- When using the differential lock, always slow the engine down.
- To prevent damage to power train, do not engage differential lock when one wheel is spinning and the other is completely stopped.
- If the differential lock cannot be released, stop the vehicle, turn the steering wheel alternately.

■ Directions for Use of Power Steering

1. Power steering is activated only while the engine is running. While the engine is stopped, the vehicle functions in the same manner as vehicle without power steering.
2. When the steering wheel is turned all the way to the stop, the relief valve is activated. Do not hold the steering wheel in this position for a long period of time.
3. Avoid turning the steering wheel while the vehicle is stopped, or tires may wear out sooner.
4. The power steering mechanism makes the steering easier. Be careful when driving at high speeds.

■ Unfamiliar Terrain



CAUTION

To avoid personal injury:

- Be sure to check for hidden obstacles or hazards before driving in a new area.
- Keep your speed down until you know the area well.
- Use existing trails and stay away from hazardous areas such as steep, rocky slopes or swamps.
- Be cautious when visibility is limited, as you may not be able to see obstacles in your path.

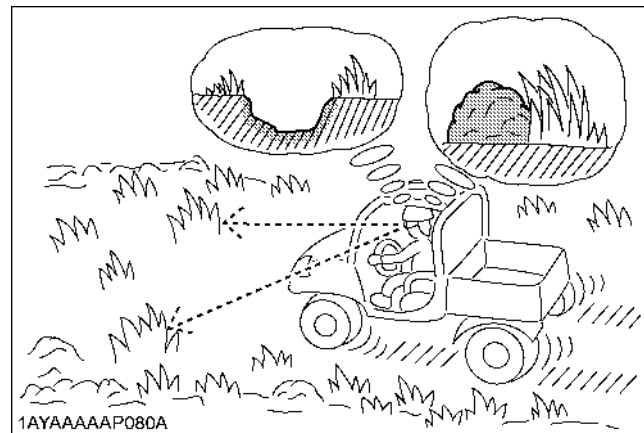

1AYAAAAAP080A

■ Driving in Reverse



CAUTION

To avoid personal injury:

- Turn around, look down and behind you before backing up to be sure there are no obstacles or people in your way.
- Depress speed control pedal gradually and back up cautiously.
- To stop while driving in reverse take your foot off the speed control pedal and gradually apply the brake.
- Do not suddenly engage the brake.

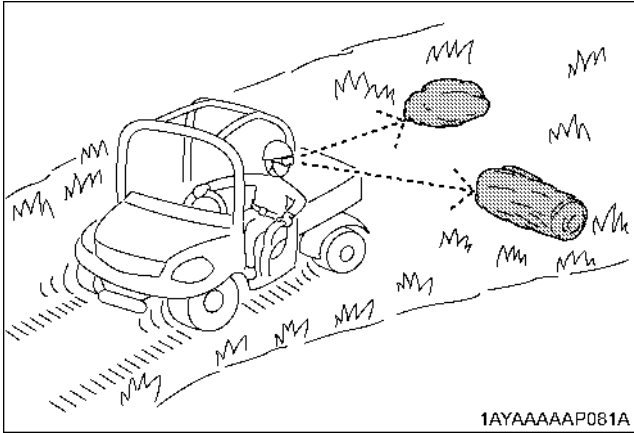

1AYAAAAAP081A

■ Driving in "4WD"



CAUTION

To avoid personal injury:

- Do not drive in "4WD" on paved surfaces.

The maximum traction, shift the range gear shift lever into low range and use "4WD" on steep slopes or when stuck in the mud, with differential locked if necessary.



1AYAAAAAP083A

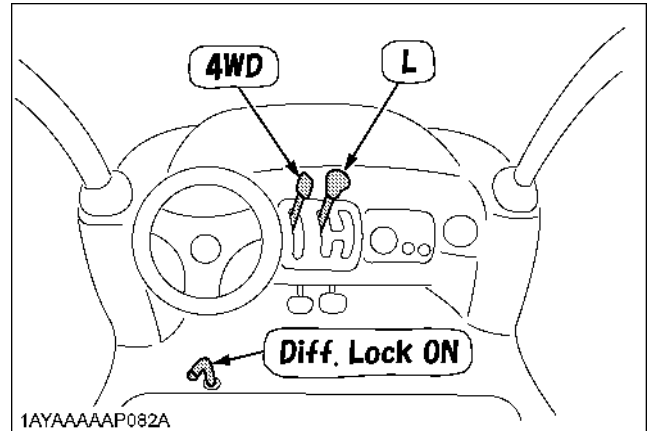

1AYAAAAAP082A

Turning the Vehicle



WARNING

To avoid personal injury:

- Reduce vehicle speed before entering the turn and maintain an even speed through the turn.
- Do not make sharp turns in order to avoid loss of control or tipping.

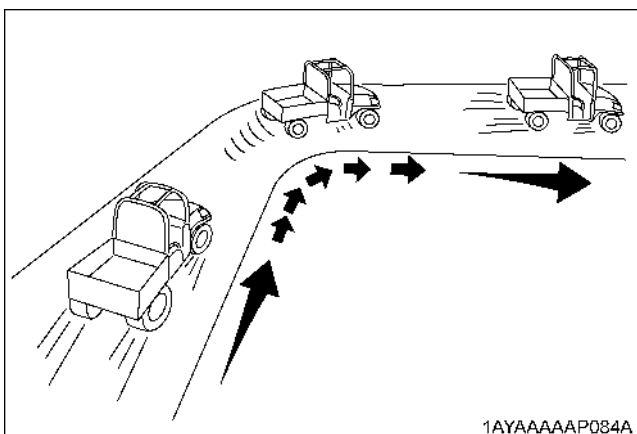

1AYAAAAAP084A

Hills



WARNING

To avoid personal injury:

- Do not turn sideways on a hill, or the vehicle may roll over.
- Always go straight up hill or down hill.
- Slow down until you can get a clean view of the other side at the crest of a hill.
- If the engine stalls on a steep slope, roll slowly straight down, using the brake.
- Stop and look for obstacles before descending a hill.

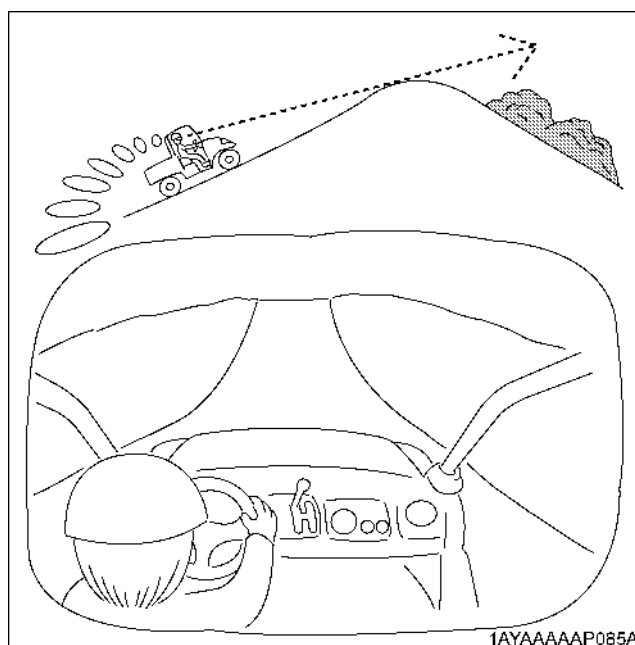

1AYAAAAAP085A

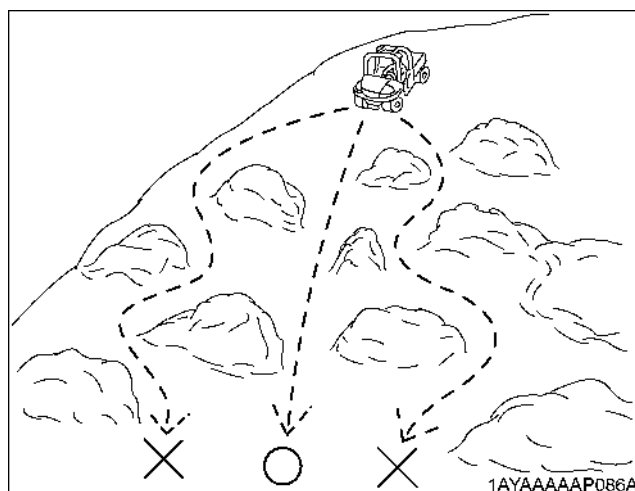

1AYAAAAAP086A

■ Traversing Hillsides



WARNING

To avoid personal injury:

- Reduce vehicles speed to prevent tipping or loss of control.
- Do not traverse hillsides that are slippery or covered with rocks or obstacles which may cause you to tip over.

■ Sliding and Skidding



WARNING

To avoid personal injury:

- Drive slowly and carefully when you are unsure or unprepared for the surface.
- Do not apply heavy braking force or accelerate when skidding to prevent loss of control.
- Use 4WD and maintain low speeds on areas covered with clay, mud, ice or snow to prevent uncontrolled skidding.

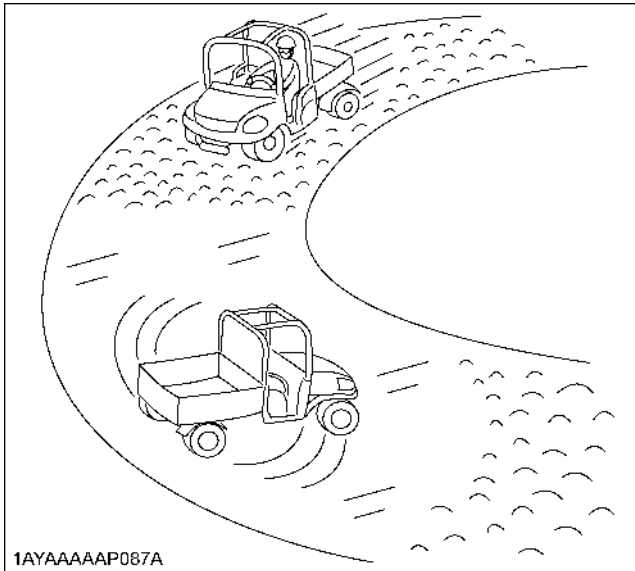

1AYAAAAAP087A

■ Driving through Water



WARNING

To avoid personal injury:

- Do not drive through water whenever it is possible.
- Drive slowly across shallow water and choose a location to enter and exit the water where the banks are not too steep or slippery.
- Check before entering for rocks, holes or other obstacles that may cause overturn, stuck or submerged.
- Never operate the vehicle in the fast flowing water or in water deeper than the bottom edge of the axle caps.



1AYAAAAAP088A

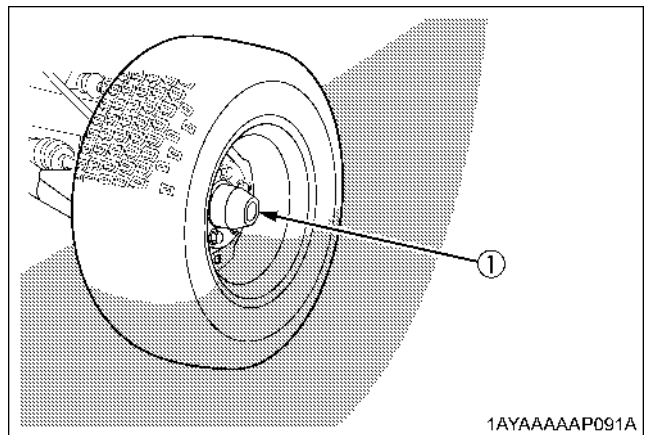

1AYAAAAAP091A

(1) Axle cap

CARGO BED

CARGO BED

General Caution











WARNING

To avoid personal injury:

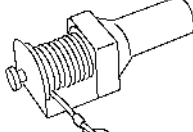
- Never carry passengers in the cargo bed. They can be tossed about or even thrown off causing serious injury or death.
- Driving with the cargo bed tilted may be hazardous.
Always lower the bed and lock the hydraulic lift cylinder lever before driving.
- Be careful not to put any part of your body, such as hands or arms, between the bed and vehicle.
- Drive slowly when it is loaded.

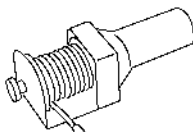
Max. Cargo Load

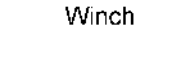
	Operator	Passenger	Implement	Max. Cargo Load
ROPS type 	 95 kg	---	W: weight 	500 kg - W
	 95 kg	 95 kg	Blade 	500 kg - W
CAB type  120 kg <small>1AYAAAAAP125E</small>	 95 kg	---		475 kg - W
	 95 kg	 95 kg	Winch 	380 kg - W

IMPORTANT :

- Maximum Cargo Load (MCL) capacity is 500 kg.
- Never carry loads exceeding the Permissible Cargo Load (PCL).

NOTE :

- Max. Cargo load should not exceed "500 kg" or "PCL".
 PCL = PC - (operator + passenger + opt. + acc. + cabin) weight
 (PCL: Permissible Cargo Load / PC: Payload Capacity / opt.: option / acc.: accessory)

[Payload capacity]

Model		Worksite	Recreational
Payload capacity	kg	695	690

■ Cargo Bed Tailgate



CAUTION

To avoid personal injury:

- Do not apply a load to the tailgate while the tailgate is open, or the wire loop may break.
- Do not place fingers or hands between the tailgate and the arm (latch) when closing, or fingers or hands may be pinched.

For loading and unloading, the tailgate of the cargo bed can be opened.

The tailgate is held level to the cargo bed floor with wire loops.

Do not move the vehicle with the tailgate fully lowered.

In a fully lowered position, the tailgate may obstruct the vehicle tail lamps and damage them by swinging motion.

1. Raise the arms (latch) at each end of the tailgate and open the tailgate.
2. Close the tailgate by lifting it and pushing it firmly closed. Push the arms (latch) down to make sure the latches stay securely closed.

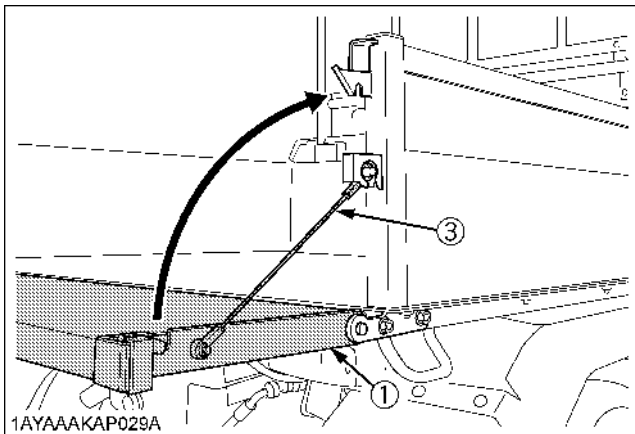
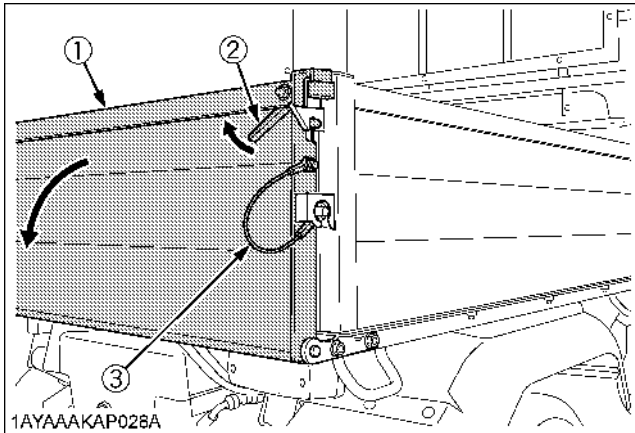

(1) Tailgate

(2) Arm (latch)

(3) Wire loop

IMPORTANT :

- TO AVOID TAILGATE DAMAGE:
Remove the rear trailer hitch when wire loop is removed and cargo bed is raised.

■ Raising and Lowering the Cargo Bed



CAUTION

To avoid personal injury;

- Make sure the vehicle is on a firm, level surface and the parking brake is applied before raising the cargo bed.
- If the vehicle is facing uphill with cargo bed raised, the weight of the cargo bed may cause the vehicle tip.
- When servicing under raised bed with lift cylinder, make sure safety support is properly mounted.

◆ To raise the cargo bed

1. Start engine.
2. Release the restricting plate.
3. Pull up the hydraulic lift cylinder lever to raise the cargo bed.
4. Return the hydraulic lift cylinder lever to the "NEUTRAL" position immediately after raising the cargo bed.

◆ To lower the cargo bed

1. Shift the hydraulic lift cylinder lever to the "DOWN" position and then lower the cargo bed.
2. After making sure that the bed has been lowered to the lowest position, return the lever to the "NEUTRAL" position and then lock the lever with the restricting plate.

◆ Using the "FLOAT" position

1. If the cargo bed cannot be raised or lowered due to trouble with the engine or hydraulic system, shift the lever to the "FLOAT" position. The cargo bed can be raised or lowered manually.

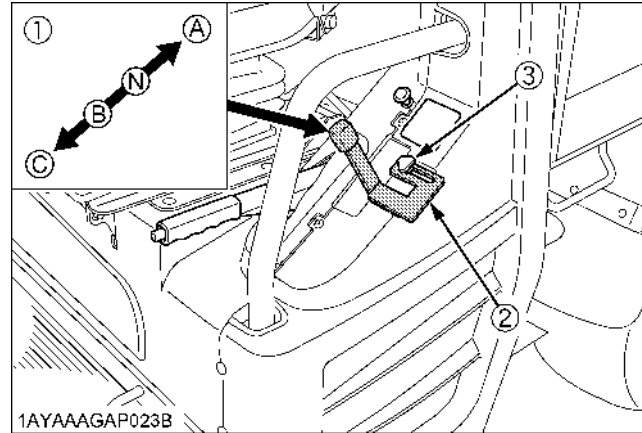

- (1) Hydraulic lift cylinder lever
 (2) Restricting plate
 (3) Knob bolt

- (A) "UP"
 (N) "NEUTRAL"
 (B) "DOWN"
 (C) "FLOAT with Detent"

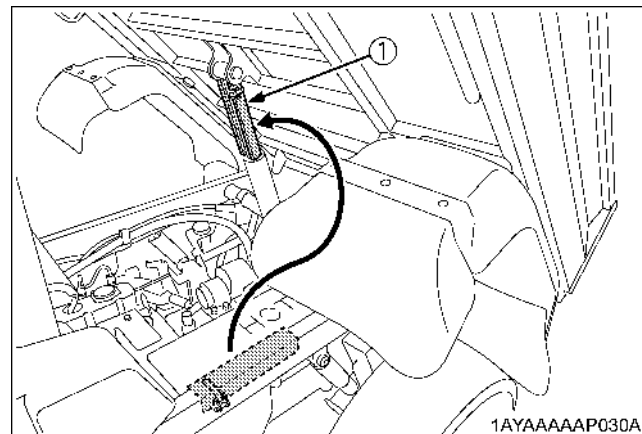

- (1) Safety support

TIRES AND WHEELS

TIRES



WARNING

To avoid personal injury:

- Do not attempt to mount a tire on a rim. This should be done by a qualified person with the proper equipment.
- Always maintain the correct tire pressure. Do not inflate tires above the recommended pressure shown in the operator's manual.

IMPORTANT :

- Do not use tires other than those approved by KUBOTA.

■ Inflation Pressure

Though the tire pressure is factory-set to the prescribed level, it naturally drops slowly in the course of time. Thus, check it everyday and inflate as necessary.

Tire sizes	Inflation Pressure
25 x 10 - 12 HDWS, Front & Rear	140 kPa (1.4 kgf/cm ²)
25 x 10 - 12 ATV, Front	
25 x 11 - 12 ATV, Rear	

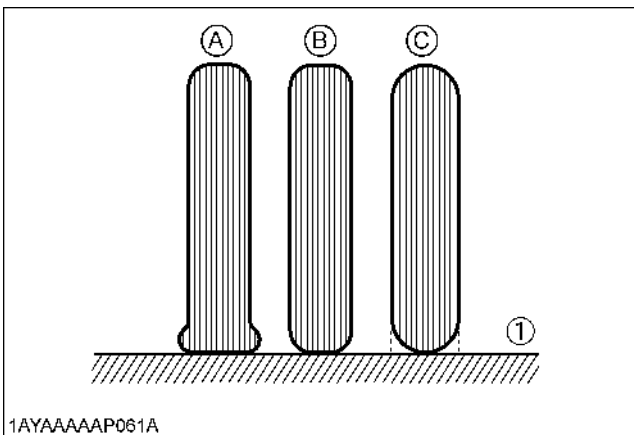

(1) Ground

- (A) "INSUFFICIENT"
- (B) "NORMAL"
- (C) "EXCESSIVE"

■ Tire Type and Use

◆ Heavy duty work site tire

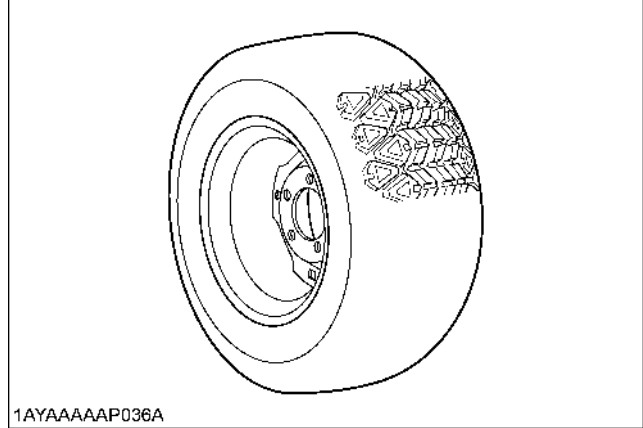

◆ All terrain vehicle tire

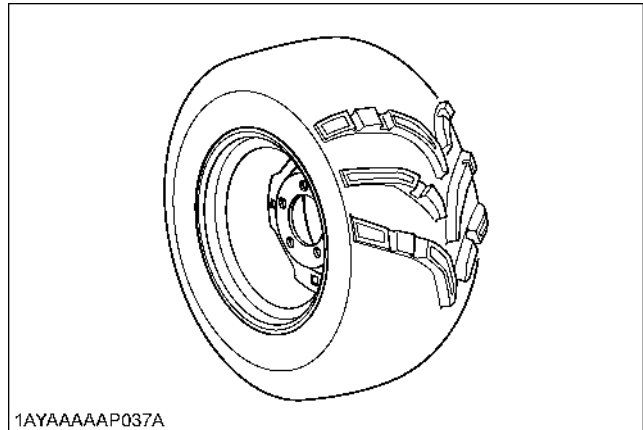

WHEELS



CAUTION

To avoid personal injury:

- Support vehicle securely on stands before removing a wheel.
- Never operate vehicle with loose wheel bolts.

IMPORTANT :

- When re-fitting a wheel, tighten the bolts to the following torques then recheck after driving the vehicle 200 m and thereafter according to service interval.

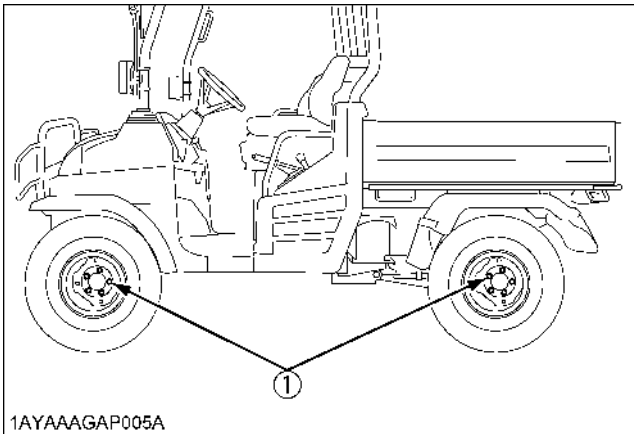

(1) Torque wheel bolts to 75 to 90 N-m (7.6 to 9.2 kgf-m)

TOWING AND TRANSPORTING

TOWING AND TRANSPORTING

■ Rear Trailer Hitch



WARNING

To avoid personal injury:

- Always tow a load slowly enough to maintain control and avoid tipping.
- To provide adequate braking ability and traction, do not tow a load unless vehicle cargo bed is loaded or attachment is installed.
- Attach a trailer to the trailer hitch only.

The rear trailer hitch load is referred to "VEHICLE LIMITATIONS" section. When towing other equipment, use a safety chain.

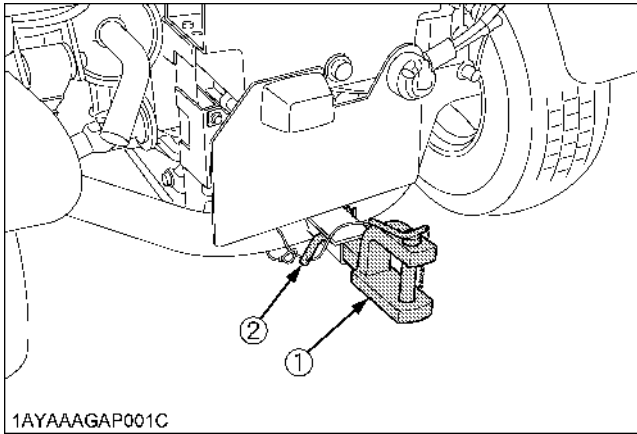

1AYAAAGAP001C

- (1) Rear trailer hitch
(2) Hitch pin

■ Front Coupling



WARNING

To avoid personal injury:

- Do not tow this vehicle unless all the functions of the vehicle are properly working, since the malfunction of steering operation or braking may cause an accident.

Use the front coupling for greater maneuverability in confined areas such as a barn.

The front coupling load is referred to "VEHICLE LIMITATIONS" section.

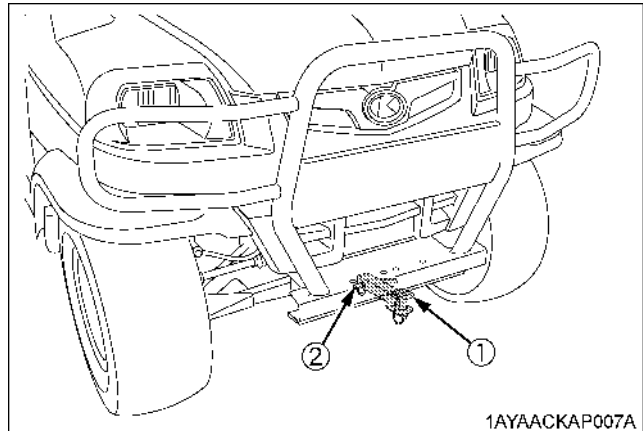

1AYAACKAP007A

- (1) Front coupling
(2) Coupling pin

Winch Mount Bracket [if equipped]

Mounting the optional winch always requires reading the instruction manual attached to the winch thoroughly before using it.

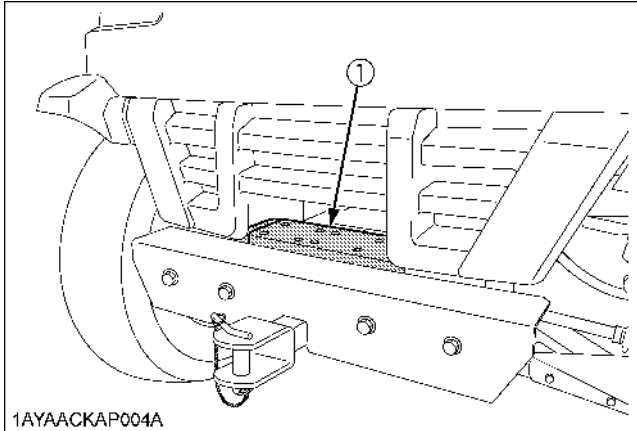

(1) Winch mount bracket

Transporting Vehicle

Pay attention to the points below when transporting the vehicle.

1. Use a suitable truck or trailer.
2. Apply the parking brake and place chocks against the front and rear tires.
3. Secure the portions of the vehicle, which are shown in the figure below, by using strong straps or chains.

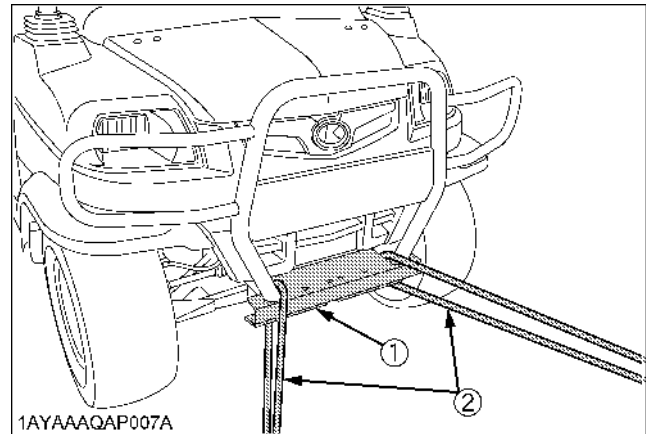

(1) Front bumper
(2) Heavy-duty strap

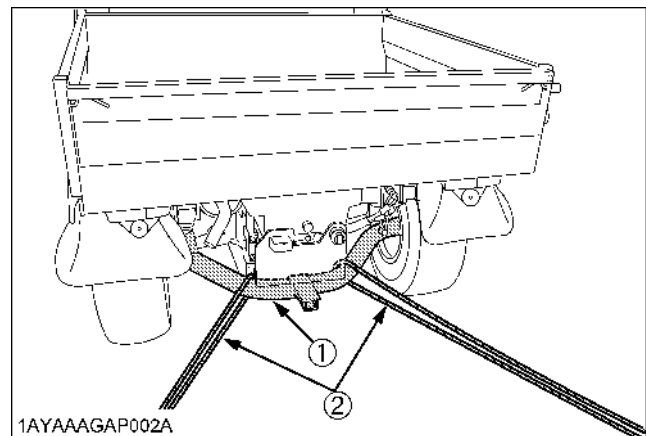

(1) Pipe frame
(2) Heavy-duty strap

MAINTENANCE



CAUTION

To avoid personal injury and vehicle damage:

- Be sure you have sufficient knowledge, experience, the proper replacement parts and tools before you attempt any vehicle maintenance task.
- If you don't have the knowledge and equipment which are necessary to perform the maintenance task, consult your local KUBOTA Dealer.
- Have your local KUBOTA Dealer perform inspection items which are marked *4 in the chart below.

SERVICE INTERVALS

IMPORTANT :

- The jobs indicated by must be done after the first 50 hours of operation.
- *1 Air cleaner should be cleaned more often in dusty conditions than in normal conditions.
- *2 Every year or every 6 times of cleaning.
- *3 Replace only if necessary.
- *4 Consult your local KUBOTA Dealer for this service.
- *5 When the battery is used for less than 100 hours per year, check the battery condition by reading the indicator annually.
- The items listed below (@marked) are registered as emission related critical parts by KUBOTA in the U.S.EPA non road emission regulation. As the engine owner, you are responsible for the performance of the required maintenance on the engine according to the below instruction. Please see Warranty Statement in detail.

No.	Items		Indication of Hour Meter													After 700 hrs	Ref. Page		
			50	100	150	200	250	300	350	400	450	500	550	600	650				
1	Engine start system	Check														every 50 hrs	52		
2	Greasing	Apply														every 50 hrs	50		
3	Engine oil	Change														every 200 hrs	59		
4	Muffler [Spark arrester]	Clean														every 100 hrs	57		
5	Wheel bolt torque	Check														every 100 hrs	52		
6	Battery condition	Check														every 100 hrs	55	*5	
7	Alternator belt	Adjust														every 100 hrs	53		
8	VHT neutral spring	Check														every 100 hrs	52		
9	Toe-in	Adjust														every 100 hrs	56		
10	Fuel filter element	Check														every 100 hrs	54		@
		Replace														every 500 hrs	69	*4	
11	Air cleaner element	Clean														every 100 hrs	53	*1	@
		Replace														every 1 year	69	*2	

No.	Items		Indication of Hour Meter													After 700 hrs	Ref. Page			
			50	100	150	200	250	300	350	400	450	500	550	600	650					700
12	Fuel line	Check		○		○		○		○		○		○		○	every 100 hrs	54		@
		Replace																every 2 years	72	*3
13	Engine oil filter	Replace	●			○											every 200 hrs	58		
14	Transmission oil filter (HST) (Yellow color)	Replace	●			○											every 200 hrs	60		
15	Transmission oil filter (Suction) (Orange color)	Replace	●			○											every 200 hrs	61		
16	Brake pedal	Check	●			○											every 200 hrs	63	*4	
17	Parking brake lever	Adjust	●			○											every 200 hrs	58		
18	Brake light switch	Check	●			○											every 200 hrs	64		
19	Front brake case	Check	●			○											every 200 hrs	64		
20	Power steering oil	Change				○											every 200 hrs	66		
21	Hydraulic lift oil	Change				○											every 200 hrs	62		
22	Radiator hose and clamp	Check				○											every 200 hrs	65		
		Replace															every 2 years	72		
23	Power steering oil line	Check				○											every 200 hrs	65		
		Replace															every 2 years	72	*4	
24	Intake air line	Check				○											every 200 hrs	66		@
		Replace															every 2 years	72	*3	
25	Brake hose & pipe	Check	●			○											every 200 hrs	63		
		Replace															every 4 years	72	*4	
26	Tire wear	Check	●														every 300 hrs	67		
27	Transmission fluid	Change															every 400 hrs	68		
28	Front axle case oil	Change															every 400 hrs	69		
29	Knuckle case oil	Change															every 400 hrs	67		
30	Engine valve clearance	Adjust															every 800 hrs	69	*4	

No.	Items		Indication of Hour Meter													After 700 hrs	Ref. Page			
			50	100	150	200	250	300	350	400	450	500	550	600	650					700
31	Fuel injection nozzle Injection pressure	Check															every 1500 hrs	69	*4	@
32	Injection pump	Check															every 3000 hrs	69	*4	@
33	Brake Master cylinder (inner parts)	Replace															every 2 years	72	*4	
34	Brake fluid	Change															every 2 years	70	*4	
35	Remote hydraulic hose	Replace															every 2 years	72	*4	
36	Rear brake cylinder seal	Replace															every 2 years	72	*4	
37	Front brake seal	Replace															every 2 years	72	*4	
38	Cooling system	Flash															every 2 years	70		
39	Coolant	Change															every 2 years	70		
40	Fuel system	Bleed															Service as required	72		
41	Fuse	Replace														72				
42	Light bulb	Replace														74				

LUBRICANTS, FUEL AND COOLANT

No.	Locations	Capacities	Lubricants
1	Fuel	28 L	No. 2-D diesel fuel No. 1-D diesel fuel if temperature is below -10 °C
2	Coolant (with reserve tank)	4.0 L	Fresh clean water with anti-freeze
3	Engine crankcase	[Filter exchanged] 3.1 L	● Engine oil: API Service Classification CD, CE or CF
		[Filter non-exchanged] 2.7 L	Above 25 °C SAE30, SAE10W-30 or 15W-40
			0 to 25 °C SAE20, SAE10W-30 or 15W-40
		Below 0 °C SAE10W, SAE10W-30	
4	Transmission case	10 L	● KUBOTA UDT or SUPER UDT fluid*
5	Front axle case	0.6 L	● KUBOTA UDT or SUPER UDT fluid*
6	Knuckle case	Ref. 0.15 L	● KUBOTA UDT or SUPER UDT fluid*
7	Brake fluid (reservoir and lines)	0.4 L	KUBOTA DOT3 GENUINE BRAKE FLUID
8	Hydraulic lift oil	8.0 L	● KUBOTA UDT or SUPER UDT fluid*
9	Power steering oil	5.9 L	

Greasing	No. of greasing points	Capacity	Type of grease
Parking brake linkage	4	moderate amount	Multipurpose EP2 Grease (NLGI Grade No. 2)
Battery terminal	2		
Cargo lift cylinder pivot	2		
Cargo bed pivot	2		
VHT link	2	Until grease overflows	
Range gear shift lever pivot	1	moderate amount	
4WD lever pivot	2		
Rear drive shaft	2		
VHT pressure release	1		
Throttle cable	1		
			Antirust silicone grease

NOTE :

*KUBOTA UDT or SUPER UDT fluid --- KUBOTA original transmission hydraulic fluid

NOTE :

- Engine Oil:
Oil used in the engine should have an American Petroleum Institute (API) service classification and Proper SAE Engine Oil according to the ambient temperatures as shown above:
- Transmission oil:
The oil used to lubricate the transmission is also used as hydraulic fluid. To insure proper operation of the hydraulic system and complete lubrication of the transmission, it is important that a multi-grade transmission fluid be used in this system. We recommend the use of **KUBOTA UDT or SUPER UDT fluid** for optimum protection and performance. (Consult your local KUBOTA Dealer for further detail.)
Do not mix different brands or grades.
- Brake fluid:
Always use KUBOTA **DOT3 GENUINE BRAKE FLUID** from a sealed container. If it is not available, you should use only DOT3 fluid as a temporary replacement from a sealed container.
However, the use of any non-KUBOTA brake fluid can cause corrosion and decrease the life of the system.
Have the brake system flushed and refilled with KUBOTA **DOT3 GENUINE BRAKE FLUID** as soon as possible.
- Indicated capacity of water and oil are manufacturer's estimate.

PERIODIC SERVICE



CAUTION

To avoid personal injury:

- Do not work under any hydraulically supported devices. They can settle, suddenly leak down, or be accidentally lowered. If necessary to work under vehicle or any vehicle elements for servicing or adjustment, securely support them with stands or suitable blocking beforehand.

HOW TO OPEN THE HOOD AND TILT THE SEAT



CAUTION

To avoid personal injury from contact with moving parts;

- Never open the operator's seat while the engine is running.
- Support hood with other hand while unlocking support link.

■ Hood

To open the hood, pull up the latch lever to release the latch and open the hood.

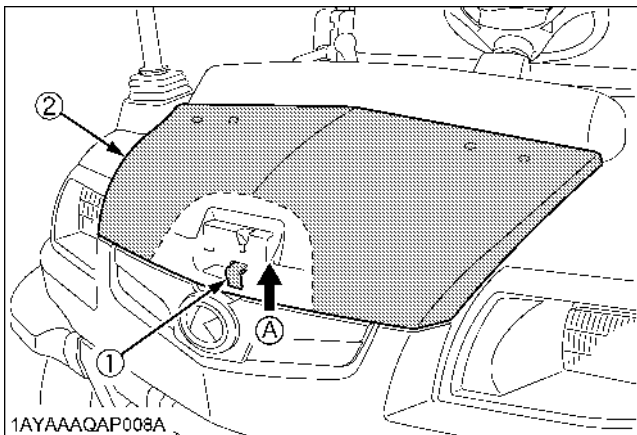

(1) Latch lever
(2) Hood

(A) "RELEASE"

NOTE :

- To close the hood, hold the hood and release the support link and press-fit the hood into position with both hands.

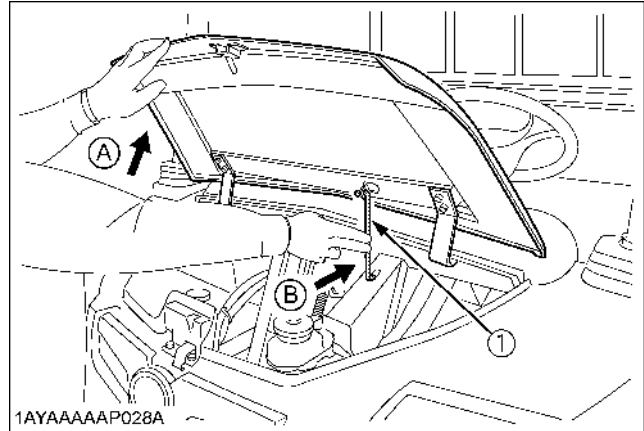

(1) Support link

(A) "HOLD"
(B) "PUSH"

■ Operator's Seat

To open the seat, release the seat lock lever and raise the seat to the forward position.

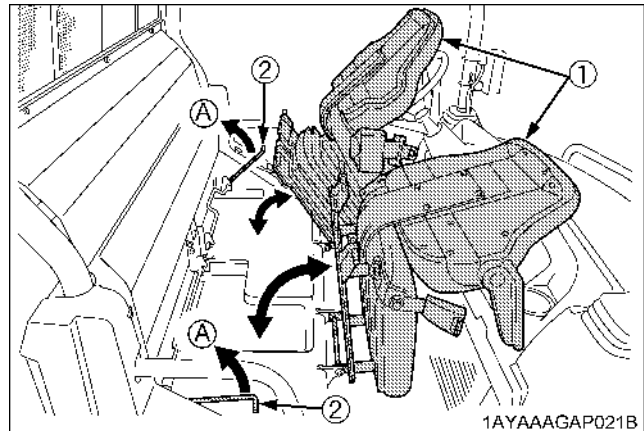

(1) Operator's seat
(2) Seat lock lever

(A) "RELEASE"

HOW TO RAISE THE CARGO BED



CAUTION

To avoid personal injury:

- When servicing under raised bed, make sure safety support is properly mounted.
- Do not touch muffler or exhaust pipes while they are hot; Severe burns could result.

■ Raising and Lowering the Cargo Bed

◆ To raise the cargo bed

1. Apply the parking brake and start the engine.
2. Release the restricting plate.
3. Pull up the hydraulic lift cylinder lever to raise the cargo bed.
4. When the cargo bed has been raised, return the lever to the "NEUTRAL" position.
5. Stop the engine.
6. Mount the safety support.

◆ To lower the cargo bed

1. Start the engine and then lift the bed slightly by operating the lever.
2. Remove the safety support and store it in the given location.
3. Lower the lever to the "DOWN" position to lower the bed.
4. After making sure that the bed has lowered to the lowest position, return the lever to the "NEUTRAL" position and lock it by the restricting plate.

NOTE :

- To raise or lower the cargo bed when the engine does not start or the hydraulics are not operating, shift the lever to the "FLOAT" position and raise or lower the bed manually.

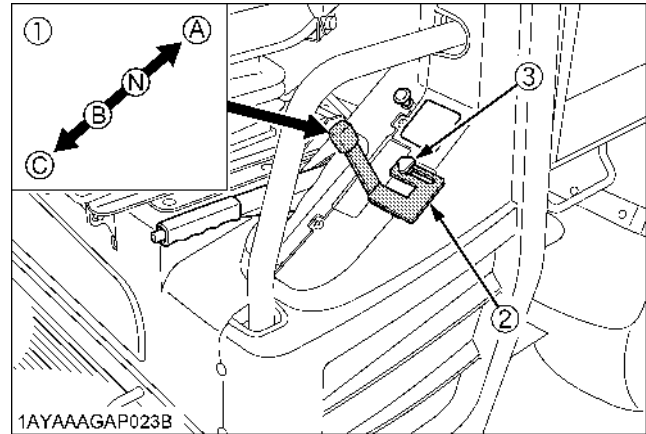

- | | |
|-----------------------------------|-------------------------|
| (1) Hydraulic lift cylinder lever | (A) "UP" |
| (2) Restricting plate | (N) "NEUTRAL" |
| (3) Knob bolt | (B) "DOWN" |
| | (C) "FLOAT with Detent" |

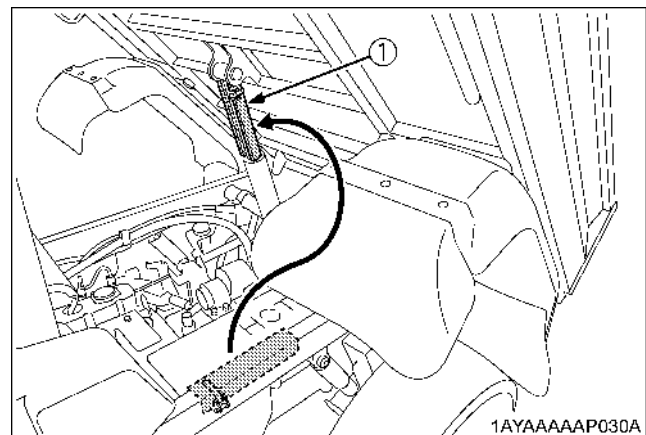

- (1) Safety support

JACK-UP POINT



WARNING

To avoid personal injury, death or vehicle damage:

- Do not work under the vehicle unless it is secured by safe stands or suitable blocking.

■ Front End

Jack up at the front bumper only.

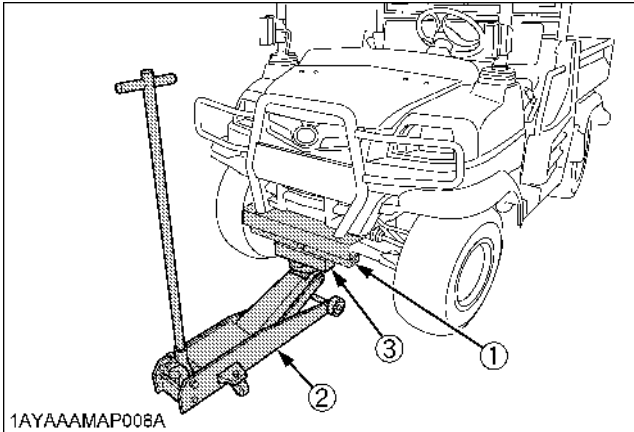

- (1) Front bumper
- (2) Jack
- (3) Wooden block

■ Rear End

Jack up the rear side after placing a wooden block under the right and left pipe frames for securing the engine and then supporting it.

Do not jack it up supporting the steel plate portion under the engine directly.

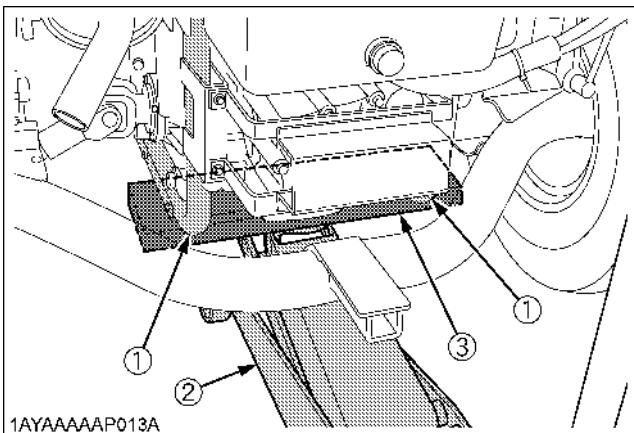

- (1) Pipe frame
- (2) Jack
- (3) Wooden block

DAILY CHECK

For your own safety and maximum service life of the vehicle, make a thorough daily inspection before operating the vehicle to start the engine.



CAUTION

To avoid personal injury:

- Be sure to check and service the vehicle on a flat surface with the engine shut off and the parking brake "ON".

■ Walk Around Inspection

Look around and under the vehicle for such items as loose bolts, trash build-up, oil or coolant leaks, broken or worn parts.

■ Checking and Refueling



CAUTION

To avoid personal injury:

- Do not smoke while refueling.
- Be sure to stop the engine before refueling.

1. Turn the key switch to "ON", check the amount of fuel by fuel gauge.
2. Fill fuel tank when fuel gauge shows 1/4 or less fuel in tank.
3. Use grade No.2-Diesel fuel at temperatures above -10 °C.
Use grade No.1-Diesel fuel at temperatures below -10 °C.

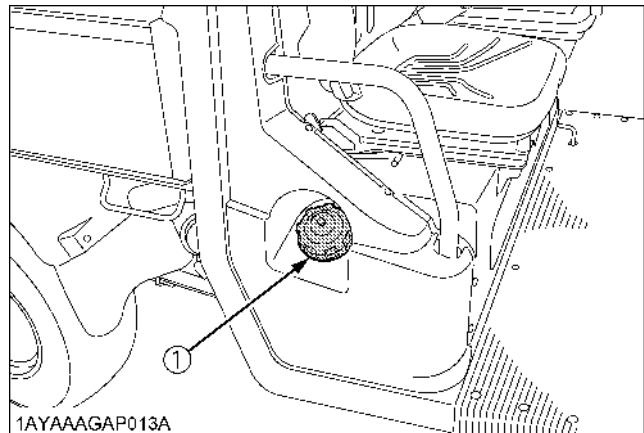

- (1) Fuel tank cap

Fuel tank capacity	28 L
--------------------	------

IMPORTANT :

- Do not permit dirt or trash to get into the fuel system.
- Be careful not to let the fuel tank become empty, otherwise air will enter the fuel system, necessitating bleeding before next engine start.
- Be careful not to spill during refueling. If should spill, wipe it off at once, or it may cause a fire.
- To prevent water condensation from accumulating in the fuel tank, fill the tank before parking overnight.

NOTE :

- No.2-D is a distillate fuel of lower volatility for engines in industrial and heavy mobile service. (SAE J313 JUN87)
- Grade of Diesel Fuel Oil According to ASTM D975.

Flash Point, °C	Water and Sediment, volume %	Carbon Residue on, 10 percent Residuuum, %	Ash, weight %
Min.	Max.	Max.	Max.
52	0.05	0.35	0.01

Distillation Temperatures, °C 90% Point		Viscosity Kinematic cSt or mm ² /s at 40 °C		Viscosity Saybolt, SUS at 100 °F	
Min.	Max.	Min.	Max.	Min.	Max.
282	338	1.9	4.1	32.6	40.1

Sulfur weight %	Copper Strip Corrosion	Cetane Number
Max.	Max.	Min.
0.50	No.3	40

Checking Engine Oil Level



CAUTION

To avoid personal injury:

- Be sure to stop the engine before checking the oil level.

1. Park the vehicle on a flat surface and raise the cargo bed.
2. Check engine oil before starting the engine or 5 minutes or more after the engine has stopped.
3. To check the oil level, draw out the dipstick, wipe it clean, replace it, and draw it out again. Check to see that the oil level lies between the two notches. If the level is too low, add new oil to the prescribed level at the oil inlet.

(See "LUBRICANTS, FUEL AND COOLANT" in "MAINTENANCE" section.)

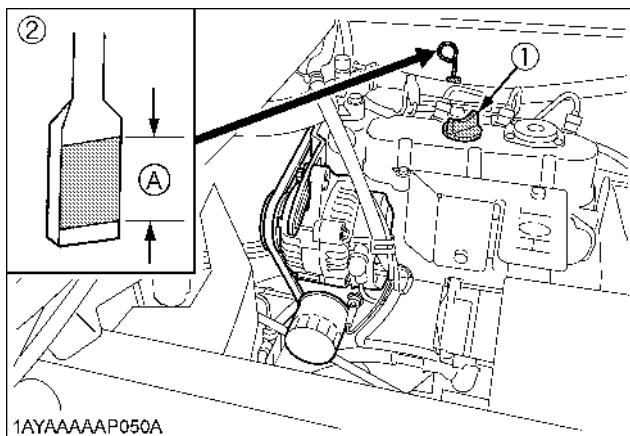

1AYAAAAAP050A

- (1) Oil inlet (A) Oil level is acceptable within this range.
 (2) Dipstick

IMPORTANT :

- When using an oil of different maker or viscosity from the previous one, remove all of the old oil. Never mix two different types of oil.
- If oil level is low, do not run engine.

■ Checking Transmission Fluid Level

1. Park the vehicle on a flat surface, raise the cargo bed and shut off engine.
2. To check the oil level, draw out the dipstick, wipe it clean, replace it, and draw it out again. Check to see that the oil level lies between the two notches.
If the level is too low, add new oil to the prescribed level at the oil inlet.
(See "LUBRICANTS, FUEL AND COOLANT" in "MAINTENANCE" section.)

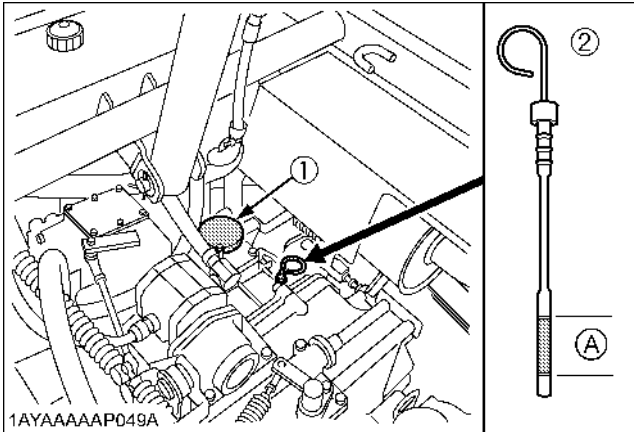

(1) Oil inlet (A) Oil level is acceptable within this range.
(2) Dipstick

IMPORTANT :

- If oil level is low, do not run engine.

■ Checking Power Steering Oil Tank Level

1. Park the vehicle on a flat surface.
2. Check to see that the oil level is between the "H" and "L" marks on the oil tank.
If the level is too low, add new oil to the "H" mark.
(See "LUBRICANTS, FUEL AND COOLANT" in "MAINTENANCE" section.)

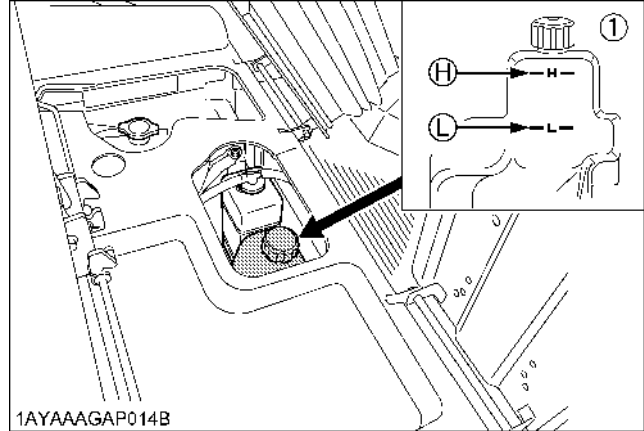

(1) Power steering oil tank (H) "HIGH"
(L) "LOW"

IMPORTANT :

- If oil level is low, do not run engine.

■Checking Hydraulic Lift Oil Tank Level

1. Park the vehicle on a flat surface.
2. Raise the cargo bed and mount the safety support.
(See "HOW TO RAISE THE CARGO BED" in "PERIODIC SERVICE" section.)
3. To check the oil level, remove the dipstick, wipe it clean, screw it into filling hole and remove dipstick again.
If the level is too low, add new oil to the prescribed level at the oil inlet.
(See "LUBRICANTS, FUEL AND COOLANT" in "MAINTENANCE" section.)

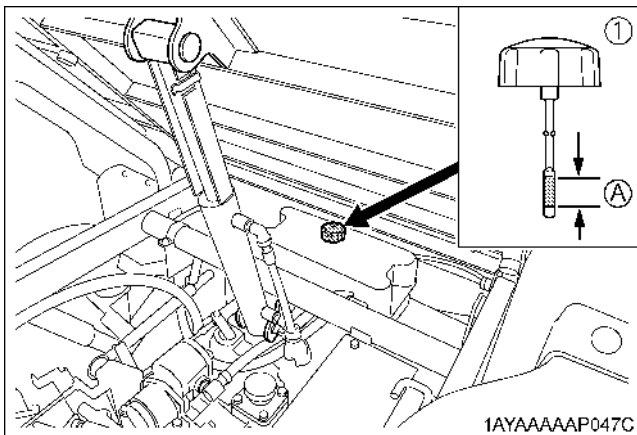

(1) Filling plug with dipstick (A) Oil level is acceptable within this range

IMPORTANT :

- If oil level is low, do not run engine.

■Checking Coolant Level



CAUTION

To avoid personal injury:

- Do not remove radiator cap while coolant is hot. When cool, slowly rotate cap to the first stop and allow sufficient time for excess pressure to escape before removing the cap completely.

1. Park the vehicle on a flat surface and raise the seat.
2. Check to see that the coolant level is between the "FULL" and "LOW" marks of recovery tank.
3. When the coolant level drops due to evaporation, add water only up to the full level.
In case of leakage, add anti-freeze and water in the specified mixing ratio up to the full level.
(See "Flush Cooling System and Changing Coolant" in "EVERY 2 YEARS" in "PERIODIC SERVICE" section.)

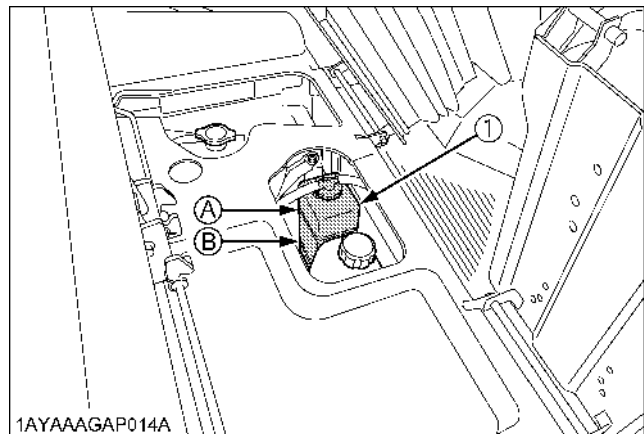

(1) Recovery tank (A) "FULL" (B) "LOW"

IMPORTANT :

- If the radiator cap has to be removed, follow the caution above and securely retighten the cap.
- Use clean, fresh water and anti-freeze to fill the recovery tank.
- If water should leak, consult your local KUBOTA Dealer.

■ Cleaning Radiator Screen



CAUTION

To avoid personal injury:

- Be sure to stop the engine before removing the screen.

1. Park the vehicle on a flat surface and raise the seat.
2. Detach the screen and remove all foreign materials.

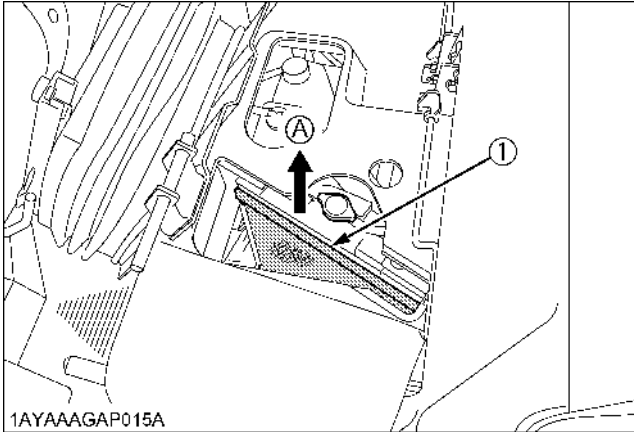

(1) Radiator screen

(A) "DETACH"

IMPORTANT :

- Radiator screen must be clean from debris to prevent engine from overheating.

■ Checking Brake Fluid Level



CAUTION

To avoid personal injury:

- Never operate the vehicle, if the brake fluid is below the "MIN" mark.
- Use only KUBOTA DOT3 GENUINE BRAKE FLUID from a sealed container. Using other type of oil ruins synthetic resin or rubber installed in brake system components, and may cause brake failure.
- Avoid contamination of the brake fluid. Thoroughly clean area around the filler cap before removing. Do not open the brake fluid reservoir cap unless absolutely necessary.
- Use extreme care when filling the reservoir. If brake fluid is spilled on power steering hose, wash off with water immediately. Brake fluid quickly ruins synthetic resin or rubber hoses.

1. Park the vehicle on level ground and open hood.
2. Check to see that the brake fluid level is between the "MAX" and "MIN" marks.
3. If it is below the "MIN" mark, add brake fluid to the "MAX" mark.

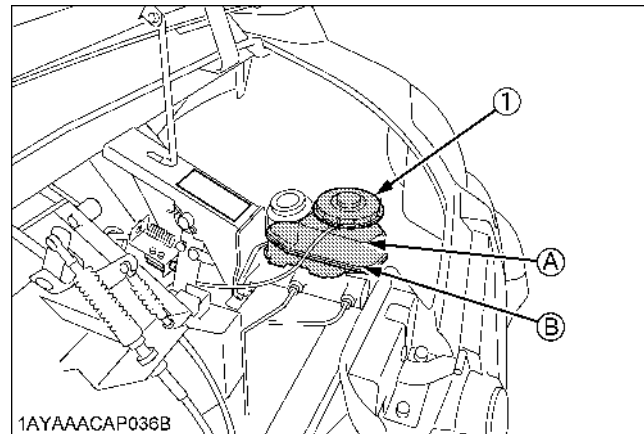

(1) Oil tank cap

(A) "MAX"

(B) "MIN"

■ **Checking Brake Pedal**



CAUTION

To avoid personal injury:

- Stop the engine and chock the wheels before checking brake pedal.

1. Inspect the brake pedals for free travel, and smooth operation.
2. Adjust if incorrect measurement is found: (See "Checking Brake Pedal" in "EVERY 200 HOURS" in "PERIODIC SERVICE" section.)

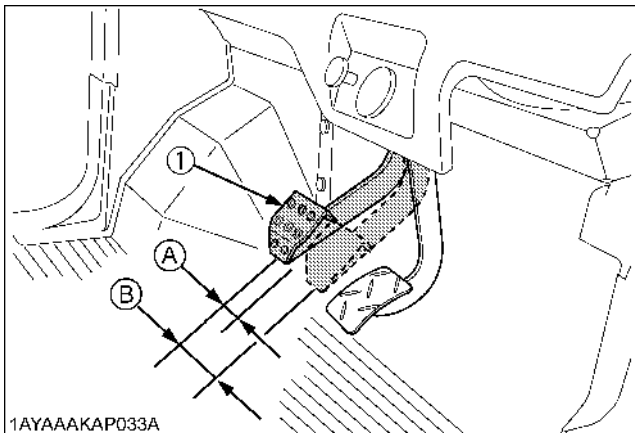

(1) Brake pedal

(A) "FREE TRAVEL"

(B) "PEDAL STROKE"

■ **Checking Parking Brake**

Pull the parking brake lever to apply the brakes. With the key switch at "ON" position, the parking brake indicator on the instrument panel lights up. To release the brakes, push in the button at the tip of the parking brake lever and tilt down the lever.

NOTE :

- Make sure the parking brake warning lamp (ⓘ) on the Easy Checker(TM) goes off when parking brake lever is down.

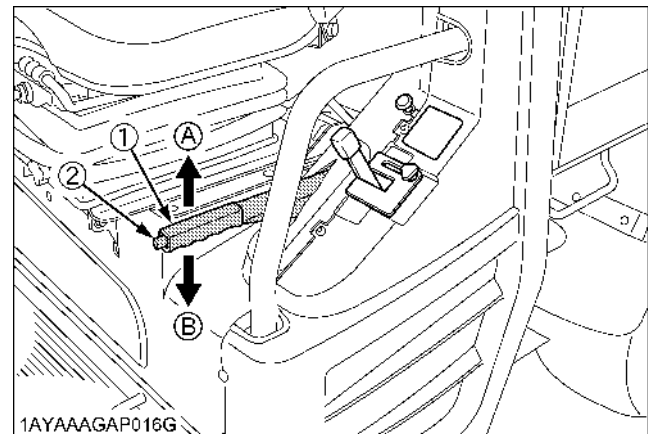

(1) Parking brake lever

(2) Release button

(A) "PULL"

(B) "RELEASE"

■ **Checking Gauges, Meter and Easy Checker(TM)**

1. Inspect the instrument panel for broken gauge(s), meter(s) and Easy Checker(TM) lamps.
2. Replace if broken.

■ **Checking Head Light, Turn Signal Light etc.**

1. Inspect the lights for broken bulbs and lenses.
2. Replace if broken.

■ **Checking Seat Belt and ROPS**

1. Always check condition of seat belt and ROPS attaching hardware before operating vehicle.
2. Replace if damaged.

■ Checking Joint Boot

1. Check to see if the joint boots are not damaged.
2. If the boots are cuts, cracked or shows signs of deterioration, consult your local KUBOTA Dealer.

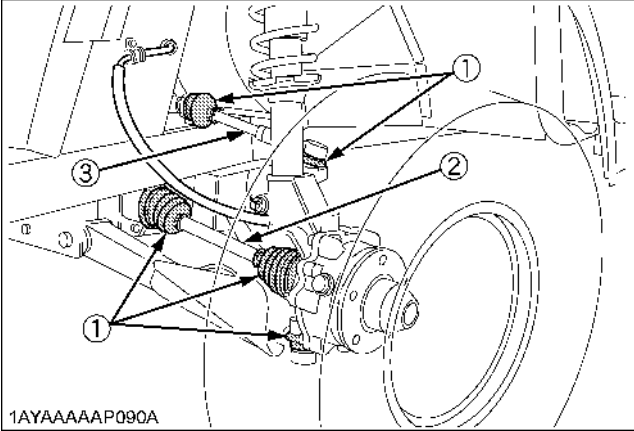

- (1) Joint boot
- (2) Front drive shaft
- (3) Tie rod

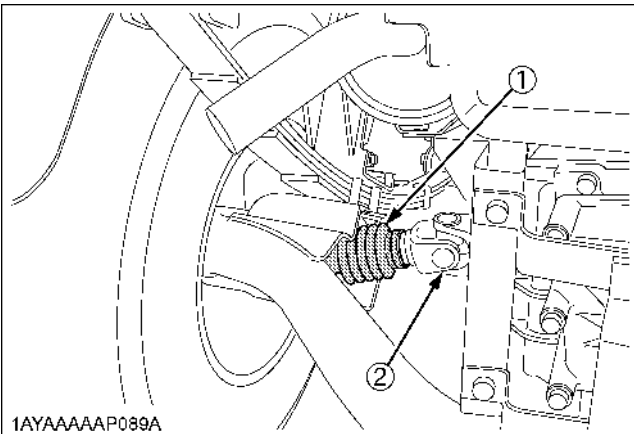

- (1) Joint boot
- (2) Rear drive shaft

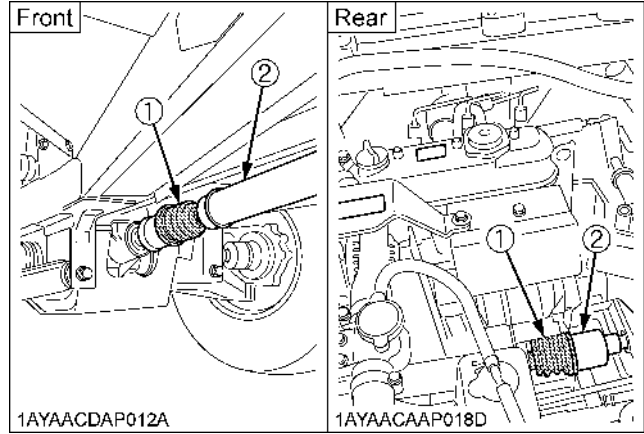

- (1) Joint boot
- (2) Drive shaft

■ Checking Tire Inflation Pressure

Though the tire pressure is factory-set to the prescribed level, it naturally drops slowly in the course of time. Thus, check it everyday and inflate as necessary.

Tire sizes	Inflation Pressure
25 x 10 - 12 HDWS, Front & Rear	140 kPa (1.4 kgf/cm ²)
25 x 10 - 12 ATV, Front	
25 x 11 - 12 ATV, Rear	

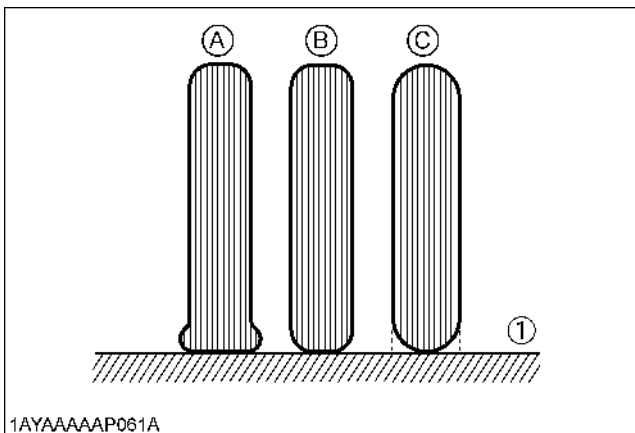

(1) Ground

- (A) "INSUFFICIENT"
- (B) "NORMAL"
- (C) "EXCESSIVE"

■ Checking Backup Beeper

[if equipped]

1. Sit on the operator's seat.
2. Set the parking brake and stop the engine.
3. Shift the range gear shift lever to the "NEUTRAL" position.
4. Turn the key to "ON" position.
5. Shift the range gear shift lever to the "REVERSE" position.
6. If the backup beeper does not beep, consult your local KUBOTA Dealer.

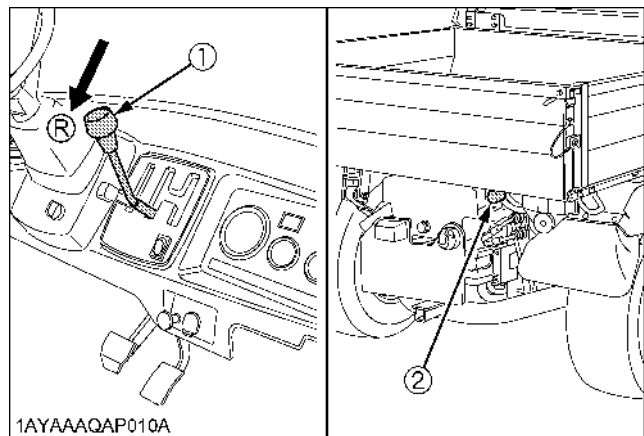

(1) Range gear shift lever

(2) Backup beeper (if equipped)

(R) "REVERSE"

EVERY 50 HOURS

■ Greasing

Apply a small amount of multi-purpose grease to the following points every 50 hours: If you operated the vehicle in extremely wet and muddy conditions, lubricate grease fittings more often.

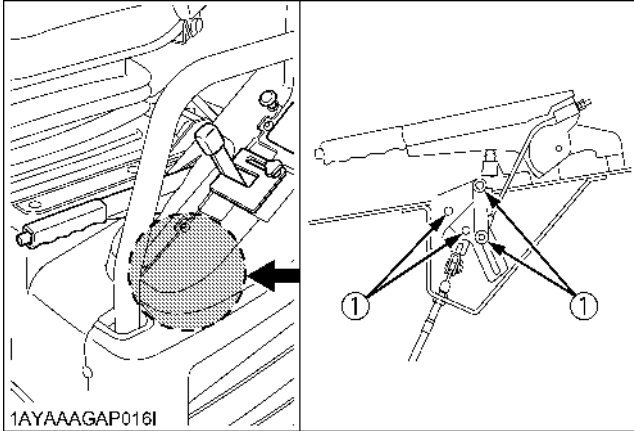

1AYAAAGAP016I

(1) Parking brake pivot (spray type grease)

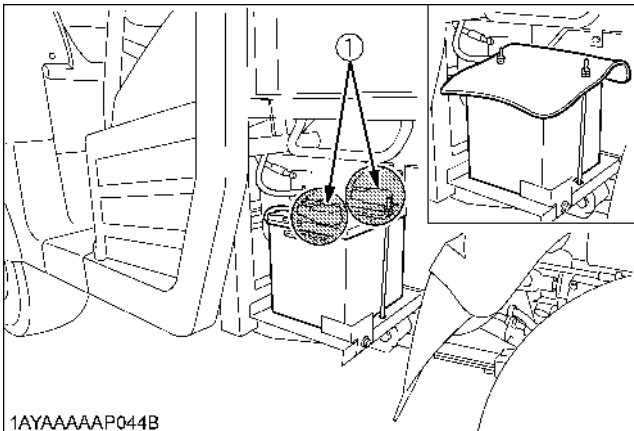

1AYAAAAAP044B

(1) Battery terminals

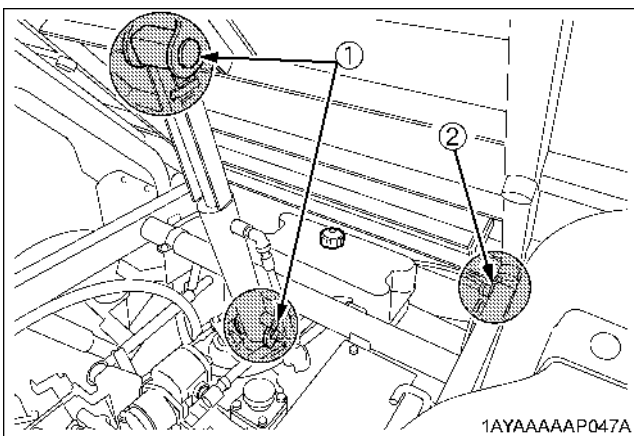

1AYAAAAAP047A

(1) Cargo lift cylinder pivot (spray type grease)
(2) Cargo bed pivot (spray type grease)

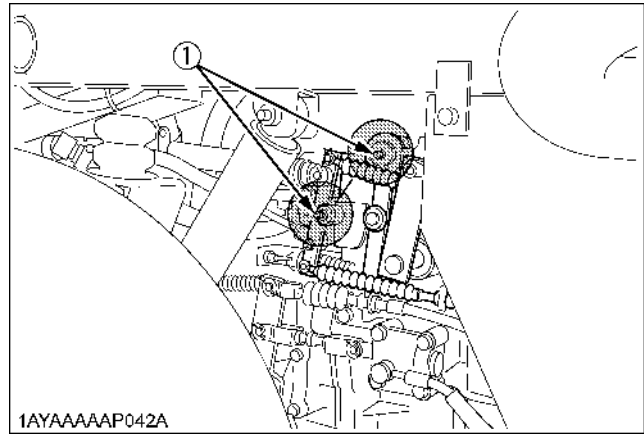

1AYAAAAAP042A

(1) VHT link (Grease fitting)

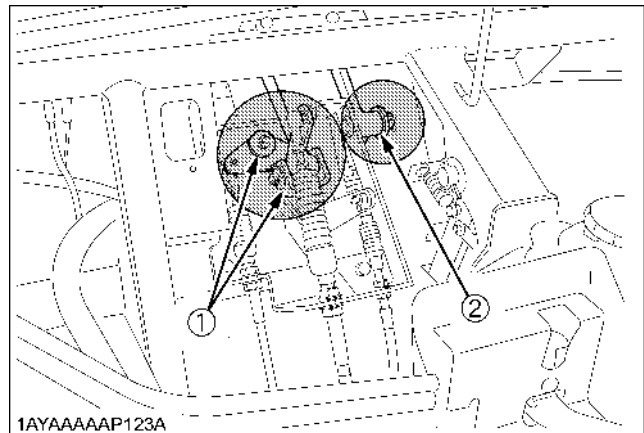

1AYAAAAAP123A

(1) Range gear shift lever pivot (spray type grease)
(2) 4WD lever pivot (spray type grease)

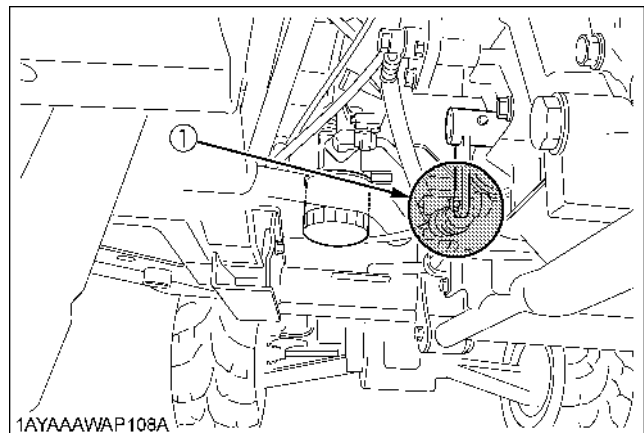

1AYAAAWAP108A

(1) 4WD lever pivot (spray type grease)

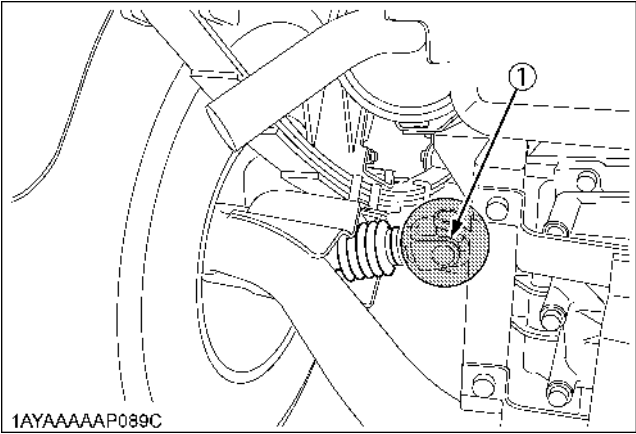

1AYAAAAAP039C

(1) Rear drive shaft (Grease fitting)

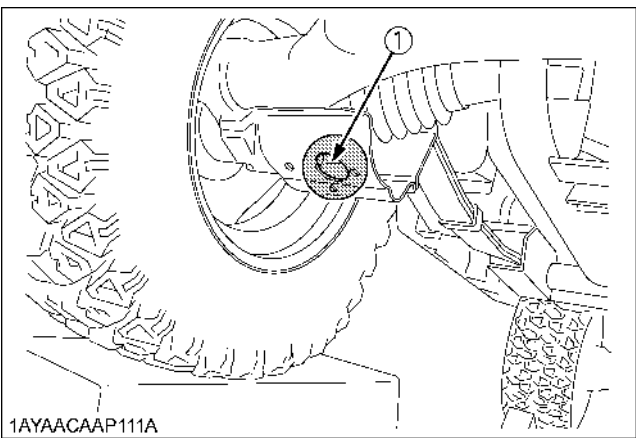

1AYAAAP111A

(1) Rear drive shaft (Grease fitting)

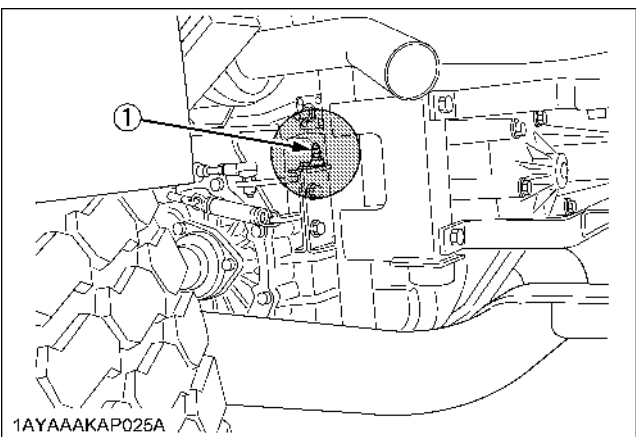

1AYAAKAP025A

(1) VHT pressure release (Grease fitting)

■ Oiling

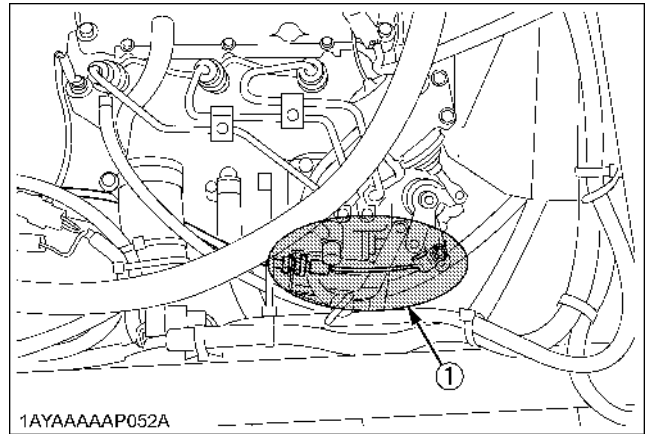

1AYAAAAAP052A

(1) Accelerator wire

■ Checking Engine Start System



CAUTION

To avoid personal injury:

- Do not allow anyone near the vehicle while testing.
- If the vehicle does not pass the test do not operate the vehicle.

◆ Preparation before testing.

1. Place all control levers in the "NEUTRAL" position.
2. Set the parking brake and stop the engine.

◆ Test: Range gear shift lever safety switch

1. Sit on the operator's seat.
2. Shift the range gear shift lever to H, M, L or reverse position.
3. Return the Speed control pedal to the "NEUTRAL" position.
4. Shift the hydraulic lift cylinder lever to the "NEUTRAL" position.
5. Turn the key to "START" position.
6. The engine must not crank.
7. If it cranks, consult your local KUBOTA Dealer for service.

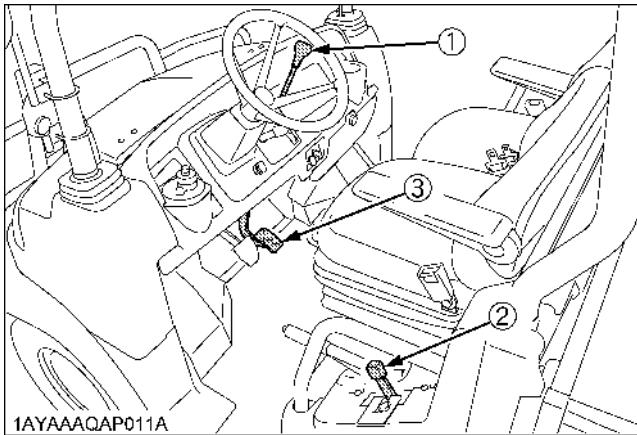

1AYAAAQAP011A

- (1) Range gear shift lever
- (2) Hydraulic lift cylinder lever
- (3) Speed control pedal

EVERY 100 HOURS

■ Checking VHT Neutral Spring

1. Park the vehicle on a flat place.
2. Set the parking brake.
3. Shift the range gear shift lever to the "NEUTRAL" position.
4. Lock the hydraulic lift cylinder lever to the "NEUTRAL" position with restricting plate.
5. Start the engine.
6. Make sure that the rotation speed of the engine returns to the idling rotation immediately when taking the foot off the pedal, after depressing the speed control pedal several times. If the above does not occur immediately, consult your local KUBOTA dealer for this service.

■ Checking Wheel Bolt Torque



CAUTION

To avoid personal injury:

- Never operate vehicle with a loose wheel bolts.
- Any time bolts are loosened, retighten to the specified torque.
- Check all bolts frequently and keep them tight.

Check wheel bolts regularly especially when new. If they are loose, tighten them as follows.

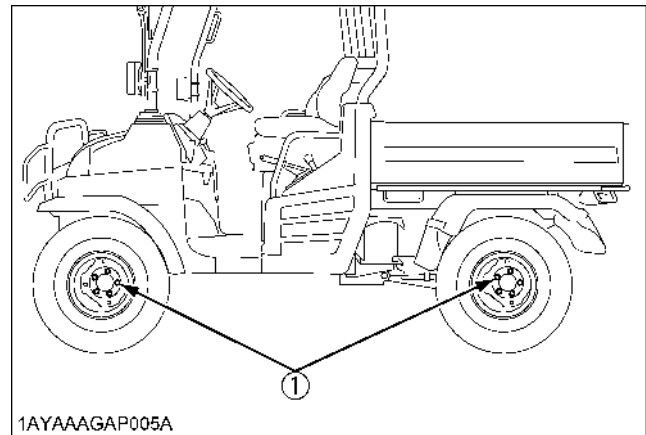

1AYAAAGAP005A

- (1) Torque wheel bolts to 75 to 90 N-m (7.6 to 9.2 kgf-m)

■ Cleaning Air Cleaner Primary Element

- Remove the air cleaner cover and primary element.
- Clean the primary element:
 - When dry dust adheres to the element, blow compressed air from the inside, turning the element. Pressure of compressed air must be under 205 kPa (2.1 kgf/cm²).
 - When carbon or oil adheres to the element, soak the element in detergent for 15 minutes then wash it several times in water, rinse with clean water and dry it naturally. After element is fully dried, inspect inside of the element with a light and check if it is damaged or not.
- Replace the primary element:
Once yearly or after every sixth cleaning, whichever comes first.

NOTE :

- Check to see if the evacuator valve is blocked with dust.
- Check the rubber seal. Replace if damaged.

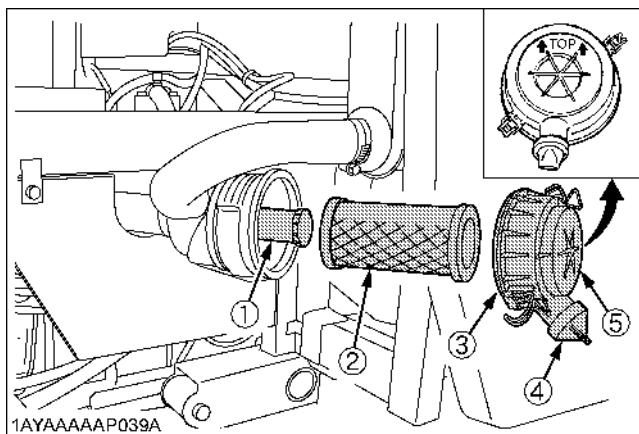

- | | |
|--------------------------------|---------------------|
| (1) Secondary (safety) element | (4) Evacuator valve |
| (2) Primary element | (5) Cover |
| (3) Rubber seal | |

IMPORTANT :

- The air cleaner uses a dry element, never apply oil.
- Do not run the engine with filter element removed.
- Be sure to refit the cover with the arrow (on the rear of cover) upright. If the cover is improperly fitted, evacuator valve will not function and dust will adhere to the element.
- Do not touch the secondary element except in cases where replacing is required.
(See "Replacing Air Cleaner Secondary Element" in "EVERY 1 YEAR" in "PERIODIC SERVICE" section.)

◆ Evacuator Valve

Open the evacuator valve once a week under ordinary conditions - or daily when used in a dusty place - to get rid of large particles of dust and dirt.

■ Adjusting Alternator Belt Tension



CAUTION

To avoid personal injury:

- Be sure to stop the engine before checking belt tension.

Proper alternator belt tension	A deflection of between 7 to 9 mm when the belt is pressed in the middle of the span.
--------------------------------	---

- Park the vehicle on a flat surface and raise the cargo bed.
- Stop the engine and remove the key.
- Apply moderate thumb pressure to belt between pulleys.
- If tension is incorrect, loosen the alternator mounting bolts and, using a lever placed between the alternator and the engine block, pull the alternator out until the deflection of the belt falls within acceptable limits.
- Replace alternator belt if it is damaged.

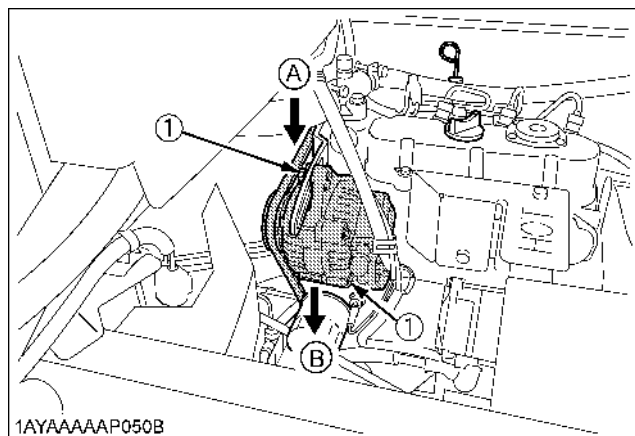

- | | |
|----------|----------------------------|
| (1) Bolt | (A) Check the belt tension |
| | (B) To tighten |

■ Checking Fuel Line and Fuel Filter



CAUTION

To avoid personal injury:

- Be sure to stop the engine and remove the key when attempting to make the following checks and changes.
- Never fail to check the fuel lines periodically. The fuel lines are subject to wear and aging. Fuel may leak out onto the running engine, causing a fire.

The fuel line connections should be checked annually or every 100 service hours, whichever comes first.

1. Park the vehicle on a flat surface and raise the cargo bed.
2. The fuel line is made of rubber and ages regardless of service period.
3. If the fuel line and clamps are found to be damaged or deteriorated, replace them.
4. Check fuel filter, if it is clogged by debris or contaminated with water, replace it.

IMPORTANT :

- When the fuel line is disconnected for maintenance or repair, close both ends of the fuel line with a piece of clean cloth or paper to prevent dust and dirt from entering. In addition, particular care must be taken not to admit dust and dirt into the fuel pump. Entrance of even a small amount of dust or dirt cause premature wear and malfunction of the fuel pump and injector components.

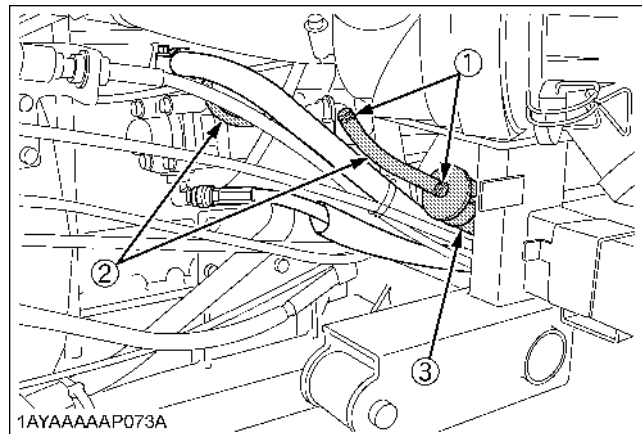
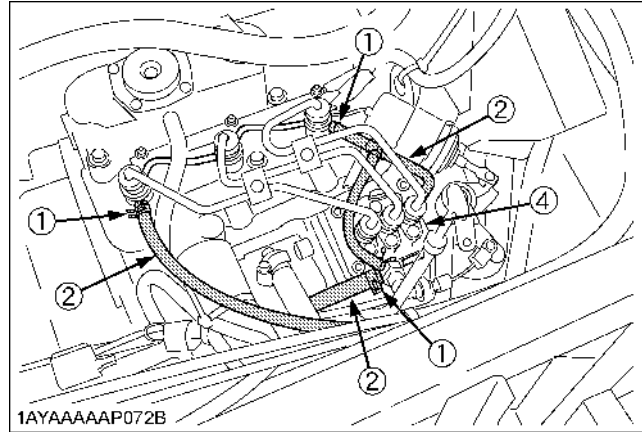

- (1) Pipe clamps
- (2) Fuel line
- (3) Fuel filter
- (4) Fuel pump

■ Checking Battery Condition

! DANGER

To avoid the possibility of battery explosion:
For the refillable type battery, follow the instructions below.

- Do not use or charge the refillable type battery if the fluid level is below the LOWER (lower limit level) mark. Otherwise, the battery component parts may prematurely deteriorate, which may shorten the battery's service life or cause an explosion. Check the fluid level regularly and add distilled water as required so that the fluid level is between the UPPER and LOWER levels.

! CAUTION

To avoid personal injury:

- Never remove the vent caps while the engine is running.
- Keep electrolyte away from eyes, hands and clothes. If you are splattered with it, wash it away completely with water immediately and get medical attention.
- Wear eye protection and rubber gloves when working around the battery.

The factory-installed battery is of non-refillable type. If the battery is weak, charge the battery or replace it with new one.

◆ Battery Charging

! CAUTION

To avoid personal injury:

- When the battery is being activated, hydrogen and oxygen gases in the battery are extremely explosive. Keep open sparks and flames away from the battery at all times, especially when charging the battery.
- When charging the battery, ensure the vent caps are securely in place. (if equipped)
- When disconnecting the cable from the battery, start with the negative terminal first. When connecting the cable to the battery, start with the positive terminal first.
- Never check battery charge by placing a metal object across the posts.
Use a voltmeter or hydrometer.

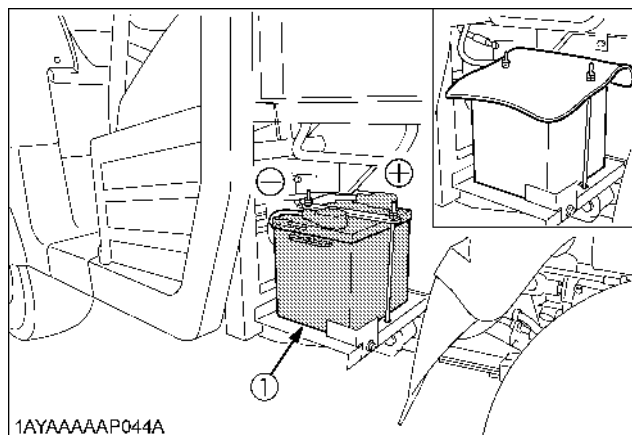

1AYAAAAAP044A

(1) Battery

1. To slow charge the battery, connect the battery positive terminal to the charger positive terminal and the negative to the negative, then recharge in the standard fashion.
2. A boost charge is only for emergencies. It will partially charge the battery at a high rate and in a short time. When using a boost-charged battery, it is necessary to recharge the battery as early as possible. Failure to do this will shorten the battery's service life.
3. When exchanging an old battery for a new one, use battery of equal specification shown in table 1.

Battery TYPE	Volts (V)
526RA	12

Reserve Capacity (min)	Cold Cranking Amps	Normal Charging Rate (A)
80	535	6.5

◆ Direction for Storage

1. When storing the vehicle for a long period, remove the battery from vehicle, adjust the electrolyte to the proper level (refillable type only) and store in a dry place out of direct sunlight.
2. The battery self-discharges while it is stored. Recharge it once every three months in hot seasons and once every six months in cold seasons.

■ Adjusting Toe-in

Proper toe-in	0 to 20 mm
---------------	------------

1. Park vehicle on a flat place.
2. Turn steering wheel so front wheels are in the straight ahead position.
3. Lock the park brake and stop the engine.
4. Measure distance between tire beads at front of tire, at hub height.
5. Measure distance between tire beads at rear of tire, at hub height.
6. Front distance should be shorter than rear distance. If not, adjust tie rod length.

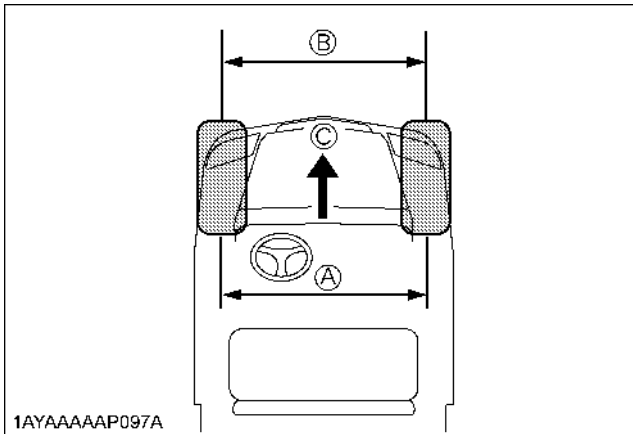

- (A) Wheel - to - wheel distance at rear
 (B) Wheel - to - wheel distance at front
 (C) "FRONT"

◆ Adjusting procedures

1. Loosen the lock nut and turn the tie rod to adjust the rod length until the proper toe-in measurement is obtained.
2. Retighten the lock nut.

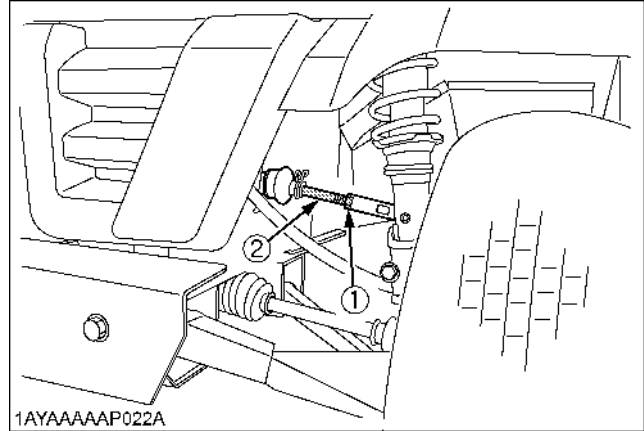

- (1) Lock nuts
 (2) Tie-rod

IMPORTANT :

- Keep the length of the left and right tie-rod equal.

■ **Cleaning Muffler**

CAUTION

To avoid personal injury:

- Before touching any part of an exhaust system, be absolutely sure that it has sufficient time to cool !
- Always wear safety goggles and a (face) mask.
- The particulate matter contained in the muffler contains chemicals that are harmful to people, animals and marine life.
- If you are unable to do this work, have it done by your KUBOTA Dealer.

◆ **Cleaning spark arrester of muffler**

This screen type spark arrester was examined, tested, and qualified in accordance with the USDA Forest Service Standard 5100-1c, "Spark Arresters for Internal Combustion Engines" for the RTV900.

Maintenance & cleanout procedure:

The screen type spark arrester should be removed, cleaned, and inspected after every 100 hours of use.

1. The spark arrester is located inside of the exhaust pipe, and is fastened with two bolts.
2. Unfasten the bolts and remove the spark arrester.
3. Shake loosened particles out of the screen assembly and lightly clean the screen with wire brush. Soak in solvent and again clean with wire brush if necessary.
4. If any breaks in the screen or weldments are discovered, the assembly must be replaced.
5. Return the spark arrester to the muffler body and refasten the bolts.

IMPORTANT :

- Visually check the muffler for cracks or holes in the body, weldment or pipes at regular intervals.
- USDA approval requires clearance between spark arrester sleeve and exhaust pipe to be no larger than 0.584 mm.
- Replace the entire muffler if it is damaged.
- Do not operate the vehicle with a damaged muffler.

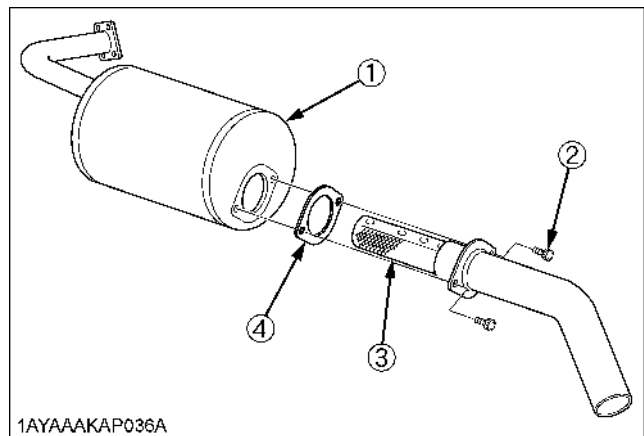
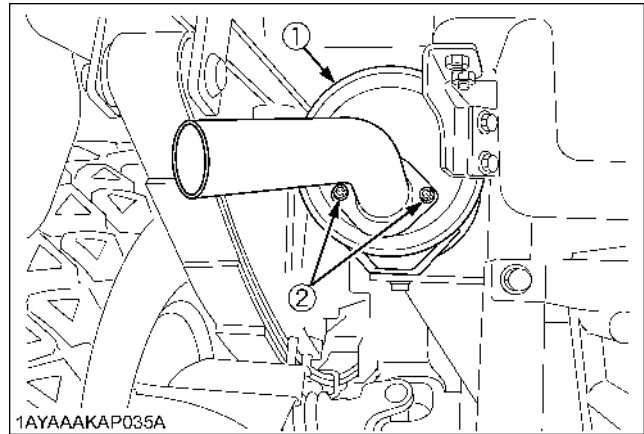

- (1) Muffler
- (2) Bolt
- (3) Spark arrester
- (4) Gasket

EVERY 200 HOURS

■ Adjusting Parking Brake

Proper parking brake lever free play range	1 notch
--	---------

◆ Adjusting procedure

1. Release the parking brake.
2. Loosen the lock nut, and adjust the cable wire length.
3. Tighten the lock nut, and check the free play.

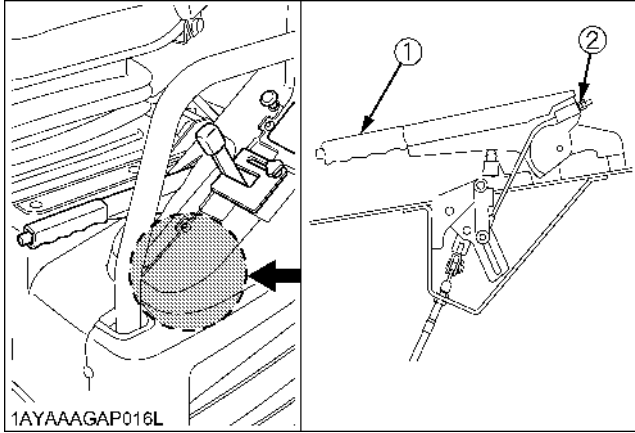

- (1) Parking brake lever
(2) Lock nut

■ Replacing Engine Oil Filter



CAUTION

To avoid personal injury:

- Be sure to stop the engine before changing the oil filter.
- Allow engine to cool down sufficiently, oil can be hot and can burn.

1. Park the vehicle on a flat surface and raise the cargo bed.
2. Remove the oil filter.
3. Put a film of clean engine oil on the rubber seal of the new filter.
4. Tighten the filter quickly until it contacts the mounting surface.
Tighten filter by hand an additional 1/2 turn only.
5. After the new filter has been replaced, the engine oil normally decreases a little. Make sure that the engine oil does not leak through the seal and be sure to check the oil level on the dipstick. Then, replenish the engine oil up to the prescribed level.

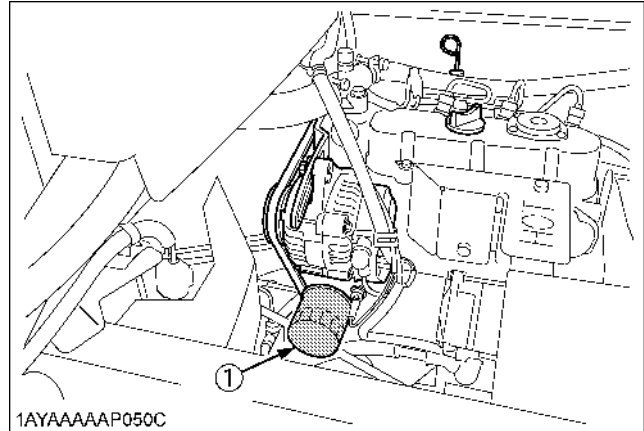

- (1) Engine oil filter

IMPORTANT :

- To prevent serious damage to the engine, use only a KUBOTA genuine filter.

■ Changing Engine Oil

CAUTION

To avoid personal injury:

- Be sure to stop the engine before changing the oil.
- Allow engine to cool down sufficiently, oil can be hot and can burn.

1. Park the vehicle on a flat surface and raise the cargo bed.
2. To drain the used oil, remove the drain plug at the bottom of the engine and completely drain the oil into an oil pan.
All the used oil can be drained out easily when the engine is still warm.
3. After draining, reinstall the drain plug.
4. Fill with the new oil up to the upper notch on the dipstick.
(See "LUBRICANTS, FUEL AND COOLANT" in "MAINTENANCE" section.)

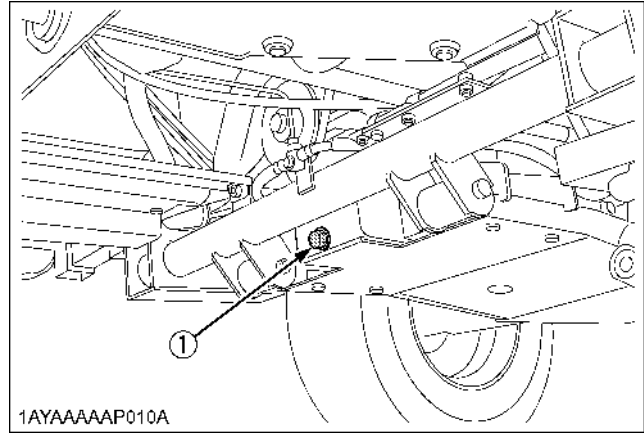

(1) Drain plug

Oil capacity	3.1 L [Filter exchanged] 2.7 L [Filter non-exchanged]
--------------	--

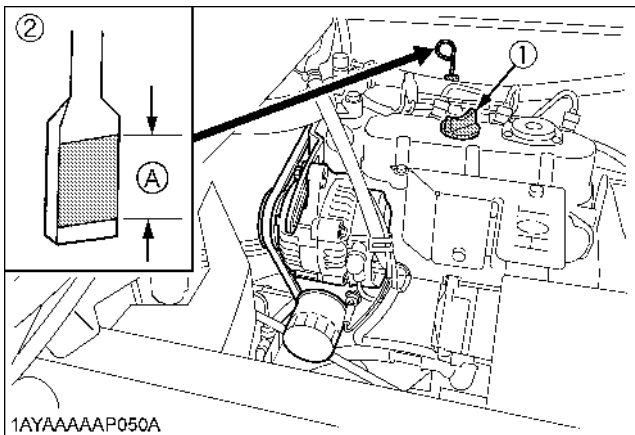

(1) Oil inlet (A) Oil level is acceptable within this range
(2) Dipstick

■ Replacing Transmission Oil Filter [HST]



CAUTION

To avoid personal injury:

- Be sure to stop the engine before changing the oil filter.
- Allow engine to cool down sufficiently, oil can be hot and can burn.

1. Park the vehicle on a flat surface, raise the cargo bed and mount the safety support.
2. Remove the oil filters.
3. Put a film of clean transmission oil on the rubber seal of the new filter.
4. Quickly tighten the filter until it contacts the mounting surface, then, with a filter wrench, tighten it an additional 1 turn only.
5. After the new filter has been replaced, fill the transmission oil up to the upper notch on the dipstick.
6. After running the engine for a few minutes, stop the engine and check the oil level again, add oil to the prescribed level.
7. Make sure that the transmission fluid doesn't leak past the seal on the filters.

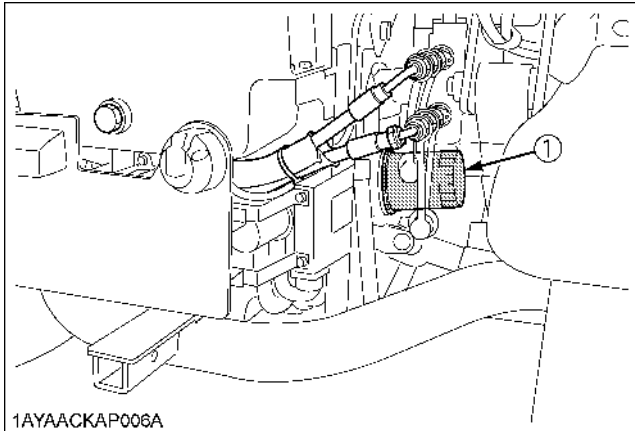

(1) Transmission oil filter (HST) (Yellow color)

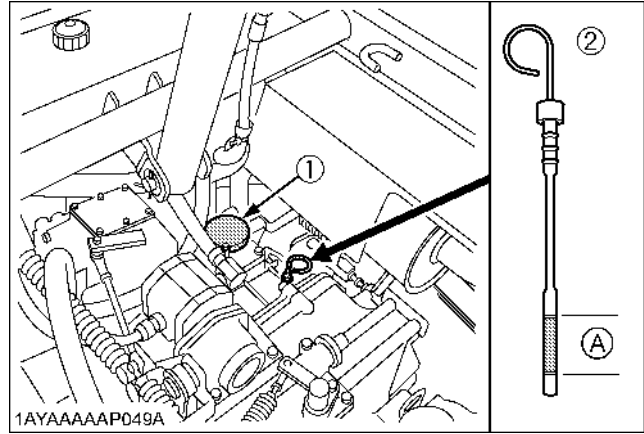

(1) Oil inlet (A) Oil level is acceptable within this range
(2) Dipstick

IMPORTANT :

- To prevent serious damage to the transmission, use only a KUBOTA genuine filter.

■ Replacing Transmission Oil Filter [SUCTION]



CAUTION

To avoid personal injury:

- Be sure to stop the engine before changing the oil filter.
- Allow engine to cool down sufficiently, oil can be hot and can burn.

1. Park the vehicle on a flat surface, raise the cargo bed and mount the safety support.
2. Disconnect the number plate lamp harness. Disconnect the trailer electrical outlet harness.
3. Remove the number plate and hose guard.
4. Remove the oil filters.
5. Put a film of clean transmission oil on the rubber seal of the new filter.
6. Quickly tighten the filter until it contacts the mounting surface, then, with a filter wrench, tighten it an additional 1 turn only.
7. After the new filter has been replaced, fill the transmission oil up to the upper notch on the dipstick.
8. After running the engine for a few minutes, stop the engine and check the oil level again, add oil to the prescribed level.
9. Make sure that the transmission fluid doesn't leak past the seal on the filters.
10. Install the number plate and hose guard.
11. Connect the number plate lamp harness. Connect the trailer electrical outlet harness.

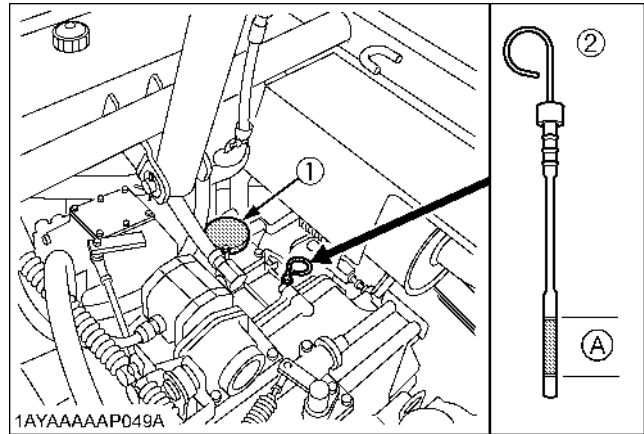

(1) Oil inlet (A) Oil level is acceptable within this range
 (2) Dipstick

IMPORTANT :

- To prevent serious damage to the transmission, use only a KUBOTA genuine filter.

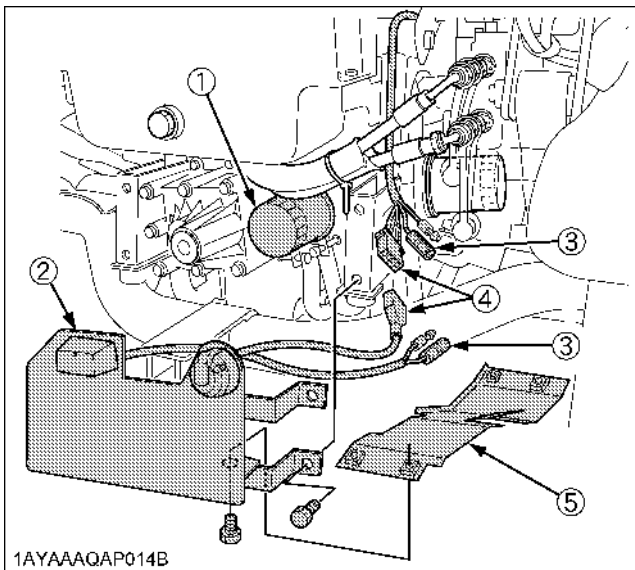

(1) Transmission oil filter (Suction) (Orange color)
 (2) Number plate
 (3) Number plate lamp harness
 (4) Trailer electrical outlet harness
 (5) Hose guard

■ Changing Hydraulic Lift Oil



CAUTION

To avoid personal injury:

- Be sure to stop the engine before changing the oil.
- Allow engine to cool down sufficiently, oil can be hot and can burn.

1. Park the vehicle on a firm, flat and level surface.
2. Raise the cargo bed and mount the safety support. (See "HOW TO RAISE THE CARGO BED" in "PERIODIC SERVICE" section.)
3. To drain the used oil, remove the drain plug and filling plug and drain the oil completely into the oil pan.
4. After draining, reinstall the drain plug.
5. Fill with new KUBOTA SUPER UDT fluid up to the upper notch on the dipstick. (See "LUBRICANTS, FUEL AND COOLANT" in "MAINTENANCE" section.)

How to check:

Wipe dipstick clean with a rag and screw it into filling hole. Remove dipstick again to see if the oil level is between the upper and lower notch.

6. After filling, reinstall the filling plug.

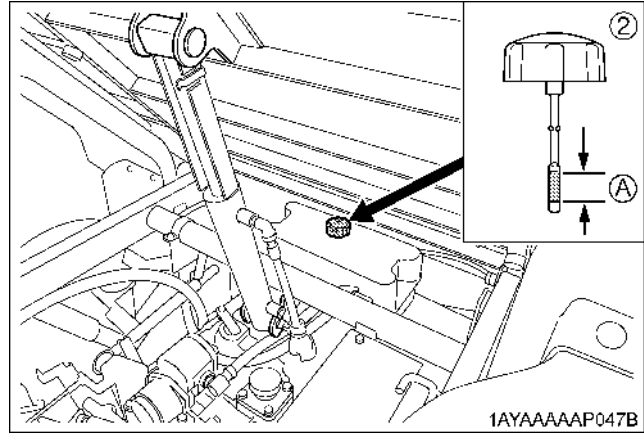

(1) Drain plug

(2) Filling plug with dipstick

(A) Oil level is acceptable within this range

Oil Capacity	8 L
--------------	-----

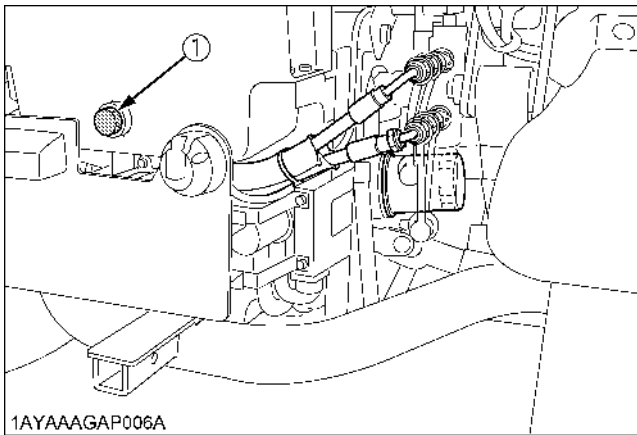

1AYAAAGAP006A

■ Checking Brake Pedal

CAUTION

To avoid personal injury:

- Stop the engine and chock the wheels before checking brake pedal.
- If movement is outside of the specifications, contact your local KUBOTA Dealer for adjusting the brake.

◆ Checking the brake pedal free travel

Proper brake pedal free travel	7 to 14 mm on the pedal
--------------------------------	-------------------------

1. Release the parking brake.
2. Slightly depress the brake pedal and measure free travel at the top of the pedal stroke.
3. If brake pedal free travel is outside of the specifications, contact your local KUBOTA Dealer for adjusting the brake.

◆ Checking the brake pedal stroke

Pedal stroke	Less than 120 mm on the pedal
--------------	-------------------------------

1. Release the parking brake.
2. Step on the pedal and measure the pedal stroke.
3. If brake pedal stroke is outside of the specifications, contact your local KUBOTA Dealer for adjusting the brake.

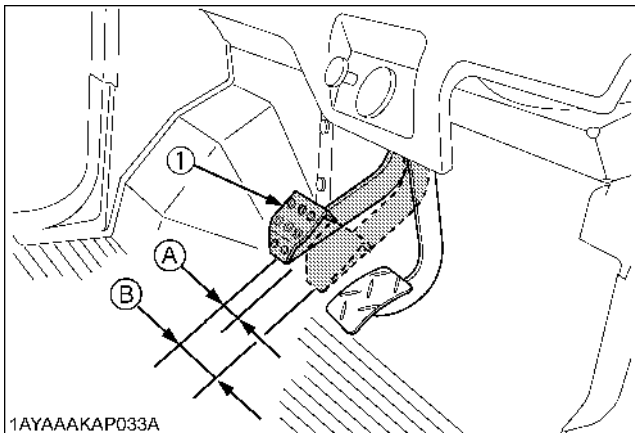

(1) Brake pedal

(A) "FREE TRAVEL"
(B) "PEDAL STROKE"

■ Checking Brake Hose and Pipe

1. Check to see that brake hose and pipe are not swollen, hardened or cracked.
2. Check the brake hose and pipe joints for oil leaks.
3. If there is any abnormality, consult your local KUBOTA Dealer for this service.

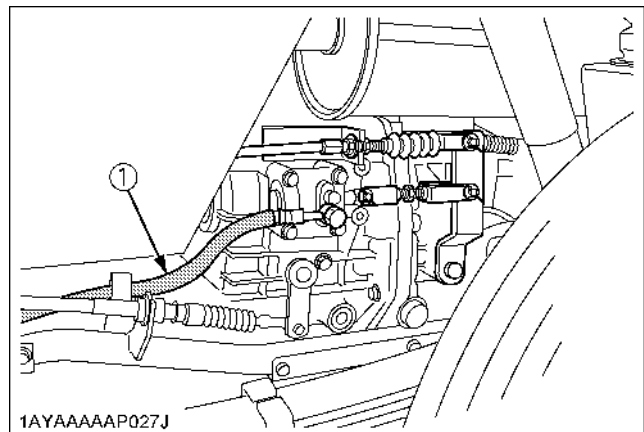
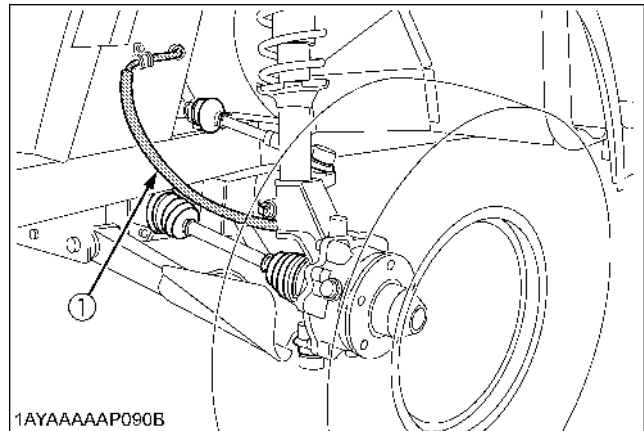

(1) Brake hose

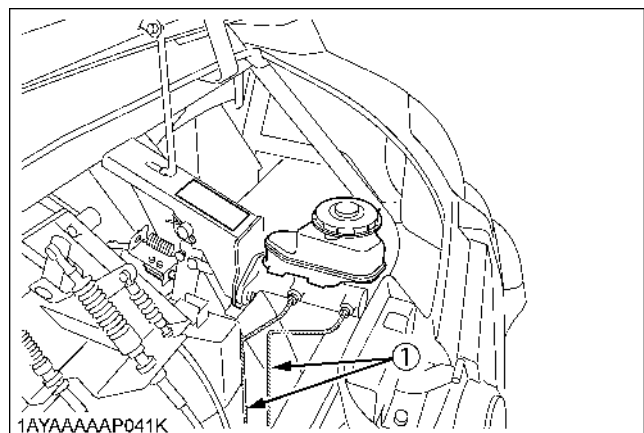

(1) Brake pipe

■ Checking Front Brake Case

1. Remove the drain plug.
2. Check the brake case for brake fluid leak.
3. If there is brake fluid leak, consult your local KUBOTA Dealer for this service.

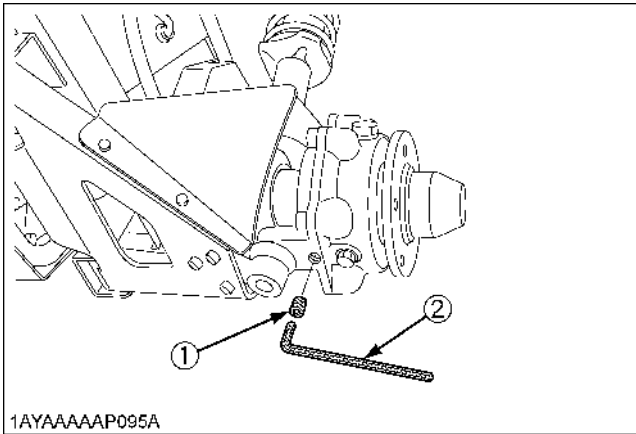
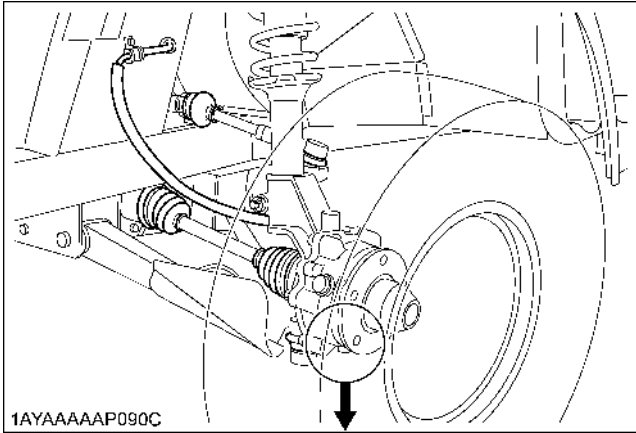

- (1) Drain plug
(2) Allen key

■ Checking Brake Light Switch

1. Park the vehicle on a flat surface and raise the cargo bed.
2. Turn the key switch to the "ON" position.
3. Step on the brake pedal to check if the brake light comes on.
4. If it does not, check the bulb or brake light switch.

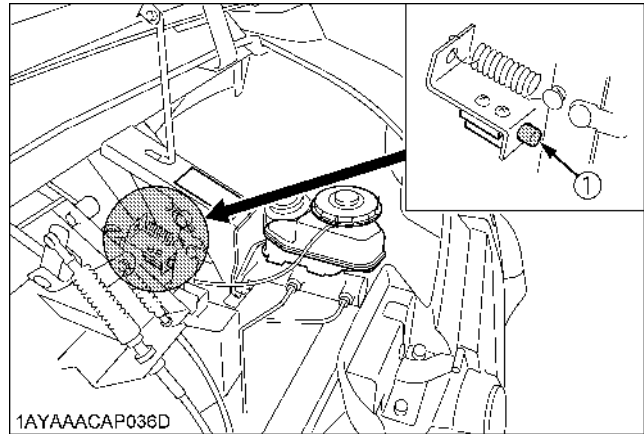

(1) Brake light switch

■ Checking Radiator Hose and Clamp

Park the vehicle on a flat surface and raise the cargo bed. Check to see if radiator hoses are properly fixed every 200 hours of operation or six months, whichever comes first.

1. If hose clamps are loose or water leaks, tighten bands securely.
 2. Replace hoses and tighten hose clamps securely, if radiator hoses are swollen, hardened or cracked.
- Replace hoses and hose clamps every 2 years or earlier if checked and found that hoses are swollen, hardened or cracked.

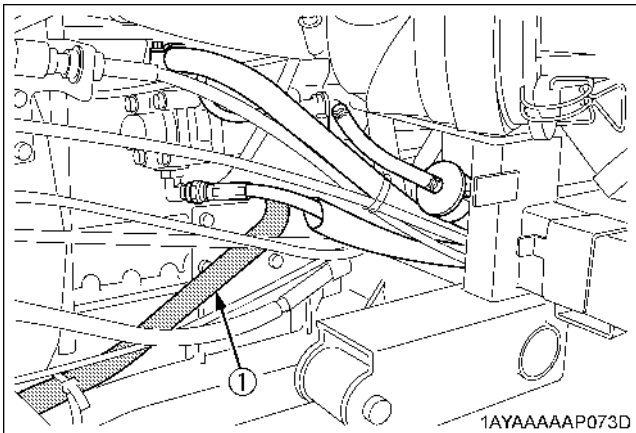
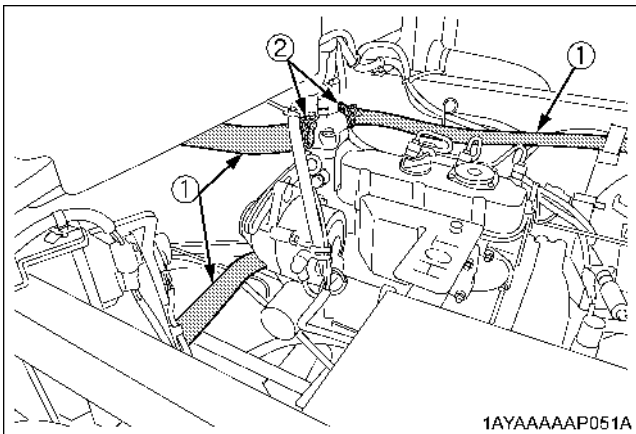

(1) Radiator hoses
(2) Clamp bands

◆ Precaution at Overheating

Take the following actions in the event the coolant temperature is close to or more than the boiling point, which is called "Overheating".

1. Stop the vehicle operation in a safe place and keep the engine unloaded idling.
2. Don't stop the engine suddenly, but stop it after about 5 minutes of unloaded idling.
3. Keep yourself well away from the vehicle for at least 10 minutes or while the steam is blowing out.
4. Check to see if there is no danger such as burning, get rid of the causes of overheating according to the "TROUBLESHOOTING" section of this manual, and then start the engine again.

■ Checking Power Steering Line

1. Check to see that all lines and hose clamps are tight and not damaged.
2. If hoses and clamps are found worn or damaged, replace or repair them at once.

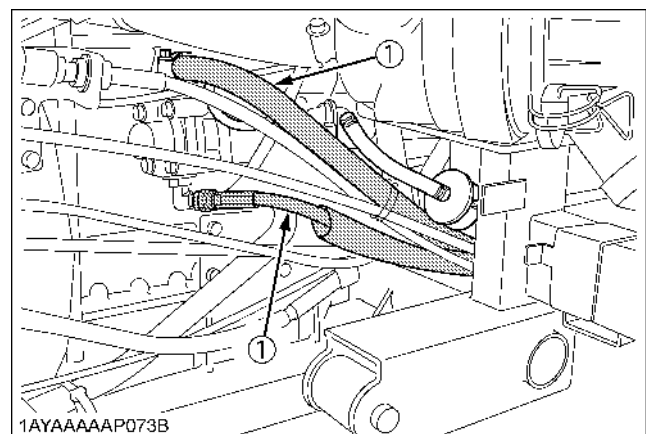
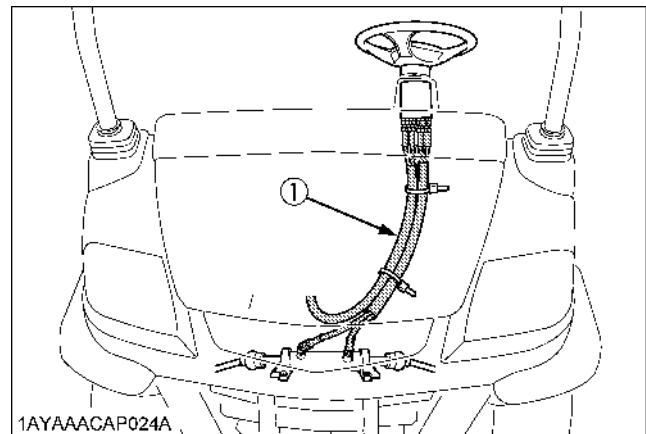

(1) Power steering pressure hoses

■ Changing Power Steering Oil

CAUTION

To avoid personal injury:

- Be sure to stop the engine before changing the oil.
- Allow engine to cool down sufficiently, oil can be hot and can burn.

1. Park the vehicle on a flat surface and raise the cargo bed.
2. To drain the used oil, remove the suction hose on the gear pump.
3. Drain the oil completely into the oil pan.
4. After draining, reinstall suction hose.
5. Fill with the new oil up to the "H" mark of the oil tank. (See "LUBRICANTS, FUEL AND COOLANT" in "MAINTENANCE" section.)
6. Start the engine and then turn the steering wheel toward the right and left several times (this motion causes air in the hose to discharge).
7. Check to see if the oil level is between the "H" and "L" marks on the oil tank.

Oil capacity	5.9 L
--------------	-------

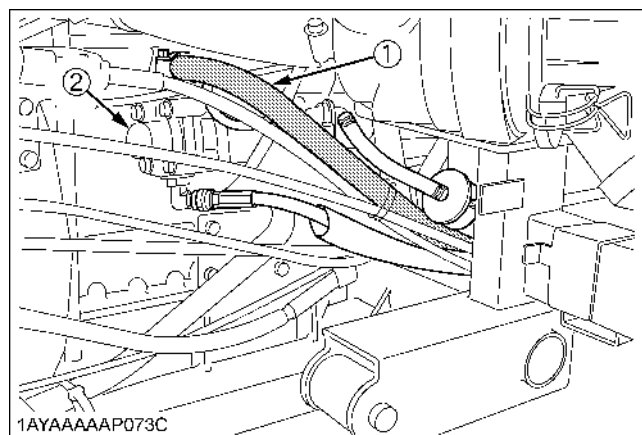

(1) Suction hose
(2) Gear pump

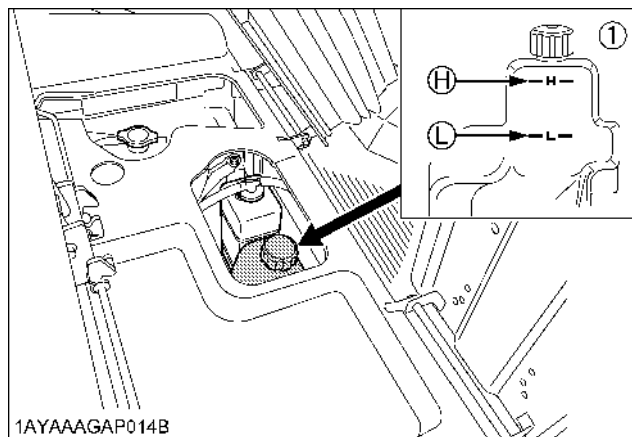

(1) Power steering oil tank (H) "HIGH"
(L) "LOW"

■ Checking Intake Air Line

1. Check to see if the hoses and hose clamps are tight and not damaged.
2. If hoses and clamps are found to be worn or damaged, replace or repair them at once.

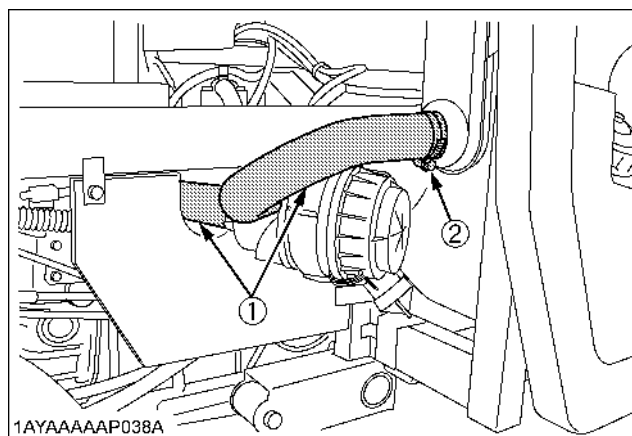

(1) Hose
(2) Hose clamps

EVERY 300 HOURS

■ Checking Tire

1. Check to see if tires are not damaged.
2. If the tires are cracked, bulged, or cut, or they are worn out, replace or repair them at once.

◆ Tire Tread Depth

Always replace the tires when the tread depth is worn to minimum allowable.

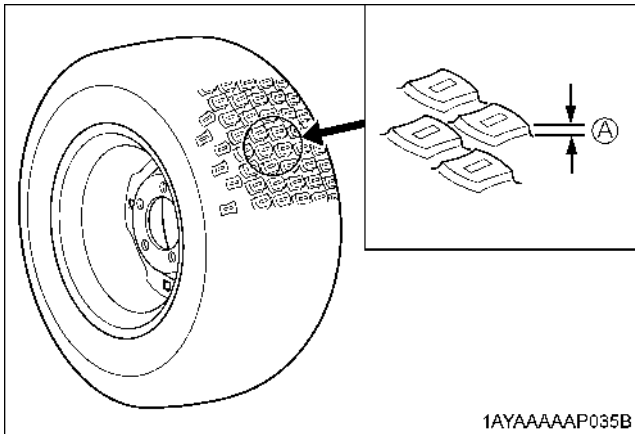

1AYAAAAAP035B

(A) 3 mm

EVERY 400 HOURS

■ Changing Knuckle Case Oil

1. Remove the tire.
2. Park the vehicle on a firm, flat and level surface.
3. To drain the used oil, remove the drain and filling plugs at the LH knuckle case and drain the oil completely into the oil pan.
4. After draining, reinstall the drain plug.
5. Fill with the new oil up to the filling port level. (See "LUBRICANTS, FUEL AND COOLANT" in "MAINTENANCE" section.)
6. After filling, reinstall the filling plug.
7. Use the same procedure to change the RH knuckle case oil.

Oil capacity (one side)	Ref. 0.15 L
-------------------------	-------------

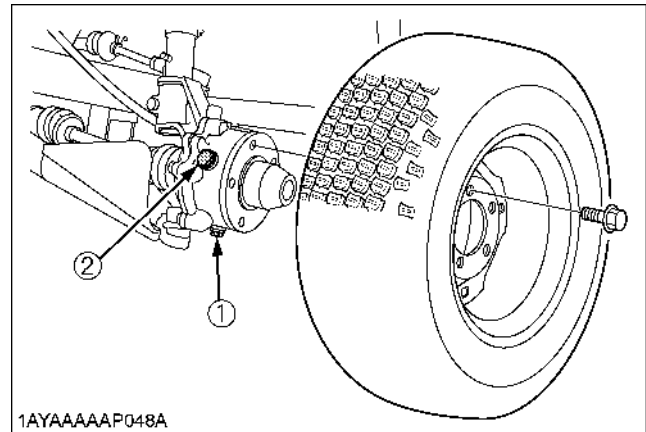

1AYAAAAAP048A

- (1) Drain plug
- (2) Filling plug

■ Changing Transmission Fluid



CAUTION

To avoid personal injury:

- Be sure to stop the engine before changing the oil.
- Allow engine to cool down sufficiently, oil can be hot and can burn.

1. Park the vehicle on a flat surface, raise the cargo bed, and mount the safety support.
2. To drain the used oil, remove the drain plug at the bottom of the transmission case and drain the oil completely into the oil pan.
3. Clean off metal filings with clean rags at the drain plug with magnet.
4. After draining, reinstall the drain plug.
5. Fill with the new KUBOTA SUPER UDT fluid up to the upper notch on the dipstick.
(See "LUBRICANTS, FUEL AND COOLANT" in "MAINTENANCE" section.)
6. After running the engine for a few minutes, stop the engine and check the oil level again; add oil to prescribed level.

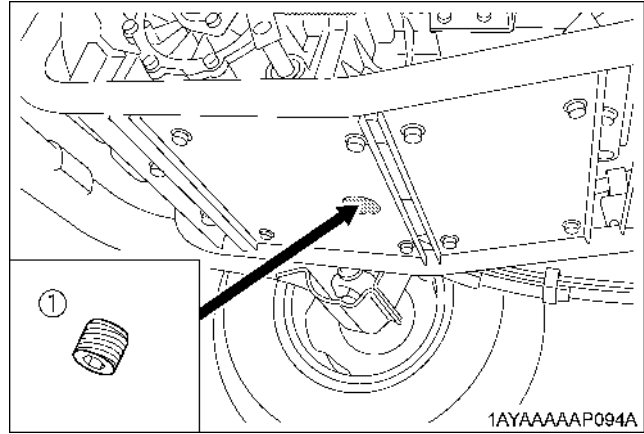

(1) Drain plug with magnet

◆ **Cleaning magnetic plug**

Remove the magnetic plug and clean off metal filings.

IMPORTANT :

- Do not operate the vehicle immediately after changing the transmission fluid.
Run the engine at medium speed for a few minutes to prevent damage to the transmission.

Oil Capacity	10 L
--------------	------

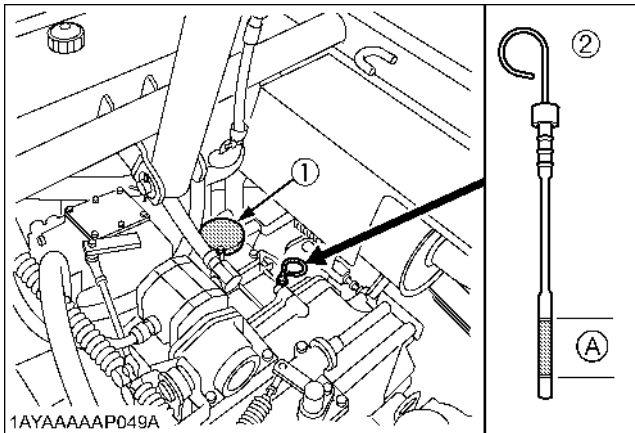

(1) Oil inlet
(2) Dipstick

(A) Oil level is acceptable within this range

Changing Front Axle Case Oil

1. Park the vehicle on a firm, flat and level surface.
2. To drain the used oil, remove the drain and filling plugs at the front axle case and drain the oil completely into the oil pan.
3. After draining, reinstall the drain plug.
4. Fill with the new oil up to the upper notch on the dipstick.
(See "LUBRICANTS, FUEL AND COOLANT" in "MAINTENANCE" section.)
5. After filling, reinstall the filling plug.

Oil capacity	0.6 L
--------------	-------

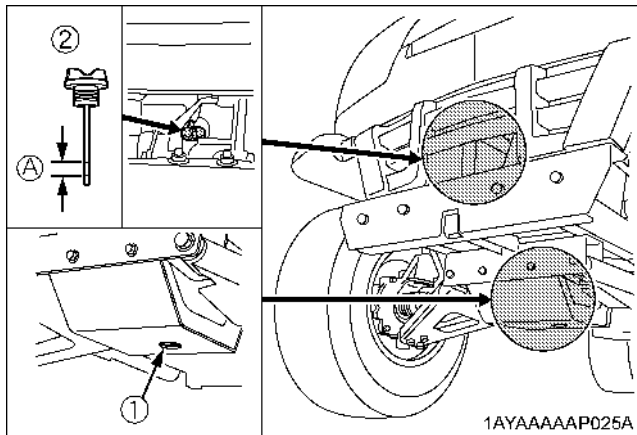

(1) Drain plug
(2) Filling plug with dipstick

(A) Oil level is acceptable within this range

EVERY 500 HOURS

Replacing Fuel Filter

Consult your local KUBOTA Dealer for this service.

EVERY 800 HOURS

Adjusting Engine Valve Clearance

Consult your local KUBOTA Dealer for this service.

EVERY 1500 HOURS

Checking Fuel Injection Nozzle Injection Pressure

Consult your local KUBOTA Dealer for this service.

EVERY 3000 HOURS

Checking Injection Pump

Consult your local KUBOTA Dealer for this service.

EVERY 1 YEAR

Replacing Air Cleaner Primary Element and Secondary Element

(See "Cleaning Air Cleaner Primary Element" in "EVERY 100 HOURS" in "PERIODIC SERVICE" section.)

EVERY 2 YEARS

■ Changing Brake Fluid

Consult your local KUBOTA Dealer for this service.
(See "Checking Brake Fluid Level" in "DAILY CHECK" in "PERIODIC SERVICE" section.)

■ Flush Cooling System and Changing Coolant



CAUTION

To avoid personal injury:

- Do not remove the radiator cap while coolant is hot. When cool, slowly rotate cap to the first stop and allow sufficient time for excess pressure to escape before removing the cap completely.

1. Stop the engine and let cool down.
2. Remove the protective cover.
3. To drain the coolant, open the radiator drain plug and remove radiator cap. The radiator cap must be removed to completely drain the coolant.
4. After all coolant is drained, close the drain plug.
5. Fill with clean water and cooling system cleaner.
6. Follow directions of the cleaner instruction.
7. After flushing, fill with clean water and anti-freeze until the coolant level is just below the radiator cap. Install the radiator cap securely.
8. Fill with fresh water up to the "FULL" mark on the recovery tank.
9. Start and operate the engine for few minutes.
10. Stop the engine and let cool.
11. Check coolant level of recovery tank and add coolant if necessary.

Coolant capacity	4.0 L
------------------	-------

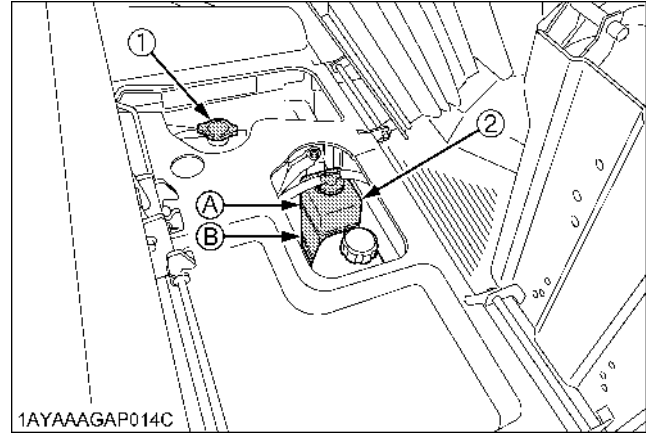

- (1) Radiator cap
(2) Recovery tank
(A) "FULL"
(B) "LOW"

IMPORTANT :

- Do not start engine without coolant.
- Use clean, fresh water and anti-freeze to fill the radiator and recovery tank.
- When the anti-freeze is mixed with water, the antifreeze mixing ratio must be less than 50%.
- Securely tighten radiator cap. If the cap is loose or improperly fitted, water may leak out and the engine could overheat.

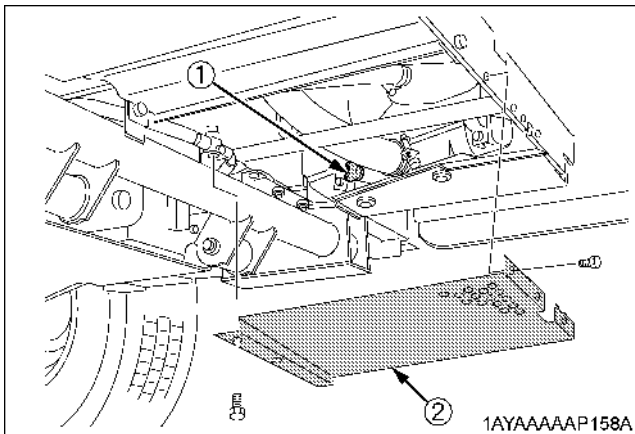

- (1) Drain plug
(2) Protective cover

■ Anti-Freeze



CAUTION

To avoid personal injury:

- When using antifreeze, put on some protection such as rubber gloves. (Antifreeze contains poison.)
- If should drink antifreeze, throw up at once and take medical attention.
- When antifreeze comes in contact with the skin or clothing, wash it off immediately.
- Do not mix different types of Antifreeze. The mixture can produce chemical reaction causing harmful substances.
- Antifreeze is extremely flammable and explosive under certain conditions. Keep fire and children away from antifreeze.
- When draining fluids from the engine, place some container underneath the engine body.
- Do not pour waste onto the grounds, down a drain, or into any water source.
- Also, observe the relevant environmental protection regulations when disposing of antifreeze.

If it freezes, coolant can damage the cylinders and radiator. If the ambient temperature falls below 0 °C or before a long-term storage, let out cooling water completely, or mix fresh water with long-life coolant and fill the radiator and recovery tank with the mixture.

1. Long-life coolant (hereafter LLC) comes in several types. Use ethylene glycol (EG) type for this engine.
2. Before employing LLC-mixed cooling water, fill the radiator with fresh water and empty it again. Repeat this procedure 2 or 3 times to clean up the inside.
3. Mixing the LLC
Put the LLC in cooling water in the percentage (%) for a target temperature. When mixing, stir it up well, and then fill into the radiator.
4. The procedure for the mixing of water and antifreeze differs according to the make of the antifreeze and the ambient temperature. Refer to SAE J1034 standard, more specifically also to SAE J814c.

IMPORTANT :

- When the antifreeze is mixed with water, the antifreeze mixing ratio must be less than 50%.

Vol % Anti-freeze	Freezing Point °C	Boiling Point* °C
40	-24	106
50	-37	108

* At 1.013 x 10⁵Pa (760 mmHg) pressure (atmospheric).

A higher boiling point is obtained by using a radiator pressure cap which permits the development of pressure within the cooling system.

5. Adding the LLC
 - (1) Add only water if the mixture reduces in amount by evaporation.
 - (2) If there is a mixture leak, add the LLC of the same manufacturer and type in the same mixture percentage.
 - * Never add any long-life coolant of different manufacturer. (Different brands may have different additive components, and the engine may fail to perform as specified.)
6. When the LLC is mixed, do not employ any radiator cleaning agent. The LLC contains anticorrosive agent. If mixed with the cleaning agent, sludge may build up, adversely affecting the engine parts.
7. Kubota's genuine long-life coolant has a service life of 2 years. Be sure to change the coolant every 2 years.

NOTE :

- The above data represent industry standards that necessitate a minimum glycol content in the concentrated antifreeze.
- When the coolant level drops due to evaporation, add water only to keep the antifreeze mixing ratio less than 50%. In case of leakage, add antifreeze and water in the specified mixing ratio before filling into the radiator.

■ Replacing Radiator Hose (Water pipes)

Replace the hoses and clamps.

(See "Checking Radiator Hose and Clamp" in "EVERY 200 HOURS" in "PERIODIC SERVICE" section.)

■ Replacing Power Steering Hose

Consult your local KUBOTA Dealer for this service.

■ Replacing Fuel Hose

Consult your local KUBOTA Dealer for this service.

■ Replacing Brake Master Cylinder (Inner Parts)

Consult your local KUBOTA Dealer for this service.

■ Replacing Front Brake Seal

Consult your local KUBOTA Dealer for this service.

■ Replacing Rear Brake Cylinder Seal

Consult your local KUBOTA Dealer for this service.

■ Replacing Intake Air Line

Consult your local KUBOTA Dealer for this service.

■ Replacing Remote Hydraulic Hose

Consult your local KUBOTA Dealer for this service.

EVERY 4 YEARS**■ Replacing Brake Hose**

Consult your local KUBOTA Dealer for this service.

SERVICE AS REQUIRED**■ Bleeding Fuel System**

Air must be removed:

1. When the fuel filter or lines are removed.
2. When tank is completely empty.
3. After the vehicle has not been used for a long period of time.

◆ Bleeding procedure is as follows:

1. Fill the fuel tank with fuel.
2. Start the engine and run for about 30 seconds, and then stop the engine.

■ Replacing Fuse

The vehicle electrical system is protected from potential damage by fuses.

A blown fuse indicates that there is an overload or short somewhere in the electrical system.

If any of the fuses should blow, replace with a new one of the same capacity.

IMPORTANT :

- Before replacing a blown fuse, determine why the fuse blew and make any necessary repairs. Failure to follow this procedure may result in serious damage to the vehicle electrical system. Consult your local KUBOTA Dealer for specific information dealing with electrical problems.

◆ Replacement procedure

1. Disconnect the negative cable of the battery.
2. Remove the cover and the fuse box cover.
3. Pull out the blown fuse using FUSE PULLER in the fuse box.
4. Insert a new fuse into the fuse box.
5. Install the fuse box cover and the cover.
6. Connect the negative battery cable.

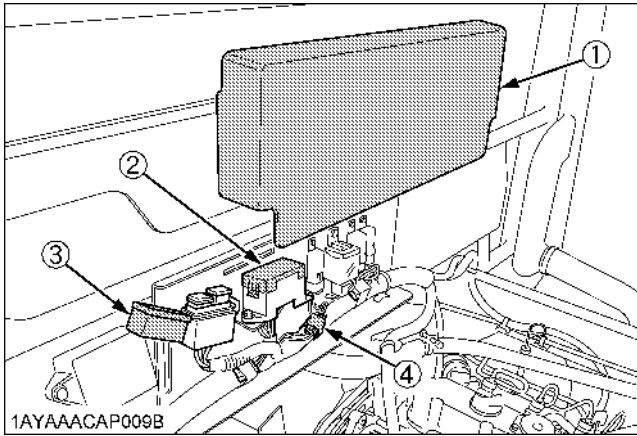

- (1) Cover
- (2) Fuse box cover
- (3) Slow-blow fuse box cover
- (4) Glow lamp fuse

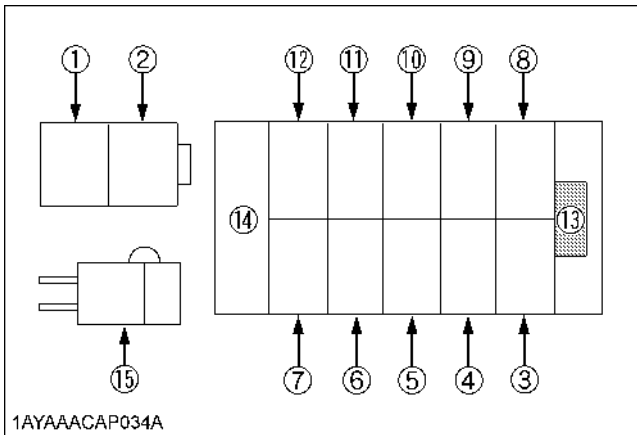

◆ Protected circuit

Fuse No.	Capacity (A)	Protected circuit
1	Slow-blow fuse (50)	Key switch
2	Slow-blow fuse (60)	Alternator
3	10	Eng. stop control Panel (Beacon light)
4	15	Hazard
5	15	Head lamp Horn Position lamp
6	20	Fan motor
7	15	Eng. Stop
8	10	Alternator Fan motor relay (Speedometer)
9	10	Hazard
10	10	Brake lamp Panel (Beeper)
11	10	12V DC output
12	15	(Work light)
13	---	Fuse puller
14	5, 10, 15, 20	Spare
15	5	Glow lamp

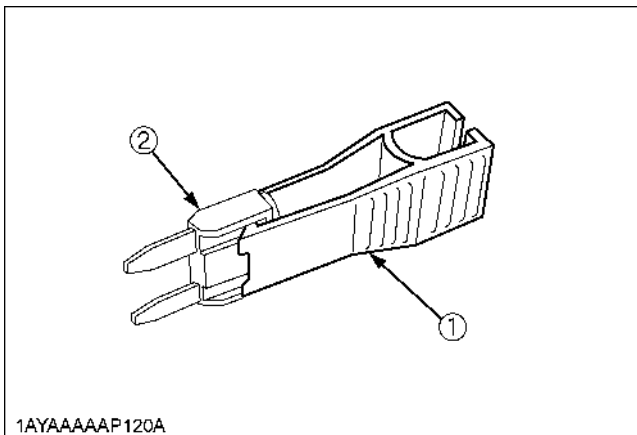

- (1) Fuse puller
- (2) Fuse

■ Replacing Slow-Blow Fuses

The slow-blow fuses are intended to protect the electrical cabling. If any of them have blown out, be sure to pinpoint the cause. Never use any substitute, use only a KUBOTA genuine part.

◆ Replacement procedure

1. Disconnect the negative cable of the battery.
2. Remove the cover and the slow-blow fuse box cover.
3. Pull out the slow-blow fuse.
4. Insert a new slow-blow fuse into the slow-blow fuse box.
5. Install the slow-blow fuse box cover and the cover.
6. Connect the negative battery cable.

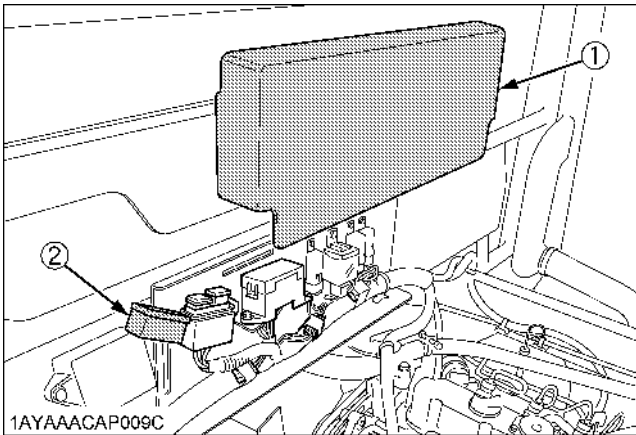

- (1) Cover
(2) Slow-blow fuse box cover

■ Replacing Light Bulb

1. Head lights
Take the bulb out of the light body and replace it with a new one.
2. Other lights
Detach the lens and replace the bulb.

Light	Capacity
Head lights	40 W / 45 W
Turn signal / Hazard light	21 W
Front position light	5 W
Stop light / Tail light	21 W / 10 W
Number plate light	10 W
Easy Checker(TM)	3.8 W (14V, 0.27A)
Instrument panel light	3.8 W (14V, 0.27A)

STORAGE



CAUTION

To avoid personal injury:

- Do not clean the vehicle with engine running.
- To avoid the danger of exhaust fume poisoning, do not operate the engine in a closed building without proper ventilation.
- When storing, remove the key from the key switch to avoid unauthorized persons from operating the vehicle and getting injured.

VEHICLE STORAGE

If you intend to store your vehicle for an extended period of time, follow the procedures outlined below.

These procedures will insure that the vehicle is ready to operate with minimum preparation when it is removed from storage.

1. Check the bolts and nuts for looseness, and tighten if necessary.
2. Apply grease to vehicle areas where bare metal will rust also to pivot areas.
3. Unload from cargo bed.
4. Inflate the tires to a pressure a little higher than usual.
5. Change the engine oil and run the engine to circulate oil throughout the engine block and internal moving parts for about five minutes.
6. Coat any exposed hydraulic cylinder piston rods with grease.
7. Remove the battery from the vehicle. Store the battery following the battery storage procedures.
(See "Checking Battery Condition" in "EVERY 100 HOURS" in "PERIODIC SERVICE" section.)
8. Keep the vehicle in a dry place where the vehicle is sheltered from the elements. Cover the vehicle.
9. Store the vehicle indoors in a dry area that is protected from sunlight and excessive heat. If the vehicle must be stored outdoors, cover it with a waterproof tarpaulin.
Put boards under the tires to keep dampness away from tire.
Keep the tires out of direct sunlight and extreme heat.

IMPORTANT :

- When washing the vehicle, be sure to stop the engine. Allow sufficient time for the engine to cool before washing.
- Do not wash with a high-pressure car-washing machine.
- Cover the vehicle after the muffler and the engine have cooled down.

REMOVING THE VEHICLE FROM STORAGE

1. Check the tire air pressure and inflate the tires if they are low.
2. Install the battery. Before installing the battery, be sure it is fully charged.
3. Check the alternator belt tension.
4. Check all fluid levels (engine oil, transmission oil, engine coolant and any attached implements).
5. Start the engine. Observe all gauges. If all gauges are functioning properly and reading normal, move the vehicle outside. Once outside, park the vehicle and let the engine idle for at least five minutes. Shut the engine off and walk around vehicle and make a visual inspection looking for evidence of oil or water leaks.
6. With the engine fully warmed up, release the parking brake and test the brakes for proper adjustment as you move forward. Adjust the brakes as necessary.

TROUBLESHOOTING

ENGINE TROUBLESHOOTING

If something is wrong with the engine, refer to the table below for the cause and its corrective measure.

Trouble		Cause	Countermeasure
Engine is difficult to start or won't start.		<ul style="list-style-type: none"> No fuel flow. 	<ul style="list-style-type: none"> Check the fuel tank and the fuel filter. Replace filter if necessary.
		<ul style="list-style-type: none"> Air or water is in the fuel system. 	<ul style="list-style-type: none"> Check to see if the fuel line coupler bolt and nut are tight. Bleed the fuel system. (See "Bleeding Fuel System" in "SERVICE AS REQUIRED" in "PERIODIC SERVICE" section.)
		<ul style="list-style-type: none"> In winter, oil viscosity increases, and engine revolution is slow. 	<ul style="list-style-type: none"> Use oils of different viscosities, depending on ambient temperatures.
		<ul style="list-style-type: none"> Battery becomes weak and the engine does not turn over quick enough. 	<ul style="list-style-type: none"> Clean battery cables and terminals. Charge the battery. In cold weather, always remove the battery from the engine, charge and store it indoors. Install it on the vehicle only when the vehicle is going to be used.
Insufficient engine power.		<ul style="list-style-type: none"> Insufficient or dirty fuel. The air cleaner is clogged. 	<ul style="list-style-type: none"> Check the fuel system. Clean or replace the element.
Engine stops suddenly.		<ul style="list-style-type: none"> Insufficient fuel. 	<ul style="list-style-type: none"> Refuel. Bleed the fuel system if necessary.
Exhaust fumes are colored.	Black	<ul style="list-style-type: none"> Fuel quality is poor. Too much oil. The air cleaner is clogged. 	<ul style="list-style-type: none"> Change the fuel and fuel filter. Check the proper amount of oil. Clean or replace the element.
	Blue white	<ul style="list-style-type: none"> The inside of exhaust muffler is dumped with fuel. Injection nozzle trouble. Fuel quality is poor. 	<ul style="list-style-type: none"> Heat the muffler by applying load to the engine. Check the injection nozzle. Change the fuel and fuel filter.
Engine overheats		<ul style="list-style-type: none"> Engine overloaded. 	<ul style="list-style-type: none"> Shift to lower gear or reduce load.
		<ul style="list-style-type: none"> Low coolant level. 	<ul style="list-style-type: none"> Fill cooling system to the correct level; check radiator and hoses for loose connections or leaks.
		<ul style="list-style-type: none"> The motor driven fan does not turn. 	<ul style="list-style-type: none"> Check to see if the fuse is not blown. Check the electric system.
		<ul style="list-style-type: none"> Dirty radiator core or grille screens. 	<ul style="list-style-type: none"> Remove all trash.
		<ul style="list-style-type: none"> Coolant flow route corroded. 	<ul style="list-style-type: none"> Flush cooling system.

If you have any questions, contact your local KUBOTA Dealer.

BATTERY TROUBLESHOOTING

Trouble	Cause	Countermeasure	Preventive measure
Starter does not function.	● Battery overused until lights are dim.	● Charge battery sufficiently.	● Charge the battery properly.
	● Battery has not been recharged.		
	● Poor terminal connection.	● Clean the terminal and tighten securely.	● Keep the terminal clean and tight. Apply grease and treat with anti-corrosives.
	● Battery life expired.	● Renew battery.	
From beginning starter does not function, and lights soon become dim.	● Insufficient charging.	● Charge battery sufficiently.	● Battery must be serviced properly before initial use.
When viewed from top, the top of plates look whitish. * Refillable type battery only	● Battery was used with an insufficient amount of electrolyte.	● Add distilled water and charge the battery.	● Regularly check the electrolyte level.
	● Battery was used too much without recharging.	● Charge battery sufficiently.	● Charge the battery properly.
Recharging is impossible.	● Battery life expired.	● Replace battery.	
Terminals are severely corroded and heat up.	● Poor terminal connection.	● Clean the terminal and tighten securely.	● Keep the terminal clean and tight. Apply grease and treat with anti-corrosives.
Battery electrolyte level drops rapidly. * Refillable type battery only	● There is a crack or pin holes in the electrolytic cells.	● Replace battery.	
	● Charging system trouble.	● Consult your local KUBOTA Dealer.	

- If you have any questions, consult your local KUBOTA Dealer.
- The factory-installed battery is non-refillable type.

MACHINE TROUBLESHOOTING

Trouble	Cause	Countermeasure
Machine operation is not smooth.	● Hydrostatic transmission fluid is insufficient.	● Replenish oil.
	● Filter is clogged.	● Replace the filter.
Machine does not move while engine is running.	● Parking brake is on.	● Release the parking brake.
	● Transmission fluid level is insufficient.	● Replenish oil.
Brakes not working correctly	● Brake fluid level is low.	● Check fluid level.
	● Air is in brake system.	● Consult your KUBOTA Dealer.
	● Brake pads are worn.	● Consult your KUBOTA Dealer.
Brake noise	---	● Consult your KUBOTA Dealer.

If you have any questions, consult your local KUBOTA Dealer.

KUBOTA Corporation is ...

Since its inception in 1890, KUBOTA Corporation has grown to rank as one of the major firms in Japan.

To achieve this status, the company has through the years diversified the range of its products and services to a remarkable extent, until today, 19 plants and 16,000 employees produce over 1,000 different items, large and small.

All these products and all the services which accompany them, however, are unified by one central commitment. KUBOTA makes products which, taken on a national scale, are basic necessities. Products which are indispensable, products intended to help individuals and nations fulfill the potential inherent in their environment. For KUBOTA is the Basic Necessities Giant.

This potential includes water supply, food from the soil and from the sea, industrial development, architecture and construction, transportation.

Thousands of people depend on KUBOTA's know-how, technology, experience and customer service. You too can depend on KUBOTA.