



# Operator Manual and Parts List

**MAJOR**  
**FINISHING MOWERS**  
MR150, MR180 and MR235



**Head Office**

Major Equipment Intl Ltd  
Ballyhaunis,  
Co. Mayo,  
Ireland

Tel.: 09496 30572  
Fax: 09496 30788

**UK Office**

Major Equipment Ltd.  
Major Industrial Estate.  
Middleton Rd  
Heysham  
Lancs.  
LA3 3JJ

Tel.: 01524 850 501  
Fax: 01524 850 502

**NL & GERMANY OFFICE**

Major Equipment Intl Ltd  
Postbus 29  
NL-7700 AA  
Dedemsvaart  
Nederland

Tel: + 31 (0) 6389 19585

Web: [www.major-equipment.com](http://www.major-equipment.com)

We suggest that you record your machine details along with your dealers address & telephone number for your convenience

MODEL: \_\_\_\_\_ SERIAL NO: \_\_\_\_\_

DEALER: \_\_\_\_\_

ADDRESS: \_\_\_\_\_

\_\_\_\_\_

\_\_\_\_\_

TEL NO: \_\_\_\_\_

**Disclaimer**

While every effort has been made in the production of this manual to ensure that the information contained herein is full and correct, Major assumes no responsibility for errors or omissions.

Major reserves the right to modify the machinery and the technical data contained within the manual without prior notice.

Further to this, Major assumes no liability for any damages which may result from the use of the information contained within this manual.

# Contents

## **Introduction**

Identification Data	2
Main Parts	2

## **Safety Regulations**

General Safety regulations	3
Regulations for use of the driveline	3
Starting regulations	4
Warning and danger plates and stickers	5
Key to safety devices	6
Delivery of the mower	7

## **Hitching to the tractor**

Preliminary instructions on use of the machine	8
Coupling the machine to the tractor	11
Shortening the driveline	12

## **Use of the Machine**

Preparing the implement for work	13
Use of the machine	14
Demounting the implement from the tractor	15

## **Maintenance**

Technician specifications	15
Inspections before use	16
Periodical inspections	16
Storage of machine	19

## **Spare Parts**

Spare parts list	20
Trouble shooting	28
Warranty procedure	30

## **EEC certificate of conformity for machines**

*(conforming to Directive 98/37/EEC)*

Company: Major Equipment Ltd.  
Address: Coolnaha,  
Ballyhaunis,  
Co. Mayo,  
Ireland.  
Tel. +353949630572  
Fax +353949630788

*declares in sole responsibility that the product:*

### **FINISHING MOWER**

When properly installed, maintained and used only for it's intended purpose, complies with all the essential Health & Safety requirements of:

- **THE SUPPLY OF MACHINERY (SAFETY) REGULATIONS 2008.**
- **S.I. No. 299 of 2007**, Safety, Health and Welfare at Work (General Application) Regulations 2007 (Ireland).
- **Health & Safety at Work, etc. Act 1974 (c.37) (UK).**
- **EN ISO 12100:2010, ISO 11684:1995.**
- **EN ISO 13857:2009, EN 349:2009, EN ISO 4413:2011.**
- **EN ISO 4254-12:2012, EN ISO 4254-1:2010**

I certify on behalf of Major Equipment Int. Ltd., that this machine when properly installed and operated correctly, complies with all the essential Health & Safety requirements of all legislation referred to above.

Signature :   
Managing Director

Date 11/01/2013

## **INTRODUCTION**

Thank you for purchasing this Major Finishing Mower. Please carefully read this operation manual and strictly observe these instructions for the safety of you and the personnel around you. In this manner, you will enjoy long and satisfactory use of this product.

The user of the mower (also called "Implement" or "Machine" in the text) is personally responsible for his own safety and that of any other people in the vicinity of the machine.

It is therefore essential for the user to possess detailed knowledge about how to use, service and correctly mount the mower on the tractor. The machine's user must be an operator with a suitable technical background to enable him to understand the contents of this manual, including the diagrams found herein. The figures and descriptions in this handbook give both users and maintenance staff all the basic instructions to comply with when using and servicing the mower.

The user is responsible for ensuring that connection to the tractor and use of the mower complies with the current provisions in merit. The machine may only be used and serviced by persons who have become fully familiar with the contents of this manual, which should always be kept ready to hand. Users should become particularly familiar with chapter 2 concerning safety precautions.

Always comply with the given instructions. Consult the Major After-Sales Service Centre or your nearest dealer in case of doubt. In the event of faults or problems which require the assistance of a qualified technician, contact the manufacturer directly or your nearest dealer.

This machine is consigned according to the warranty conditions valid at the moment of purchase. The user must not tamper with the machine or make modifications to its parts since such action shall void the guarantee.

The manufacturer reserves the right to modify the machine specifications and performances without advance warning and declines all responsibility for any errors caused by incorrect installation or improper use of the equipment.

Contact MAJOR or your nearest dealer if there are substantial differences between the implement and the indications in this handbook. The standards that govern the guarantee are cited in the "Certificate of Guarantee" which is supplied to the user with this manual.



This symbol is used in the manual to call the reader's attention to various levels of danger that if not avoided will result in death or serious injury.

**Important:** References to this manual to the right side and left side of the machine mean to the right and left side of the operator seated in the tractors driving seat.

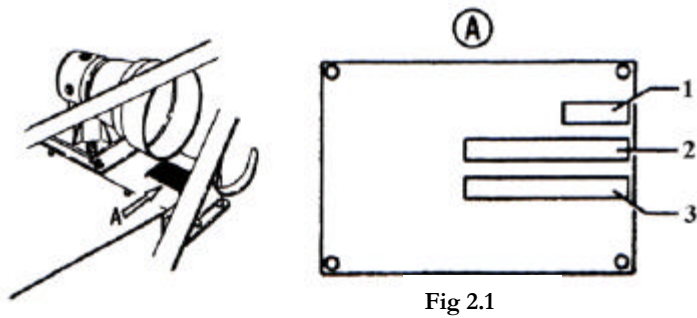
### **IMPORTANT NOTICE**

BEFORE OPERATING THIS MACHINE, BE SURE TO CHECK THE FOLLOWING CHECK-POINTS (HAVING FIRST STOPPED THE TRACTOR ENGINE, DISENGAGED THE PTO AND CAREFULLY READ AND UNDERSTOODF THE OWNER'S MANUAL):

1. Check oil levels (if necessary and SAE 90 EP oil)
2. Grease the driveline spiders
3. Grease all marked points on the machine
4. Check to be sure the nuts/bolts are snug on those parts which are under the most stress (tines, blades, front linkage bolts, gear box bolts etc)

## IDENTIFICATION DATA & GUIDE TO MAIN PARTS

The data plate indications must not be altered for any reason. We suggest that you write the data pertaining to your mower in the spaces below (Fig. 2.1)



1. Year of Manufacture
2. Machine type or model
3. Serial Number

### Key to the main parts

1. Three-point linkage used to couple the implement to the tractor.
2. Gearbox: Increases the rotation speed of the tractor PTO.
3. Chassis: This is the bearing structure of the implement.
4. Pivoting wheels: The machine is supported by pivoting wheels which can also be used to adjust the cutting height.
5. Rear discharge conveyor.
6. Side closing part.
7. Side discharge conveyor. (MR150 & MR180 only)
8. Rear closing part.

(Fig. 2.2)

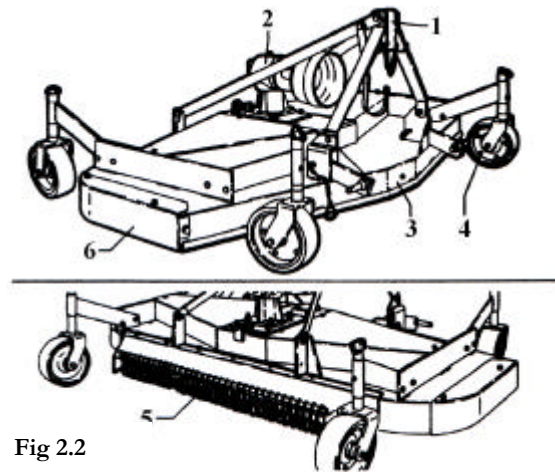
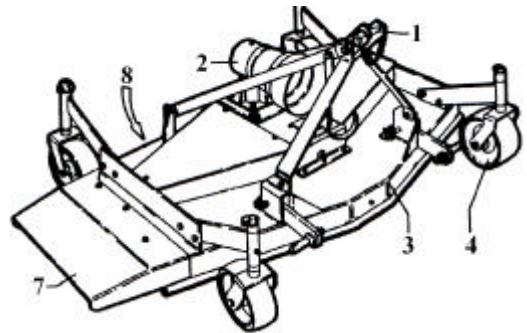


Fig 2.2

### Side Discharge Mower



The main feature of this machine is its versatility, since the user (if in possession of the transformation kit) can modify the machine from the rear discharge version to the side discharge version and vice versa. The essential parts of the machine are as follows: a

1. Kiln-lacquered, electro-welded steel frame;
2. A gearbox unit to be connected to the tractor's power takeoff with a PTO shaft.
3. Four pivoting wheels to support the machine on the ground while it is in use.
4. Three blades with a milled cutting edge.
5. Conveying and discharging set, positioned on the side or the rear of the machine.

## GENERAL SAFETY & SAFETY REGULATIONS



The mower must only be used with a suitable tractor and driven by an adequate driveline driven from the tractor PTO. All other use is strictly prohibited. Users should become thoroughly familiar with the contents of this manual before using, servicing or mounting the implement on the tractor and all other pertinent operations.



Never wear jewellery, loose clothing such as ties, scarves, belts, unbuttoned jackets or dungarees with open zips which could become caught up in moving parts. Always wear approved garments complying with accident prevention provisions such as: non-slip shoes, ear muffs, goggles and gauntlets.



Consult your dealer, the "Labour Health Service" or your nearest equivalent authority for information about the current safety provisions and specific regulations to comply with in order to ensure personal safety. If the machine is used in the evening, follow the relevant instructions.



### REGUALTIONS FOR THE USE OF THE DRIVELINE

The machine maybe supplied with a driveline; the driveline is complete with shields able to ensure the operator's safety (see Figure 3.6 page 8)

Keep the non-rotation shields efficient and in a good condition. If their condition is poor, they should be changed before the implement is used. Unless it is correctly protected, the driveline could even cause the user's death since it can catch on parts of the body or clothing. Always check that the shields are installed and perfectly efficient before using the machine. Check that they are well fixed and correctly inserted into their housings. Check that the retaining chains are correctly fixed to the tractor or mower in order to prevent the shields from turning together with the driveline.

Check that the driveline is free to turn within the shield. Take great care to prevent the shields from being damaged when the implement is coupled and released from the tractor. Keep the grooved parts perfectly clean and greased so that they are able to correctly slide.

Besides being described in this manual, the method by which the driveline is coupled must also be checked out with the instructions in the tractor manufacturer's manual. The correct rotation speed of the tractor PTO is indicated on the PTO shaft guards of each machine.

This rate is usually 540 or 1000 rpm. Always comply with the indicated speed. The following items are applied to the driveline (if delivered with the machine):

- A danger sticker on the shaft guard (**Fig. 3.1**)
- A danger sticker on the driveline which becomes visible if the shield is damaged or missing (**Fig. 3.2**)  
Strictly comply with the instructions on the sticker.



Fig. 3.1



Fig. 3.2



Fig. 3.3



Fig. 3.4





## **STARTING REGULATIONS**

1. Always check that any imminently dangerous condition has been appropriately eliminated before using the implement. Check that all guards and safety shields are installed, efficient and correctly mounted in place.
2. Never allow inadequately trained personnel to use the implement.
3. Before starting, always check that there are no persons, particularly children and animals, within the operative range of the implement. Examine the work area in order to become familiar with the type of soil in question. Check that there are no obstructions or objects in the area that could be caught up by the implement and thrown up at a distance. Clean all such objects from the area.
4. Never work near roads, paths, housing areas or places potentially frequented by people, vehicles, animals, etc. If such action is inevitable, check that these areas are deserted before beginning work and while on the job.
5. Never start the tractor before being correctly seated in the driving position. Never start a faulty implement, even when such a condition is only suspected. Contact your nearest dealer, or the person in charge, and ask for the implement to be inspected.



## **GENERAL OPERATION**

1. Never ever use the mower under influence of alcohol or the effect of medicines such as tranquillisers, sedatives, stimulants, drugs or any other substance as could slow or alter the reflexes or sight.
2. Never ever work when there are persons on the implement. No one must ride on the tractor apart from the driver unless this is explicitly allowed by the tractor manufacturer. The tractor must be equipped with a roll-bar and/or all other safety devices prescribed by the current laws in force. To ensure his personal safety, the operator must use these devices correctly. Consult and strictly comply with the instructions in the tractor use and maintenance manual.
3. The operator should never allow himself to be distracted when working. He should pay great attention and concentrate on what he is doing. Constantly keep the vehicle under control and always remember how to quickly stop and switch off both the tractor and implement.
4. Always check that children, adults and animals keep at an adequate safety distance from the mower when it is in use.
5. Take great care when working on sloping surfaces. It is preferable to work upwards or downwards rather than crosswise in order to avoid the risk of over-turning. Always check and comply with the tractor manufacturer's instructions, particularly in relation to the maximum gradient on which it is possible to work. When working on slopes, it is advisable to reduce the work speed, gradually varying the speed and direction of the vehicle during manoeuvres. Never repeatedly stop and start the machine.
6. Never operate on wet, slippery grass or soil or where the tyre grip is precarious. If such action is inevitable, always work at low speed to ensure the operator's safety. Pay great attention to any obstructions, stones or other objects which could hit the knives. The tractor engine must always be turned off, and the ignition key must be removed from the dashboard when intervening on the machine. For example, when it is necessary to detach the machine from the tractor or if grass or other objects that might have become tangled up in it must be removed.
7. Before dismounting from the tractor, always disengage the power takeoff (P. T.O.), turn off the engine, remove the ignition key from the dashboard, insert the brake, and do not approach the machine before the tools have come to a complete stop.
8. After having hit an obstacle, simultaneously stop the tractor and machine tool, turn off the engine, remove the ignition key from the dashboard, insert the brake, and check for any possible damage. If the machine has been damaged, all repairs must be carried out before continuing the working process. Always carry out any required repairs before continuing work. When the knives are turning, always keep the limbs well away from moving parts and those which heat during operation such as the over gear unit. Never ever attempt to check or adjust the belt tension while the implement is operating. Always stop it before this operation. Never ever lubricate the machine while it is operating, or when the PTO is engaged.
9. Never smoke while refuelling. Never refuel near smouldering, sparking material or open flames.
10. Always check whether the soil around the tractor is slippery. Clean all mud from the soles of the shoes before mounting the tractor. Keep the steps, bearing surfaces, handrails, shackles and tractor pedals (brake, clutch and accelerator) clean and free from all foreign bodies such as oil, grease, mud or snow in order to prevent all possibility of slipping or tripping.
11. Keep the operator support areas on the tractor free from mud or any thing else that could cause the operator to slip when the implement is mounted or demounted from the tractor. Never jump on or off the tractor. Always keep both hands and one foot well anchored. Never use the control levers or hose pipes as holds. These are mobile parts and do not offer a safe grip. Involuntary activation of a control could also cause the tractor or implement to accidentally move. Before the machine is released from the tractor, it should be rested on the ground in a stable position using the support foot where installed.



Always check that the machine is balanced and stable, then release it from the tractor, checking again to ensure that it is firmly positioned.



### **TRANSIT ON PUBLIC HIGHWAYS**

1. When driving on public roads, always comply with the Highway Code provisions in force in the country where the machine is being used. Pay particular attention near crossroads, underpasses, and level crossings, when meeting other vehicles, overtaking stationary or slower vehicles. Drive near the edge of the road and try not to hold up the traffic.
2. Never park the tractor and/or mower near crossroads, bends, level crossings or where the equipment could be a danger or obstruction to pedestrian traffic.
3. Never drive on public highways when the implement or tractor is particularly dirty since soil, grass and other items could drop on to the road and obstruct the normal road traffic. Disengage the PTO and disconnect the driveline when transporting the implement.



### **INSTRUCTIONS FOR MAINTENANCE TECHNICIANS**

1. The implement must be stationary and the tractor PTO disengaged before any work is carried out on the implement.
2. Routine and extraordinary maintenance operations must be carried out in a specially prepared place using correct and efficient tools. This place must always be kept clean and dry. There must be sufficient space around the implement to allow work to be easily carried out. Only trained and specialised personnel must be allowed to service the implement. Contact your nearest dealer when maintenance work is required.
3. Comply with the indicated bans and procedures when servicing the implement. Never ever use gasoline, solvents or other inflammable fluids as detergents. Use the non-flammable and non-toxic commercially available solvents authorised by the competent authorities. Never use compressed air or highly pressurised water to clean the implement. When this is absolutely inevitable, protect the eyes using goggles with side guards and use the lowest possible pressure.
4. At the end of the job, check and inspect the implement while it is still disconnected from the tractor. Check the cutting blades for wear. Never carry out welding operations without the manufacturer's permission and instructions. Before welding, always detach the implement from the tractor in order to prevent damage to the battery. Always wear a protective mask, goggles and gauntlets when welding, lapping or grinding, hammering or drilling. The implement should be lubricated as described the maintenance section (page 15).
5. Correctly remount all guards and shields that were removed during the maintenance and repair operations.



### **TEST REGULATIONS**

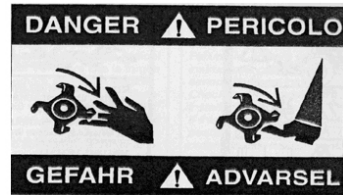
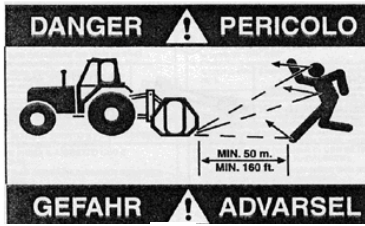
1. Always operate the machine outdoors. If the machine connected to the tractor must inevitably be started in a closed room, e.g. during tests after maintenance, always ensure that there is adequate ventilation to prevent harmful exhaust gas from accumulating.
2. Carry out various manoeuvres assisted by specialized personnel in order to simulate the different work conditions and acquire the necessary familiarity with the implement. Before starting, always check that there are no foreign bodies such as stones, soil or other, clinging to the rotors. When the rotor turns, such items could detach and be violently thrown notable distances. Always operate within a protective cage, or at least near a solid wall.
3. Always check that no one is too near or in a potentially dangerous position if the implement is to be operated raised from the ground, when testing for example.
4. Always disengage the PTO before driving the tractor to transport the implement from one place to the other.



### **WARNING DANGER PLATES AND STICKERS**

1. Comply with the warnings on the stickers. (See picture for locations & details of warning stickers on the machine) Failure to comply with the given instructions could cause death or serious personal injury.
2. Check that the stickers are always installed and legible. If this is not the case, contact your nearest dealer or "MAJOR" in order to obtain replacements (state the code number printed on the left hand side of each sticker when ordering).

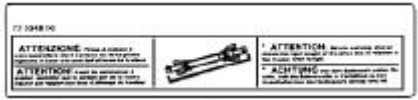
**STICKER NUMBERS & LOCATIONS**



1

2

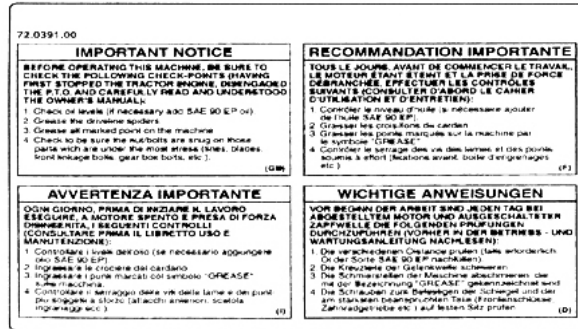
3



4



5



6



**KEY TO SAFETY DEVICES**

**1. PTO shaft guard.**

A cowling where the driveline couples with the shredder over-drive protects the rotating end of the driveline itself.

**2. Drive belt guard.**

Prevents access to the drive belts and pulleys.

**3. Snap Pin.**

Prevents the wheel with the fork slipping off accidentally.

**4 Driveline shield.**

The driveline is supplied with adequate plastic shields and relative fixing chains.

**5. Guards (only on the rear discharge version)**

Prevents the product leaking out of the side of the machine

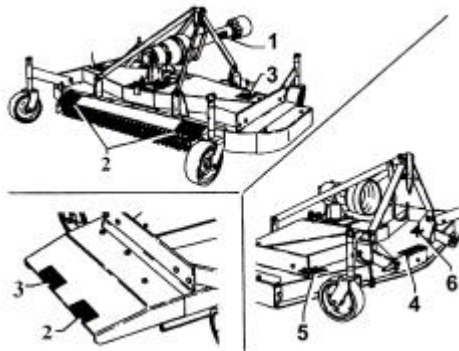
**6. Rear Guards**

Prevent any solid objects there may be in the earth from being ejected great distances.

**7. Safety Pin**

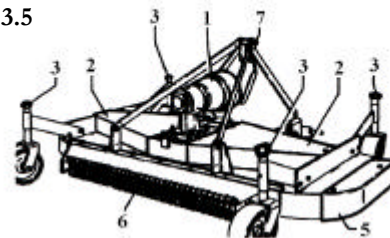
Prevents the pin in the attachment point slipping out accidentally. **Fig. 3.5**

6

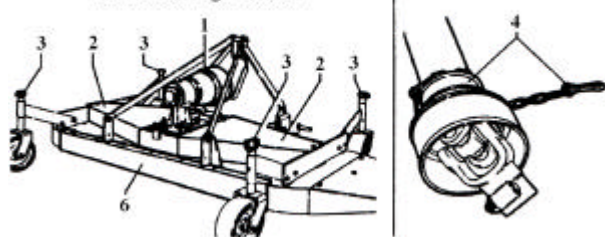


**Fig. 3.5**

**Rear discharge versi** MR150 & MR180 only



**Side discharge version**





## **NOISE**

Measurements of the noise issued by the machine indicate that the equivalent noise level is such as to maintain the daily level to which the operators are exposed within a value of less than 70 dBA. This measurement was made with a sound level meter set at a distance of about 1.6 m from the machine and at a height of 2 m, operated (no-load) at a PTO rotation rate of 450 rpm on grassy land. Please also note that the machine is normally used outdoors and that the position occupied by the operator is seated in the driving seat of the tractor. Also consult the prescriptions listed in the tractor use and maintenance manual.



## **VIBRATIONS**

During normal operation, the machine will not transmit appreciable vibrations to the tractor or, thus, to the operator. These vibrations are less than 2.5 m/sec<sup>2</sup>. to the operator's upper limbs and less than 0.5m/sec<sup>2</sup>. to the seated part of the operator's body. Consult the tractor manual for the vibrations transmitted by the tractor itself.



## **DISCLAIMER**

The mower has been built in compliance with the accident prevention regulations in force and therefore the manufacturer cannot be held responsible for damage resulting from:

- Use of the machine with faulty or missing guards
- Improper use of the machine
- Use of the machine by untrained or unauthorised personnel
- Incorrect assembly of the mower;
- Use of the mower on the wrong tractor;
- Lack of maintenance
- Unauthorised modifications or work carried out on the machine
- Use of non-original spare parts or those which are not specific to the machine
- Failure to observe all or some of the instructions & exceptional weather conditions.

## **DELIVERY OF THE MOWER**

All mowers are tested in our plants to ensure that all moving parts operate correctly. All items are thoroughly checked before dispatch or delivery. When the implement is received, always check that it has not been damaged during transport. Contact your dealer if such damage is discovered.

The machine is usually delivered partially disassembled and wrapped in a heat-sealed film. The disassembled parts are contained inside the packing, attached firmly to the machine

### **Hoisting & Handling the Packed Machine**

Do not place the packed machines on top of each other as the packing is not designed to be piled up.

- **Hoisting with a Forklift**

Open the forks as wide as possible, hoist the machine using a lift truck, with an adequate carrying capacity to lift the machine, checking its weight in the table on page 15. Check that the load is stable and well positioned on the truck forks.

Keep the load as low as possible when moving the implement. This will ensure greater stability and visibility.

- **Hoisting with a Crane or Bridge Crane**

There is a small eyelet in the upper part of the machine to facilitate its hoisting. When hoisting the machine, only hook up to this eyelet, not any other part. Take care to avoid swinging the load as this could be hazardous for the operator and the machine could be damaged. Use chains, cables and hooks whose capacity is greater than the load to be hoisted. Take particular care to use chains or cables that are intact and show no signs of fraying or wear, which could put the user's safety at risk.

## ASSEMBLING THE MOWER & HITCHING TO TRACTOR

Handle all the heavy parts with a hoist whose capacity is greater than the load to be hoisted. Make sure all the units and parts are supported by suitable harnesses and hooks. Make sure there is no one near the load to be hoisted. Handle all the parts with care. Never put your hands or fingers between the parts. Always wear approved accident prevention gear. Make sure the tools supplied with the machine are in good working order. Never use tools with upset or deformed heads. After the machine has had a part dismantled and then remounted, it must be tested to check the new part has been mounted correctly.

The mower may be supplied in a variety of ways:

- 1) mower with rear discharge;
- 2) mower with side discharge;
- 3) mower with rear discharge and side discharge transformation kit;
- 4) mower with side discharge and rear discharge transformation kit;
- 5) mower-machine base and transformation kit for both side and rear discharge versions.

Important: The user is responsible for the following:

- the assembly of the separate pieces;
- transforming the machine from rear to side discharge versions or vice versa.

The operator responsible must have the necessary skills and background to carry out the operations required correctly and safe

### **Assembling the Mower – With Rear Discharge Unit**

Ref No	Description	
1	Three point attachment	
2	M12 x 20 Screw	(UNI 5737)
3	M10 x 30 Screw	(UNI 5739)
4	M10 Nut	
5	M12 Nut - Auto Lock	
6	M12 x 35 Screw	(UNI 5739)
7	M12 Nut - Auto Lock	
8	M12 x 35 Screw	(UNI 5739)
9	M12 Nut - Auto Lock	
10	Wheel with support	
11	M12 x 40 Screw	(UNI 5739)

Ref No	Description	
12	M12 Nut - Auto Lock	
13	Guard	
14	M8 x 20 Screw	(UNI 5739)
15	Conveyor	
16	M10 x 20 Screw	(UNI 5739)
17	Washer M10	
18	Washer M10	
19	M10 x 20 Screw	(UNI 5739)
20	Guard	
21	Washer M10	
22	M10 x 20 Screw	(UNI 5739)

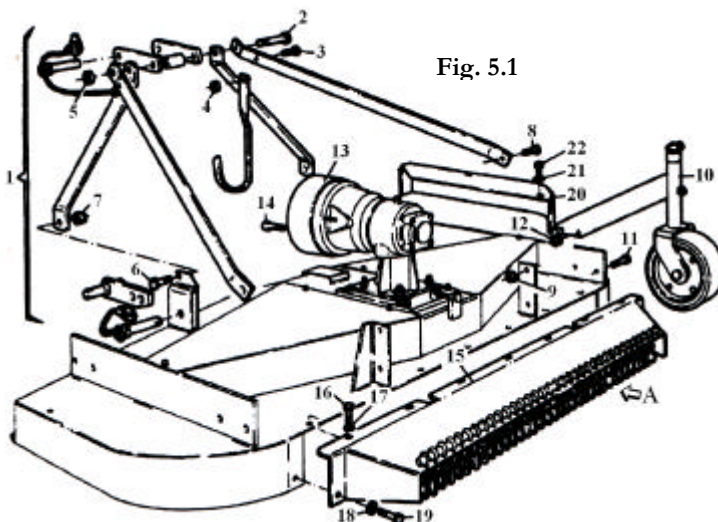


Fig. 5.1

- Mount the three-point attachment "1" on the machine base using the relative screws, nuts and pins
- Mount the guard 13 using the screws "14".
- Mount the four wheels "10" using the screws "11" and the nuts "12".
- Mount the conveyor "15" using the screws "16" and "19" and the washers "17" and "18". **Fig. 5.1**

**WARNING:** Make sure all the guard chains "A" are mounted in the correct position. Mount the guard "20" using the screws "22" and the washers "21"



## Assembling the Mower – With Side Discharge Unit

Ref No	Description	
1	Three point attachment	
2	M12 x 20 Screw	(UNI 5737)
3	M10 x 30 Screw	(UNI 5739)
4	M10 Nut	(UNI 5588)
5	M12 Nut - Auto Lock	
6	M12 x 35 Screw	(UNI 5739)
7	M12 Nut - Auto Lock	
8	M12 x 35 Screw	(UNI 5739)
9	M12 Nut - Auto Lock	

Ref No	Description	
10	Wheel with support	
11	M12 x 40 Screw	(UNI 5739)
12	M12 Nut - Auto Lock	
13	Guard	
14	M8 x 20 Screw	(UNI 5739)
15	Conveyor	
16	M10 x 20 Screw	(UNI 5739)
17	Washer M10	

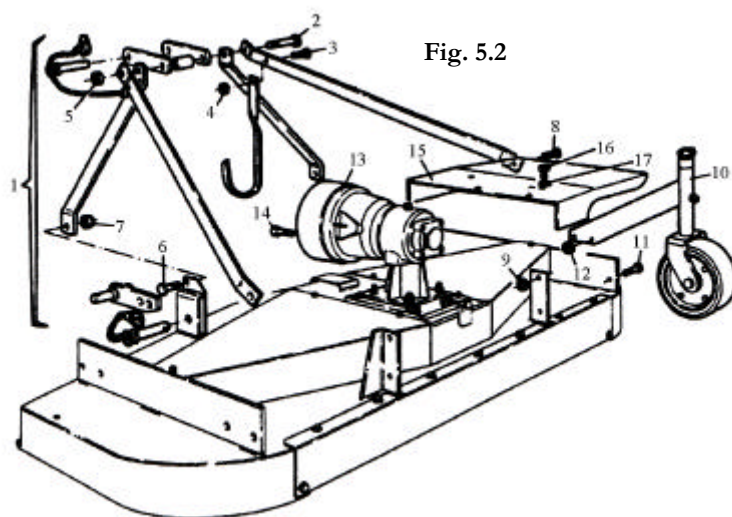


Fig. 5.2

- Mount the three-point attachment "1" on the machine base using the relative screws, nuts and pins.
- Mount the guard "13" using the screws "14".
- Mount the four wheels "10" using the screws "11" and the nuts "12".
- Mount the conveyor "15" using the screws "16" and the washers "17". **Fig. 5.2**

## Transforming the Rear Discharge Mower into the Side Discharge Version (MR150 & MR180 only)

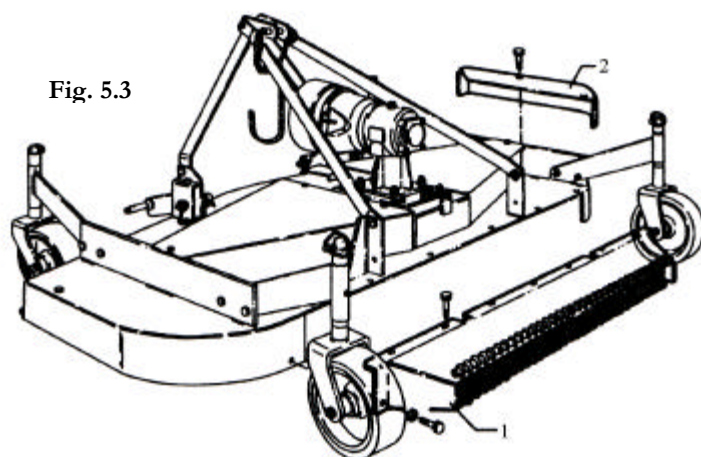


Fig. 5.3

- Step 1:**  
Dismount the rear conveyor "1";  
Dismount the guard "2".  
**Fig. 5.3**

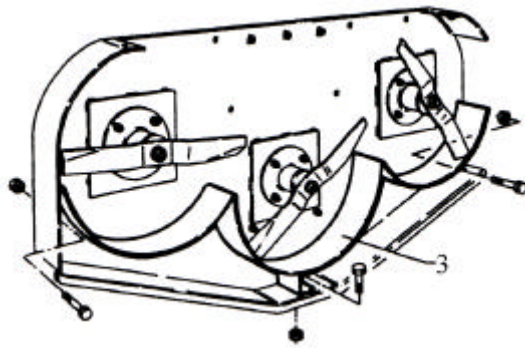


Fig. 5.4

**Step 2:**  
Dismount the internal conveyor "3".  
**Fig. 5.4**

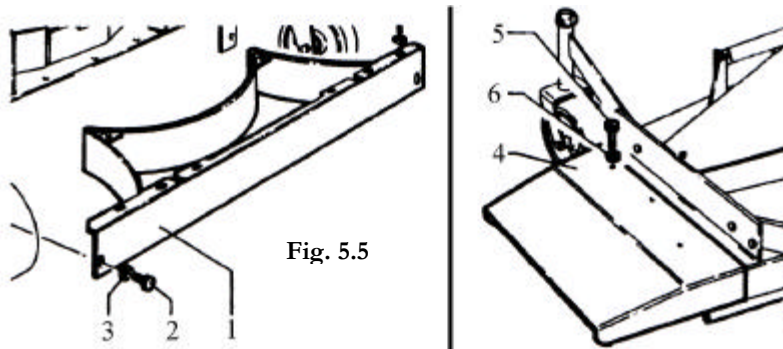


Fig. 5.5

**Step 3:**  
Mount the rearguard "1"  
using the screws "2" and the  
washers "3".  
Mount the side conveyor "4"  
using the screws "5" and the  
washers "6".  
**Fig. 5.5**

### Transforming the Side Discharge Mower into the Rear Discharge Version

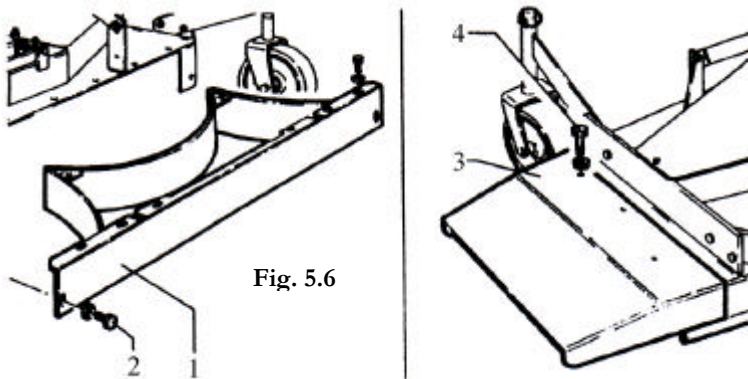


Fig. 5.6

**Step 1:**  
Unscrew screws "2" and  
dismount the rearguard "1";  
unscrew screws "4" to  
dismount the side guard "3".  
**Fig. 5.6**

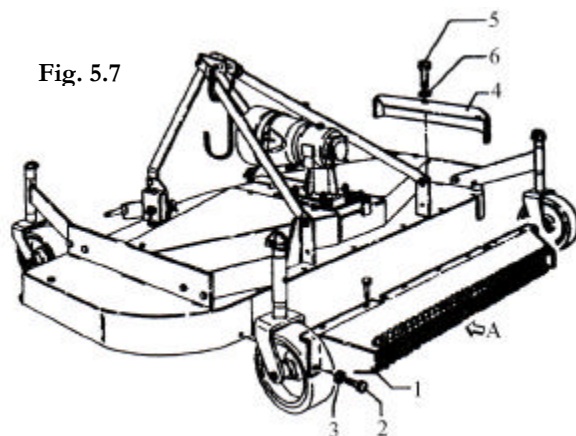
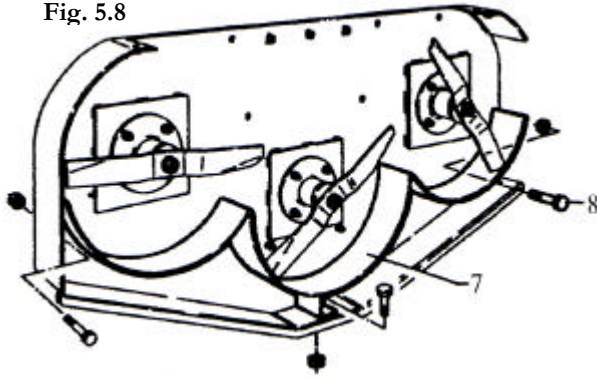


Fig. 5.7

- Step 2:**
- Mount the rear conveyor "1" using the screws "2" (M10x20UN15739) and the washers "3" (0 10).
  - Mount the side guard "4" using the screws "5" (MI Ox 20 UN1 5739) and the washers "6" (0 10).

**WARNING:** Make sure all the guard chains "A" are mounted in the correct position. **Fig. 5.7**  
Mount the guard

Fig. 5.8



**Step 3:**  
Mount the guard "7" using the screws "8" **Fig. 5.8**

### Hitching the Mower to the Tractor

Check that all the guards and shields listed on page 6 are installed and efficient. Always operate on a flat and levelled surface when hitching the implement to the tractor. This will prevent dangerous movements.

Keep the hands and feet well away from the knives when hitching the mower to the tractor. Never allow anyone to stand between the tractor and the mower.

The implement must be used with a suitable tractor. Pay particular care when checking the following conditions:

- **Stability** - the weight and dimensions of the implement must suit the technical specifications of the tractor. An initial indication as to the most suitable tractors is given in the "Average power" column in technical data information on page 15 and introduction
- **Maximum tractor power rating** - Consult the values in the "Maximum power" column on page 15 – Technical Data
- **PTO speed** - Consult the values in the "PTO speed" column on page 15 – Technical Data when choosing the work speed.

The user shall ensure that the implement is fit for use with the tractor in his possession.

Prevent damage to the gears by checking the level of lubricant in the gearbox before using the mower. Top up with oil of the same type if necessary. Check that the rotors supports have been greased. Consult page 15 for the required type of lubricant. Check that the blades are free from foreign bodies. Very worn or broken knives must be replaced in compliance with the instructions in Maintenance section – page 15. Check that all warning and danger stickers are installed and legible. Replace them if necessary. Check that the tractor is in a good condition. Check the oil levels in the engine, gearbox and brakes. Check the cooling water level and tyre pressure. Always refer to the instruction manual supplied with the tractor.

Reverse the tractor towards the mower, aligning the tractor lift links with the two side coupling pins "1" (**Fig. 5.9**) Turn off the tractor engine, remove the ignition key from the dashboard and insert the brake.

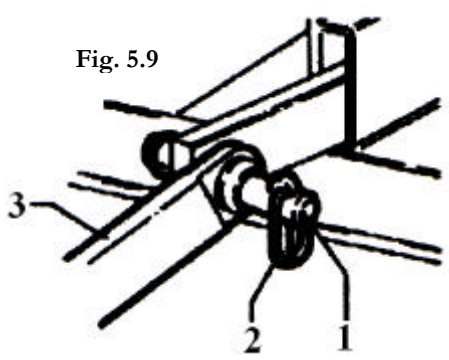


Fig. 5.9

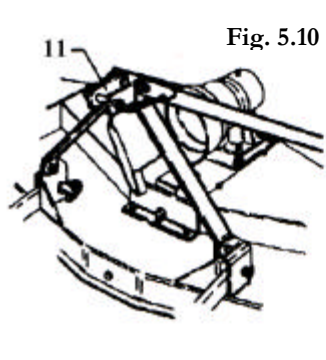


Fig. 5.10

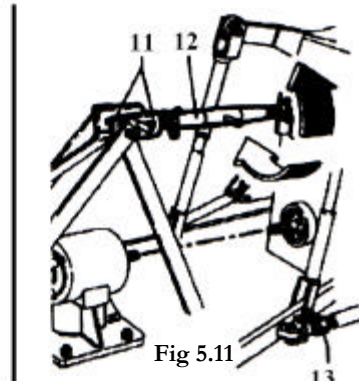


Fig 5.11

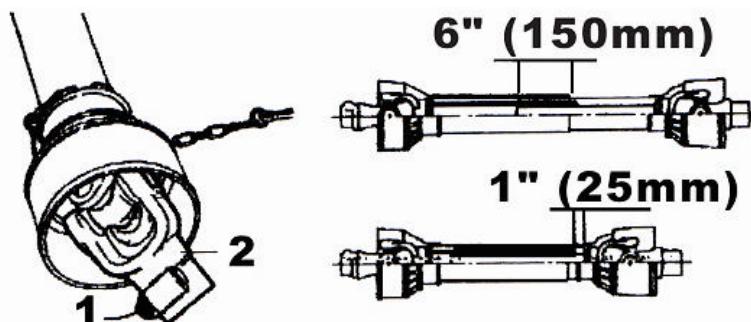
Insert the ends of the lift links into implement coupling pins "1". Fix them in place by means of the relative safety pins "2" (**Fig. 5.9**) Fix the top link "12" (**Fig. 5.10**) of the three-point hitch "11" and adjust it until the PTO of the implement is parallel to the ground. If used on uneven land, fix rod "12" into the oval hole.

Start the tractor engine and lift the mower from the ground. Now switch off the tractor engine. Operate lift link rod "13" to prevent excessive oscillations to the side. Oscillation of about 50 mm each side (2 inches) is



recommended. Level the mower at the sides by adjusting the tractor lift links. The knives must be at the same distance from the ground on both sides of the implement. Mount the driveline, checking that it correctly meshes at both ends.

Consult the descriptions on the following pages for greater details. If a safety system is required, this must be mounted from the side of the implement and not from the side of the tractor. Check that the driveline is the correct length



The minimum coupling length must be no less than 150 mm (6 inches) in each work position. Driveline travel must still be about 25 mm (1 inch) in the maximum coupling position. **(Fig. 5.11)**

These are the correct regulations for safe working conditions. If the driveline is too short and tends to slip out of place, it must be replaced with a longer one

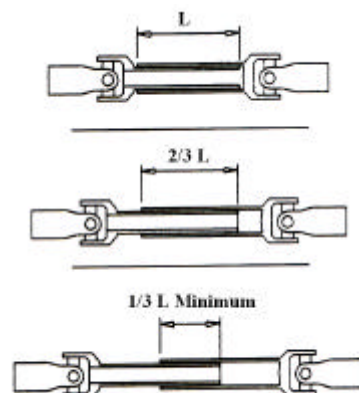
#### PTO SHAFT LENGTH

The tractor PTO shaft length may be altered to suit the individual tractor model. When the machine is in operation, the PTO shaft should have a minimum 1/3 engagement as shown in the diagrams to the right. **(Fig. 5.12)**

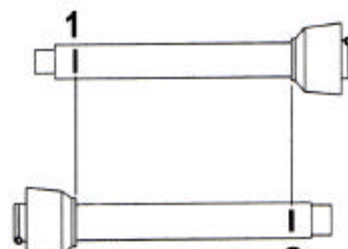
Contact your nearest dealer or a specialised retail outlet if the PTO must be replaced with a longer one, since this must belong to the same power category and possess the same characteristics

If the PTO shaft is too long, it should be shortened in the following way:

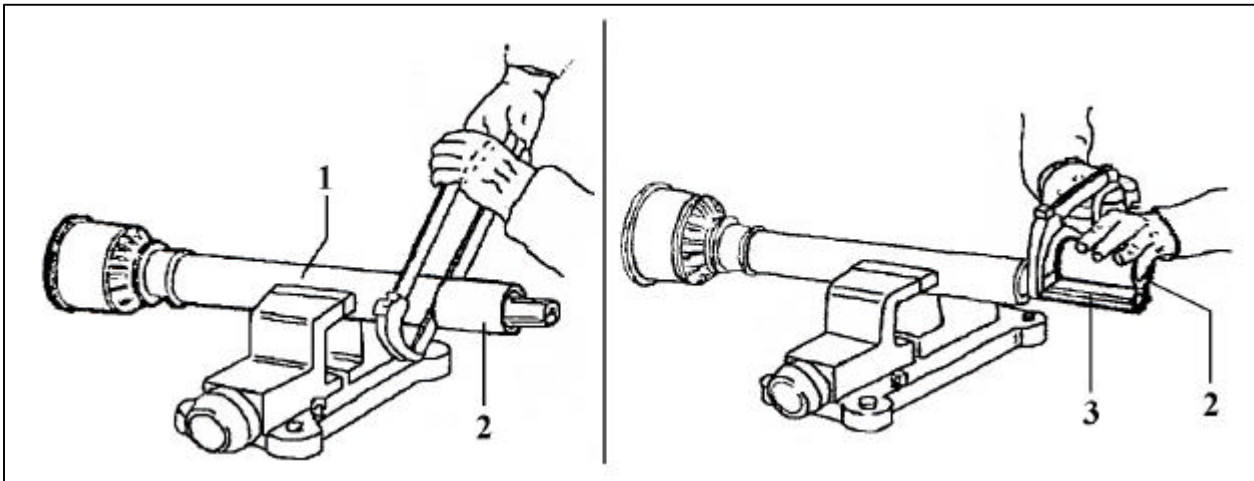
- Set the machine at a minimum distance from the tractor, the brake the tractor and switch off the engine.
- Separate the two halves of the PTO. Insert the female part into the tractor PTO and the male part into the mower PTO, checking that the position is correct by means of the fixing pins.
- Near the two halves of the PTO together, keeping them parallel.
- Using a marker pen, match mark the place where the two halves must be shortened as shown.
- First cut shield "1" and use part "2" as a reference to cut the splined shaft. **(Fig 5.13)**
- Proceed in the same way for the second half.
- Trim and chamfer the two cut ends of the PTO and clean off all swarf and shavings. **(Fig 5.14)**
- Grease the two profiles and join the two halves of the PTO together again.
- Mount the PTO shaft and check that its length is correct as before. The shaft must not reach the end of the tube or project from this.



**Fig. 5.12**



**(Fig 5.14)**



## **OPERATION & USE OF THE MOWER**

### **Driving on the Roads**

When driving on public roads with the mower attached to the tractor, always respect the highway code. Check that the reflectors, hazard flashers and/or slow vehicle and/or projecting load indicators are installed when required, and efficient. These indicators must be installed at the rear of the implement. They must be clearly seen by the drivers of other vehicles behind. If the implement must be transported at night or in other conditions of poor visibility, it should be equipped with sidelights of the type approved by the Highway Code regulations in force. During transport, the mower should be kept completely lifted with the PTO disengaged. No one must be allowed to lean against and/or climb on to the mower during either work or transport.

### **Preparing the Mower for Work**

Always be careful to check that the power rating of the tractor used to tow the implement does not exceed the maximum power rating for the model in your possession (Consult Maintenance Section page 15). Check that the speed of the PTO complies with the speed required by the implement. Compare the values on the shield of the PTO shaft.

**IMPORTANT:** Comply with these instructions in order to prevent early faults and damage to the implement.

Every time the mower is adjusted, the procedure must be as follows:

- Disengage the power takeoff;
- Insert the tractor brake;
- Turn off the tractor engine;
- Remove the ignition key from the dashboard.

Keep body parts clear of the rotating blades. Wait for them to stop moving.

The cutting height is regulated by the four wheels. All four wheels must be adjusted in the same way so that the machine will cut the grass uniformly and will not be damaged.

### Adjusting the Cutting Height – Fig 6.1

To alter the cutting height, proceed as follows:

- Remove the split pin 1
- Slide out the wheel axle 2;
- Slide the spacers supplied with each wheel or parts of these spacers onto the wheel axis 2 according to the height required.
- Mount the wheel axle 2 onto the wheel support 3, slide any remaining spacers on and lock them in place with the split pins 1 (see fig. 6.1). The spacers are all different-sized to enable the height to be altered as accurately as possible. The more spacers are placed below the wheel support "3", the further away the blades will be from the ground (until reaching the maximum cutting height).

**IMPORTANT:** However the spacers are laid out, the wheel axle must have the minimum clearance.

**CAUTION:** Always check that the driveline is unable to touch the implement when the mower is raised from the ground.

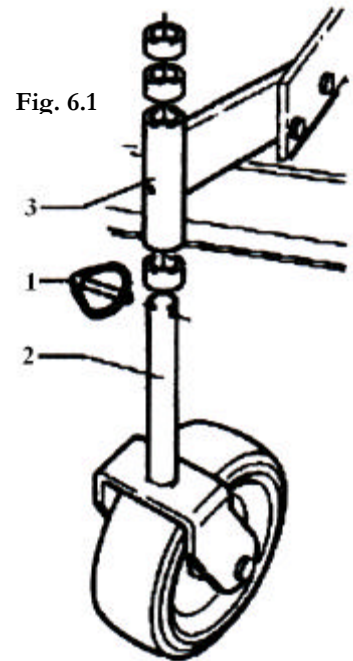


Fig. 6.1

### Using the Mower

Before working always check that all the safety shields listed in page 6 are installed, correctly mounted and efficient. Failing this, stop the mower and replace or repair the damaged shields. Never continue work until all the shields installed by the manufacturer are efficient. Contact your nearest after-sales service centre if necessary. Always become familiar with mower use before working with the implement. Make sure that you know how to quickly stop the work operations.

Step 1: Lower the machine until the four wheels are resting on the ground.

Step 2: If any further adjustments are necessary, carry out the work as described in the paragraph – Adjusting the Cutting Height

Step 3: Accelerate the tractor by depressing the accelerator pedal to about half its travel and then engage the PTO.

Step 4: Advance with the tractor, setting the PTO to the required rpm rate (usually 540 or 1000 rpm). The travelling speed of the tractor must be selected according to the grass to be cut, its quantity and the cutting finish required. Optimum work speeds will be between 3 and 8 Km/hour (2/5 mph).

Important:

- The cutting finish will be better if the tractor travels slowly while operating. Always raise the implement from the ground during manoeuvres, round bends and when reversing. After having worked for a few meters, stop and check whether the desired result is being obtained. Make any adjustments as may be necessary and then continue with the job.
- Never reverse with the implement unless this is strictly necessary. In such cases, disengage the pto and carefully check to see whether there are any obstructions at the rear.

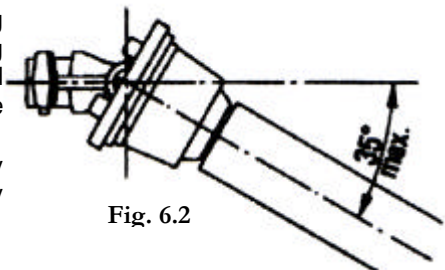


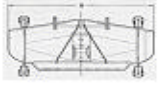













Fig. 6.2

- Never lift the implement more than 250 mm from the ground with the pto engaged or the driveline could break and risk injury to the operator. The maximum tilt the driveline can bear with the PTO engaged is 35° (Fig. 6.2).

## Demounting the Implement from the Tractor

- Disengage the PTO. Set the implement on a flat surface. Stop the tractor and engage the parking brake.
- Rest the mower on the ground.
- Switch off the tractor engine.
- Remove the ignition key from the dashboard.
- Remove the driveline.
- Block the mower's wheels with wedges or other suitable means.
- Detach the implement from the tractor by disconnecting the three-point hitch.

## MAINTENANCE OF THE MOWER

<b>Technical Specifications</b>											
	 Overall Width		 Working Width		 HP Requirement		 Blades	 PTO Speed	 Rotor Speed	 Weight	
	Standard mm	with side discharge	mm	inch	Min	Max	Qty	RPM	RPM	kg	lbs
<b>MR-150</b>	1540	1740	1500	60	15-30	40	3	540	2590	210	450
<b>MR-180</b>	1840	2045	1800	72	20-40	40	3	540	2235	245	540
Standard Equipment: 3-Point linkage cat. 1 with floating brackets - 2 belt transmission with tensioner - 4 pivoting rubber wheels - Adjustable working depth through spacers - Standard drive line											
<b>Technical Specifications</b>											
	 Overall Width		 Working Width		 HP Requirement		 Blades	 PTO Speed	 Rotor Speed	 Weight	
	Standard mm	with side discharge	mm	inch	Min	Max	Qty	RPM	RPM	kg	lbs
<b>MRP-235</b>	2370	2575	2330	92	30-40	40	5	540	2720	310	680
Standard Equipment: 3 point linkage cat. 1 - 2 belt transmission with tensioner - 4 pivoting rubber wheels - Adjustable working spaces depth trough spacers - Complete with grease extensions - Rear discharge - Standard drive line.											



The machine must always be disconnected from the tractor before any cleaning, lubricating and servicing operations are carried out. If interventions must inevitably be carried out while the machine tool is still attached to the tractor, proceed as follows:

- disengage the power takeoff;
- insert the brake;
- turn off the tractor engine;
- remove the ignition key from the dashboard.

To prevent all risks, the operator should not merely trust in the hydraulic system of the tractor since this can be liable to leaks able to lower the machine even when the engine is off. Always block the machine with a rigid support when work must be carried out underneath.

Good, regular maintenance and correct use are essential if the mower is to remain safe and long lasting. Respect the following rules, which can also be found on the plates attached to the machine.

## Checks made in our Factory

Your implement will have been subjected to various tests and trials both in our factory and on the dealer's premises. This procedure ensures that operation and the necessary adjustments will be correctly carried out. In particular, the following inspections are made:

1. The implement is checked to see that the serial number and all stickers have been affixed.
2. All points are greased as described in Fig 7.5. The oil level in the gearbox is also checked.
3. The transmission belts are checked to ensure that their tension is correct.
4. Check for oil leaks.
5. Check to see that all safety devices are installed and efficient.
6. General inspection during operation.

## Inspection before use

Inspect the knives to ensure that they are free from foreign bodies. Check the implement for wear and damage. Particularly check that the knives, the drive belts and wheels are in a good condition. Check that all nuts and bolts are fully tightened, with particular reference to the knife bolts. Check that the oil and greases in the various points are at the correct level, as described below. Despite the previous inspections, lubricant may have partially spilt during transport and need topping up.

## Inspections to be made periodically

### Every 8 hours service

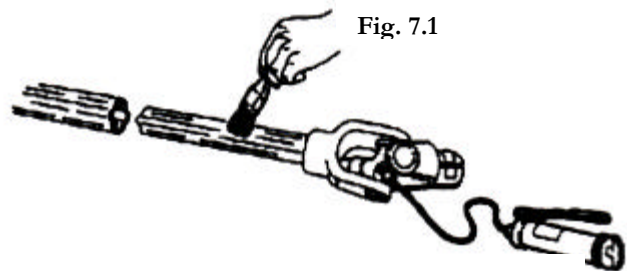
- Grease the rotary shaft supports (see diagram below).
- Check the condition of the driveline and grease the joints
- Grease the wheel axles.

### Every 50 hours service

- Check the belt tension.
- Check the oil level in the gearbox.
- Check the knives for wear. Replace them if necessary, in compliance with the instructions in paragraph below.
- Demount and clean the driveline. Be sure to remove all foreign bodies from the sliding parts of the shaft.
- Cover the sliding parts with grease before remounting the driveline. Check that all nuts and bolts are fully tightened.

### Every 250 hours service

- Change the oil in the gearbox. Consult paragraph below for the recommended type of oil. The following operations must be performed when carrying out the work required:
- Using a clean brush, spread a film of grease on the surfaces of the sliding section. (**Fig 7.1**) Consult paragraph below for the recommended type of grease.
- Grease the journals until grease oozes from all the articulations of each journal.



## Cleaning & Greasing the Driveline

- Remove the splined parts.
- Using non-toxic and non-inflammable solvents, degrease the dirty parts, particularly the sliding grooved sections and universal couplings. Use non-toxic, non-inflammable solvents to prevent the risk of intoxication or fire outbreaks

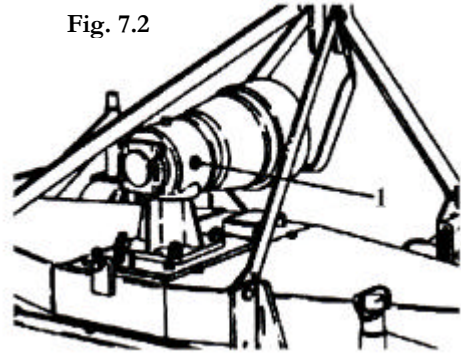


### Check & Changing the Oil in the Gearbox

**IMPORTANT:** The used oil is a pollutant and must be disposed of correctly. Pour it into a suitable container and take it to the special oil collection points.

- Check the oil in the gearbox: Check the level of the lubricant through the plug "1", the oil must reach the lower edge of the hole of level plug. (Fig 7.2)
- Changing the oil in the Gearbox: Change the first oil fill after the first 50 hours service. Following this, the oil should be changed after every 250 hours service. Consult below for the recommended type of oil.

Fig. 7.2



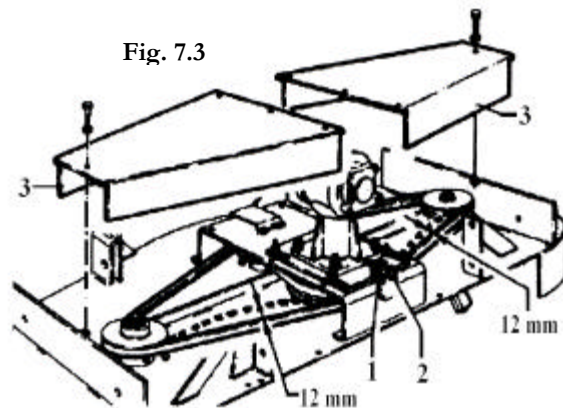
### Checking the Belt Tension

Work should only be carried out on the transmission belts when the tractor has been turned off, the ignition key is not in the ignition, the parking break is in position and the drive has been disconnected. When possible, such operations should only be carried out after the shredder has been disconnected from the tractor.

Dismount the casings "3". (Fig 7.3)

- The belts are fitted correctly if, when pressing down, with one hand, halfway between the multiplier pulley and the rotary shaft, the belts yield by approximately 12mm (1/2 inch).
- To tighten the belts, loosen the nut "1" and turn the screw "2" until the belt is as tight as required.
- When the belt has been tightened as required, use the nut to lock it in place.

Fig. 7.3



**IMPORTANT:** Make sure the belts are intact, that they are not cracked and do not have ragged edges. If this is not the case, replace them with new belts.

### Check & Replacing Blades

**IMPORTANT:** It is advisable to replace all the blades at the same time to prevent the machine vibrating. When mounting the new blades, make sure the cutting edges are positioned in the direction the rotor rotates in.

- Place the machine at a comfortable height and lock it in position with sufficient support to guarantee the operator's safety. Prevent the blade rotating by locking
- the shaft with a key (the shaft is designed for this with two flat areas immediately above the blade)
- Using the key, unscrew the nut "1" and remove the blade. (Fig. 7.4)
- Check the state of wear of the pin and the nut and, if necessary, replace them.
- Mount the new blade, screw in the nut "1" fully and with force, keeping the shaft locked at the same time as described above.

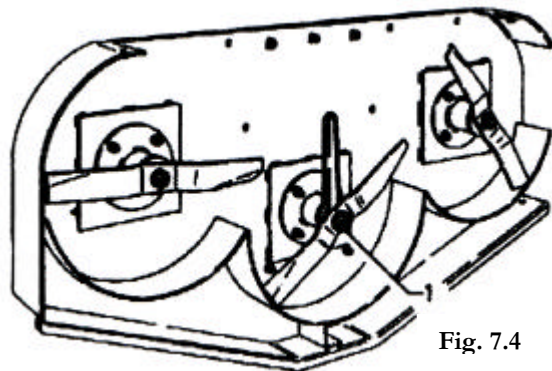
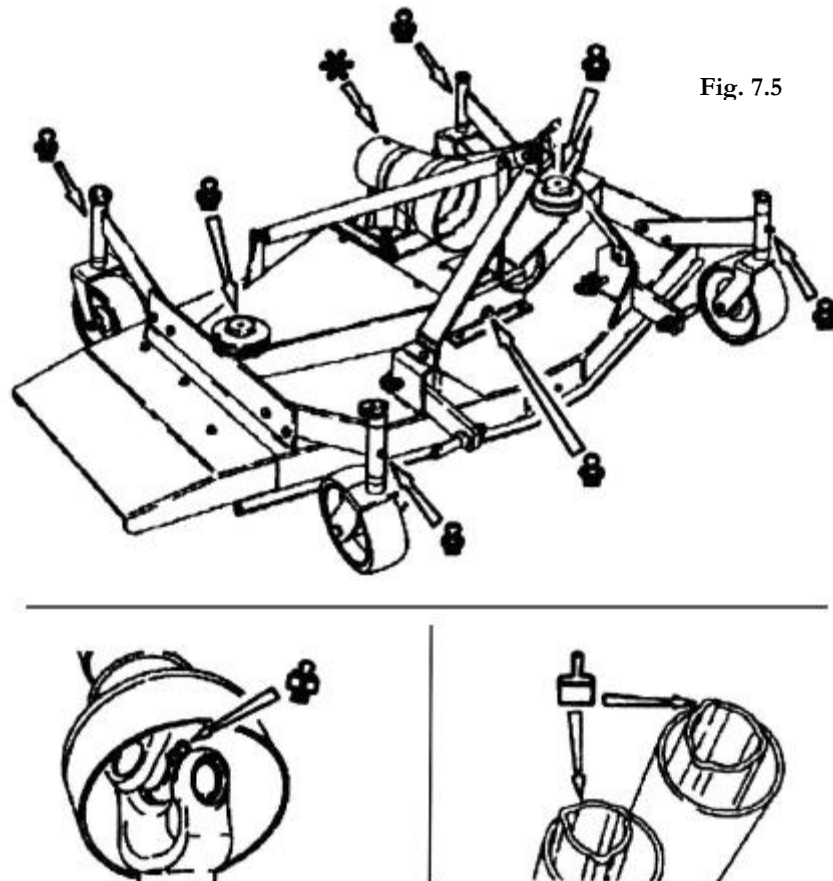


Fig. 7.4

### Cleaning the Machine

IMPORTANT: When cleaning the machine, only use non-toxic, non-inflammable solvents with water cleaning machines. Wear accident prevention gear which is suitable for the task in hand, e.g. goggles, gloves and waterproof overalls.

### Lubricant & Greasing Points (newer models now have grease extensions)– Fig. 7.5



### Table of Recommended Lubricants

	AGIP	ESSO	IP	SHELL
Gearbox Oil	ROTRA MP85W/140  BLASIA 460	GEAR OIL EP 320	MELLANA OIL 460	OMALA OIL 460
Grease	GREASE 30 GRUMU3	BEACOM E.P.3	ATNESIA GR3	SUPER GREASE R3



## **How to Store the Mower for Long Periods**

- Clean all dirt from the implement. Take particular care to remove any foreign bodies from the blade.
- Park the mower on a flat surface, in a sheltered place inaccessible to either children or animals in a stable position to prevent it from moving (for this purpose it is advisable to stop the wheels with wedges or other suitable means), falling or being fitted over etc.
- Check that the weight of the machine is not too heavy for the surface on which it rests (consult the weight chart on the front page of this booklet)

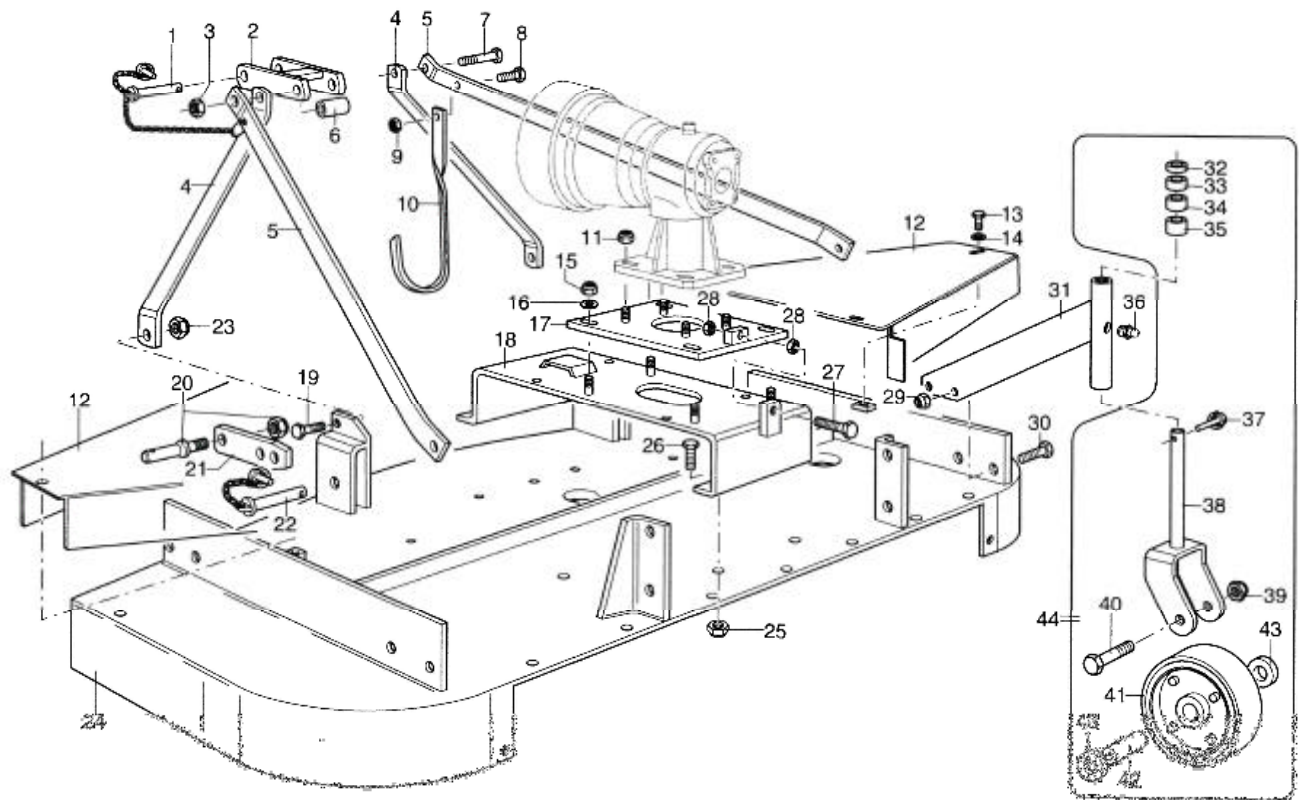
## **Disposing of the Machine**

When scrapping the machine, the procedure to adopt is as follows: remember that it is almost completely made of ferrous material. The only potentially polluting components on the machine are the lubricants. To prevent them from polluting the environment, spread a waterproof tarpaulin on the ground, position the machine on this and then drain out the lubricants which must be collected in suitable containers. Now dismantle the machine, separating the components in the following way:

- Painted parts
- Ferrous parts
- Plastic parts
- Rubber parts

Contact those companies that are legally authorised to dispose of such materials.

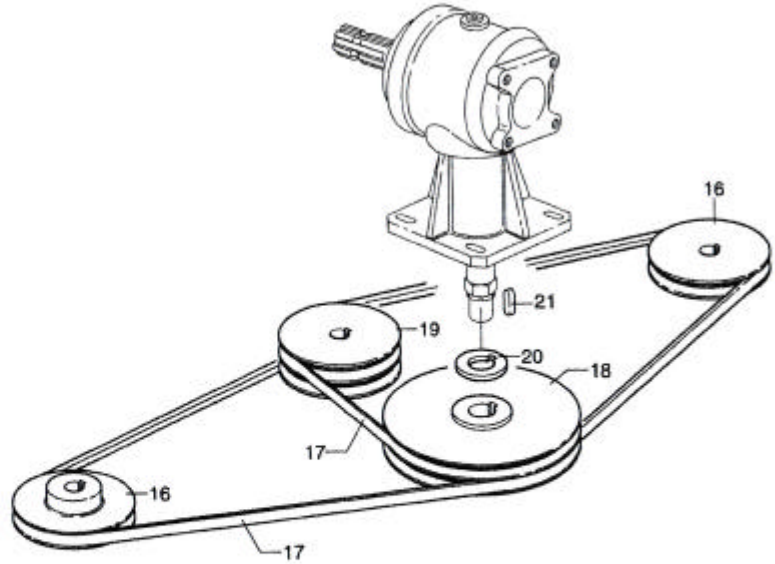
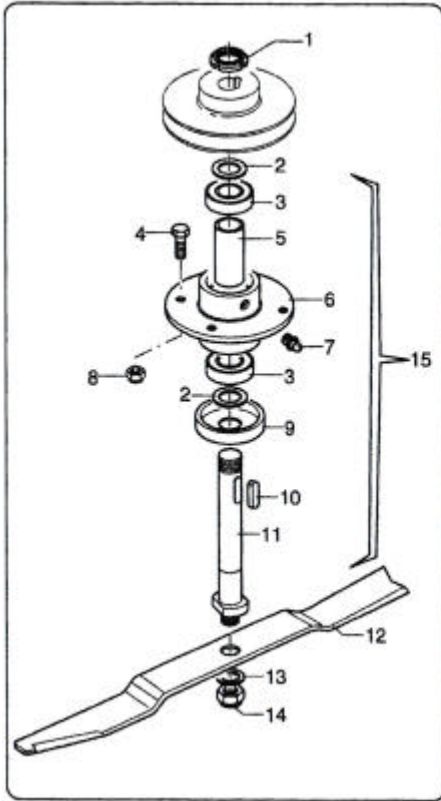
# KIT FOR FRAME – MR150 & MR180



Item No.	Description	Qty	MR150 Part No.	MR180 Part No.
1	Pin	1	68062000	68062000
2	Attachment	1	40237800	40237800
3	Nut	1	62010600	62010600
4	Tierrod	2	30178900	30178900
5	Tierrod	2	30182900	3018300
6	Spacer	1	32021400	32021400
7	Screw	1	60011900	60011900
8	Screw	1	60021300	60021300
9	Nut	1	62010400	62010400
10	Hook	1	30120100	30120100
11	Nut	4	62011000	62011000
12	Casing	2	39259300	39259400
13	Screw	6	60024600	60024600
14	Washer	6	61004700	61004700
15	Nut	4	62010400	62010400
16	Washer	4	61004900	61004900
17	Counter Plate	1	40233800	40233800
18	Support	1	40234000	40234000
19	Screw	4	60021200	60021200
20	Pin	2	68062500	68062500
21	Arm	2	40239400	40239400
22	Pin	2	68062000	68062000

Item No.	Description	Qty	MR150 Part No.	MR180 Part No.
23	Nut	4	62010600	62010600
24	Frame	1	41111400	41111500
25	Nut	2	62010400	62010400
26	Screw	5	60017900	60017900
27	Screw	1	60033900	60033900
28	Nut	2	62007000	62007000
29	Nut	8	62010600	62010600
30	Screw	8	60028200	60028200
31	Bracket	4	40234200	40234200
32	Spacer	4	32174600	32174600
33	Spacer	4	32174700	32174700
34	Spacer	4	32174900	32174900
35	Spacer	4	32175000	32175000
36	Grease Fitting	4	64000200	64000200
37	Pin	4	64004800	64004800
38	Yoke	4	40234300	40234300
39	Nut	4	62010600	62010600
40	Screw	4	60033000	60033000
41	Wheel	4	68076400	68076400
42	Bushing	4	38023500	38023500
43	Spacer	8	32174900	32174900
44	Wheel Assembly		45115200	45115200

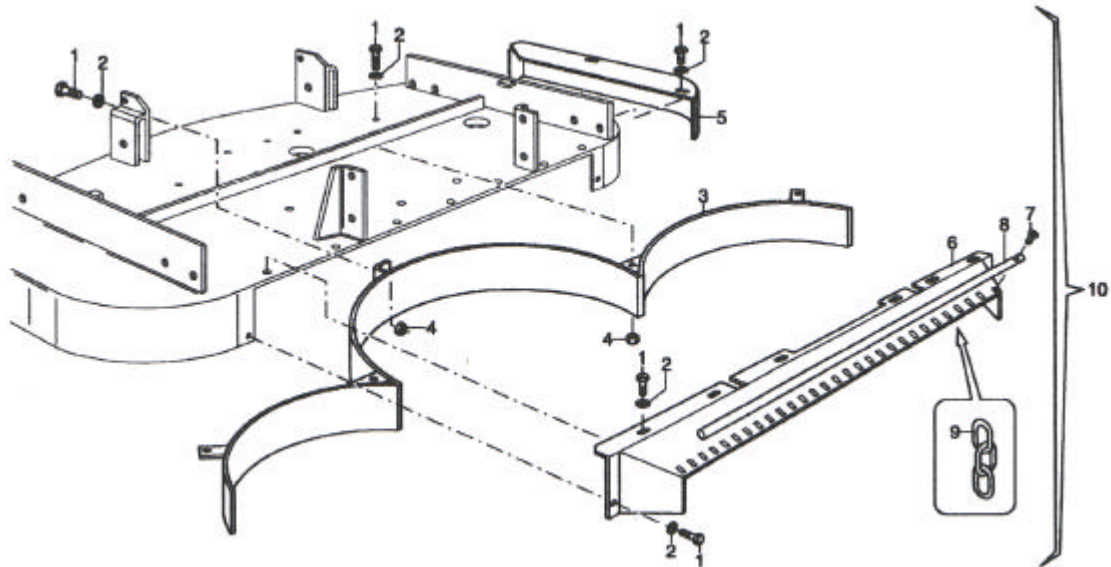
## TRANSMISSION ROTORS – MR150 & MR180



Item No	Description	Qty	MR150 Part No	MR180 Part No
1	Ring Nut	3	62001200	62001200
2	Spacer	6	32174100	32174100
3	Bearing	6	67016600	67016600
4	Screw	12	60021300	60021300
5	Spacer	3	32174000	32174000
6	Support	3	40234100	40234100
7	Grease Fitting	3	64001800	64001800
8	Nut	12	62010400	62010400
9	Guard	3	39261100	39261100
10	Key	3	65001100	65001100
11	Shaft	3	31078600	31078600

Item No	Description	Qty	MR150 Part No	MR180 Part No
12	Blade	3	12017800	12027900
13	Washer	3	39077800	39077800
14	Nut	6	62011100	62011100
15	Spindle Assembly		45115100	45115100
16	Pulley	2	68086700	68086700
17	Belt	2	68086900	68087000
18	Pulley	1	68086200	68086300
19	Pulley	1	68086500	68086500
20	Spacer	1	32173800	32173800
21	Key	1	65000200	65000200

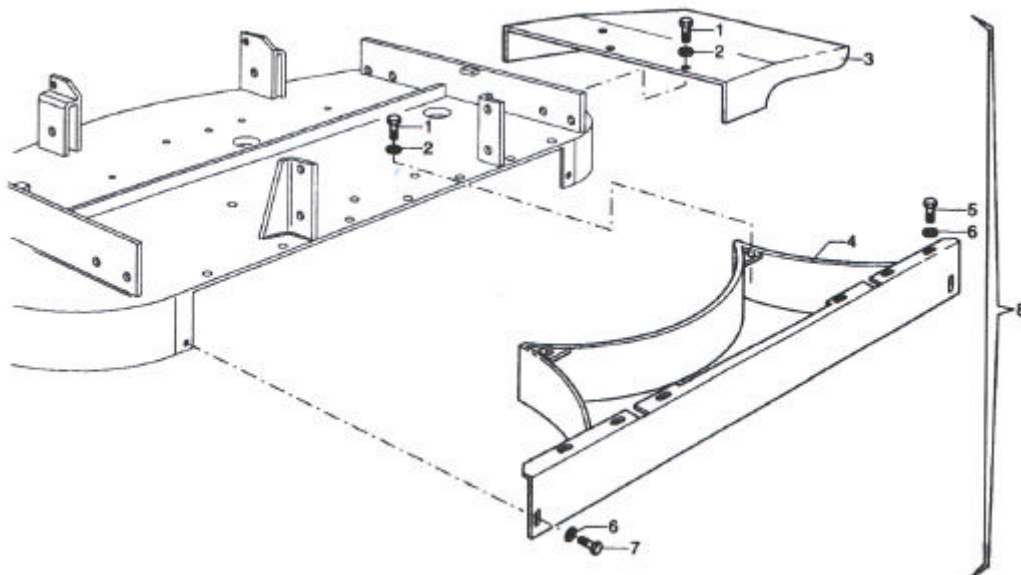
## REAR DISCHARGE – MR150 & MR180



Item No	Description	Qty	MR150 Part No	MR180 Part No
1	Screw		60021600	60021600
2	Washer		61004900	61004900
3	Deflector	1	40233600	40233700
4	Nut	3	62010400	62010400
5	Gripping	1	40233300	40233400

Item No	Description	Qty	MR150 Part No	MR180 Part No
6	Conveyor	1	39260500	39260600
7	Screw	1	60015700	60015700
8	Pin	1	31078400	31078500
9	Chain		68086000	68086000
10	Complete Kit		45113100	45113200

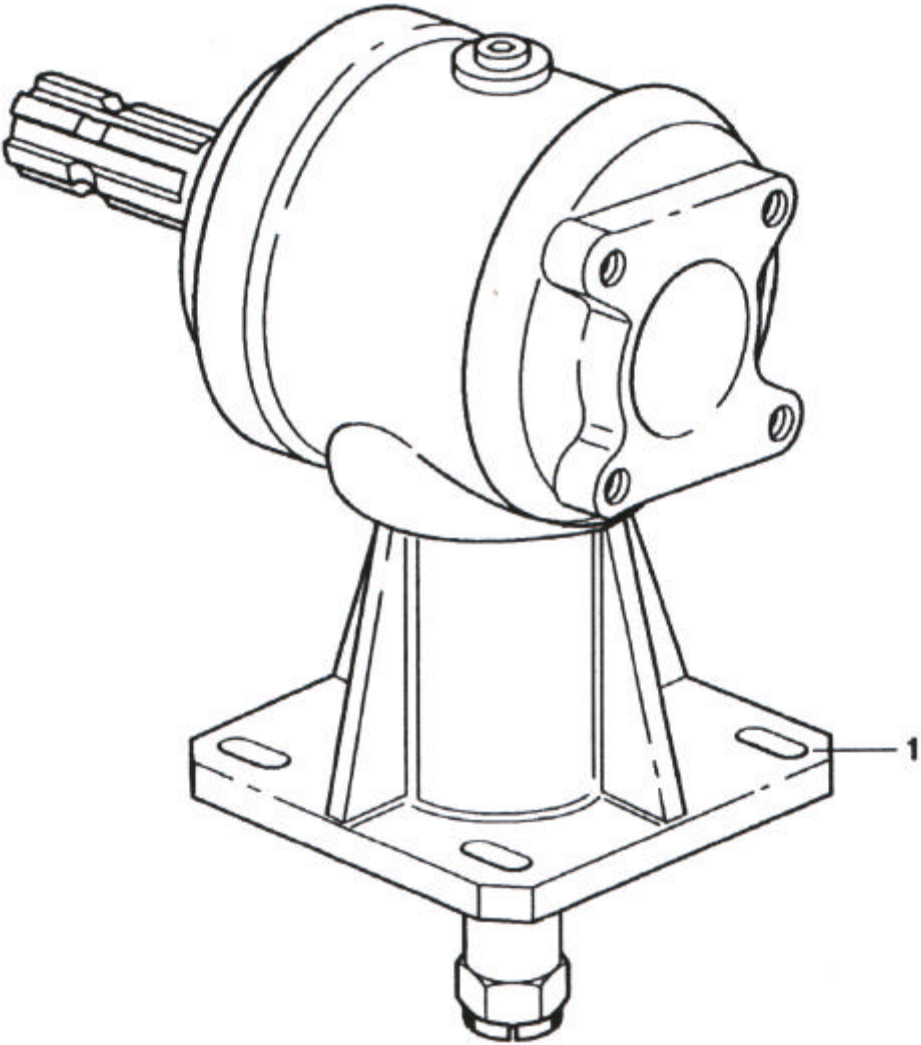
## SIDE DISCHARGE – MR150 & MR180



Item No	Description	Qty	MR150 Part No	MR180 Part No
1	Screw	6	60021600	60021600
2	Washer	6	61004900	61004900
3	Conveyor	1	39259900	39260000
4	Gripping	1	40233000	40233100

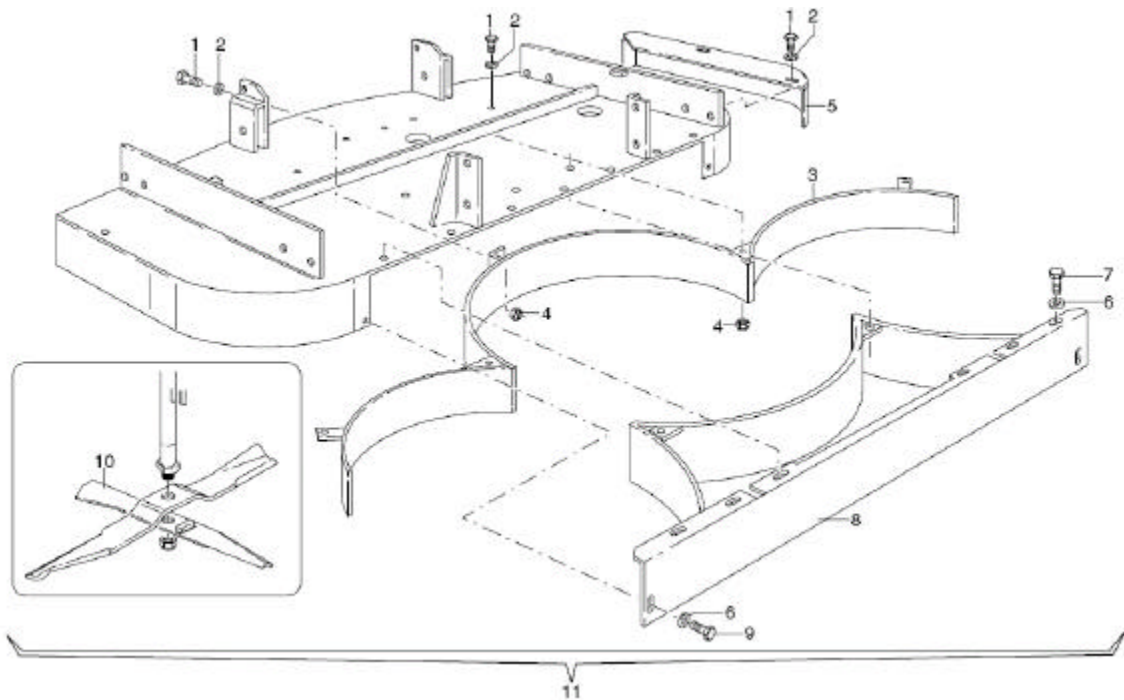
Item No	Description	Qty	MR150 Part No	MR180 Part No
5	Screw	6	60021600	60021600
6	Washer	8	61004900	61004900
7	Screw	2	60017900	60017900
8	Complete Kit		45112800	45112900

**GEARBOX – MR150, MR180 & MR235**



Item No	Description	Qty	MR150 Part No	MR180 Part No	MR235 Part No
1	Complete Gearbox	1	46035200	46035200	46035200

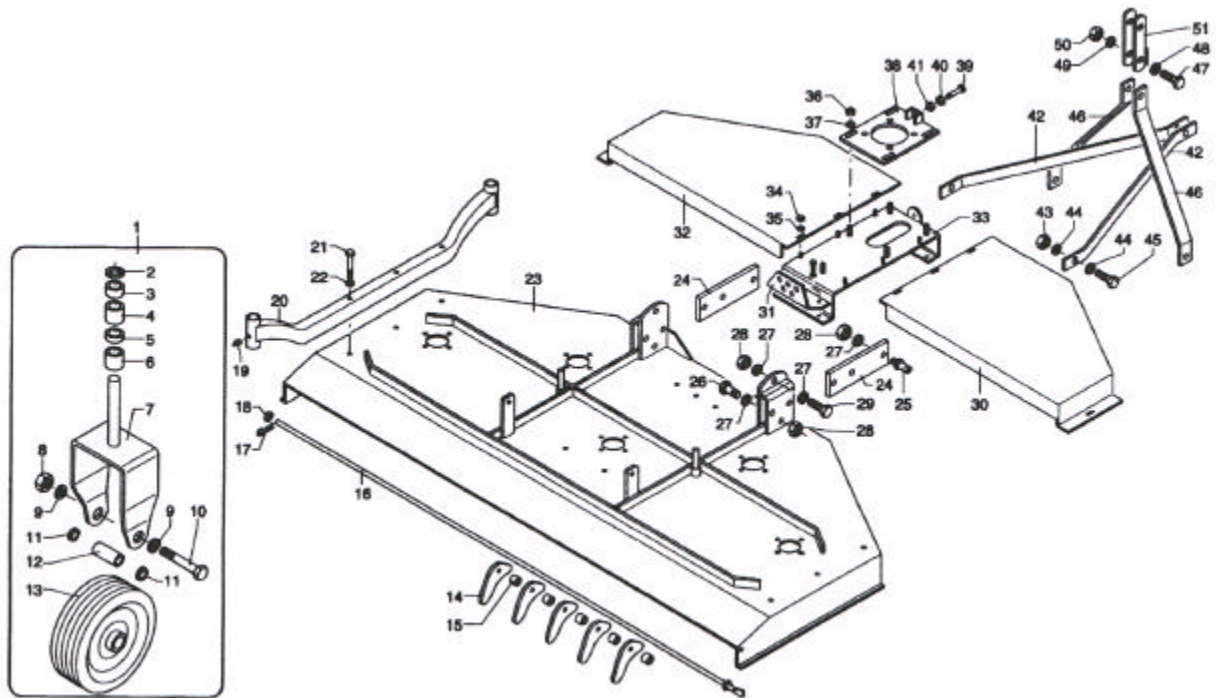
## MULCHING VERSION – MR150 & MR180



Item No	Description	Qty	MR150 Part No	MR180 Part No	Item No	Description	Qty	MR150 Part No	MR180 Part No
1	Screw	3	60021600	60021600	7	Screw	6	60021600	60021600
2	Washer	3	61004900	61004900	8	Gripping	1	40233000	40233100
3	Deflector	1	40233600	40233700	9	Screw	2	60017900	60017900
4	Nut	3	62010400	62010400	10	Mulching Blade	3	12018400	12018400
5	Gripping	1	40233300	40233400	11	MULCHING KIT		45114900	45115000
6	Washer	8	61004900	61004900					



# KIT FOR FRAME – MR235

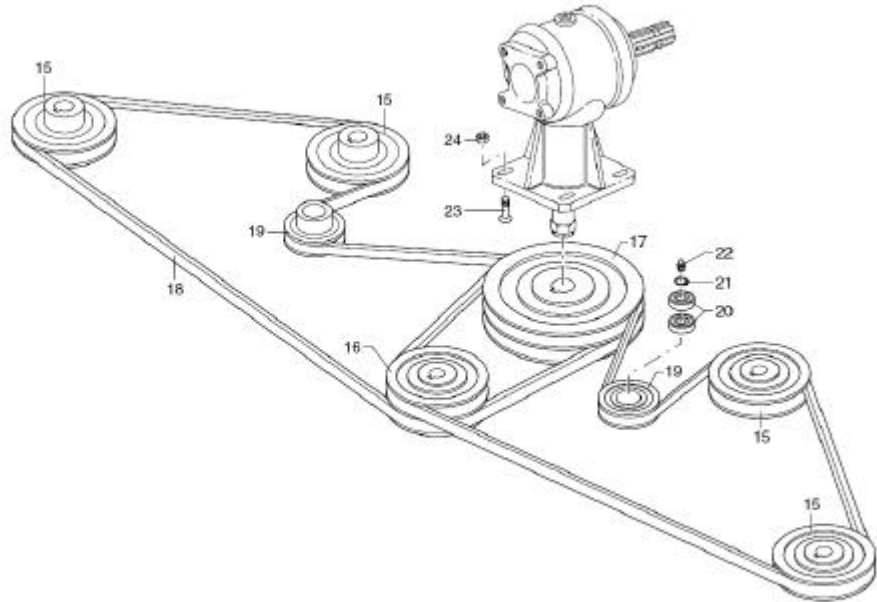
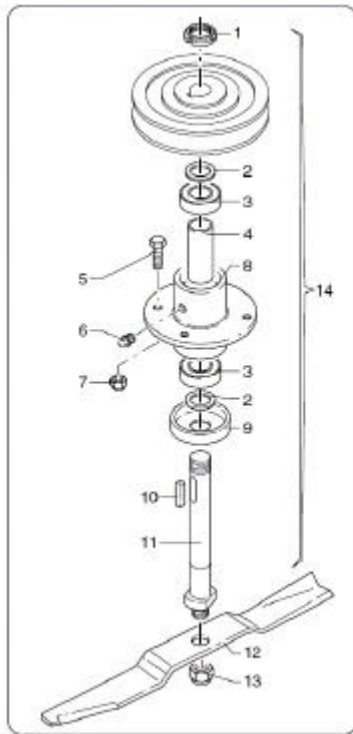


Item No	Description	Qty	MRP235 Part No
1	Wheel Assembly		45142800
2	Spacer	1	32187200
3	Spacer	1	32174600
4	Spacer	1	32174700
5	Spacer	1	32174900
6	Spacer	1	32175000
7	Yoke	1	68099000
8	Nut	1	62010600
9	Washer	2	61005000
10	Screw	1	60027500
11	Spacer	2	32174700
12	Spacer	1	32187300
13	Wheel	1	68087600
14	Disc		68099100
15	Spacer		68099200
16	Rod	1	31091800
17	Cotter Pin	1	64000900
18	Washer	2	61005000
19	Grease Fitting	4	64000200
20	Bracket	2	40278900
21	Screw	6	60030200
22	Washer	6	61004400
23	Frame	1	41118200
24	Bracket	2	30201200
25	Pin	2	68062500
26	Screw	2	60041600

Item No	Description	Qty	MRP235 Part No
27	Washer	8	61006100
28	Nut	8	62011100
29	Screw	2	60035000
30	Cover (RH)	1	39292100
31	Support	1	30201300
32	Cover (LH)	1	39292200
33	Support	1	40279000
34	Nut	6	62010200
35	Washer	6	61004700
36	Nut	4	62010400
37	Washer	4	61004900
38	Plate	1	40279100
39	Screw	1	60030200
40	Washer	1	61004900
41	Nut	1	62007000
42	Tierod	1	30201400
43	Nut	1	62010600
44	Washer	2	61005000
45	Screw	2	60021200
46	Tierod	2	30201500
47	Screw	1	60030500
48	Washer	2	61005000
49	Bushing	2	32187400
50	Nut	1	62010600
51	Attachment	1	40279200



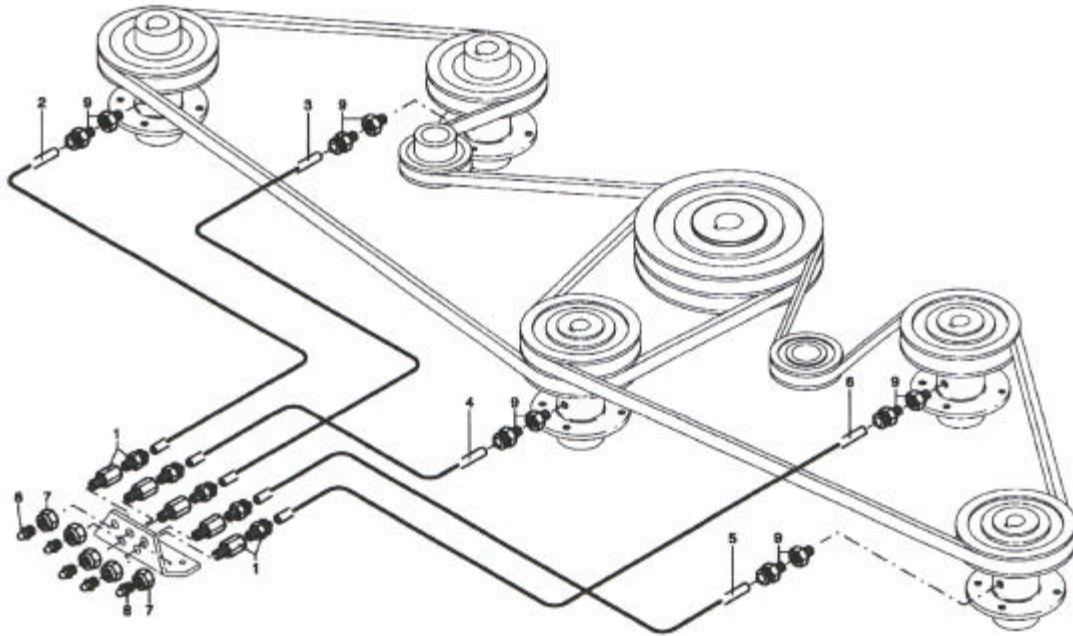
## TRANSMISSION ROTORS – MR235



Item No	Description	Qty	MRP235 Part No
1	Ring Nut	10	62001200
2	Spacer	5	68028400
3	Bearing	10	67016600
4	Spacer	5	32187500
5	Screw	20	60021300
6	Grease Fitting	5	64001800
7	Nut	20	62010400
8	Support	5	40279300
9	Guard	5	39292300
10	Key	5	65002900
11	Shaft	5	31091900
12	Blade	5	12017800

Item No	Description	Qty	MRP235 Part No
13	Nut	5	62011100
14	Spindle Assembly	5	45142000
15	Pulley	4	68099300
16	Pulley	1	68099400
17	Pulley	1	68099500
18	Belt	2	68092300
19	Pulley	2	68099600
20	Bearing	4	67016600
21	Snap-ring	2	63002200
22	Grease Fitting	2	64000200
23	Screw	4	60033200
24	Nut	4	62011000

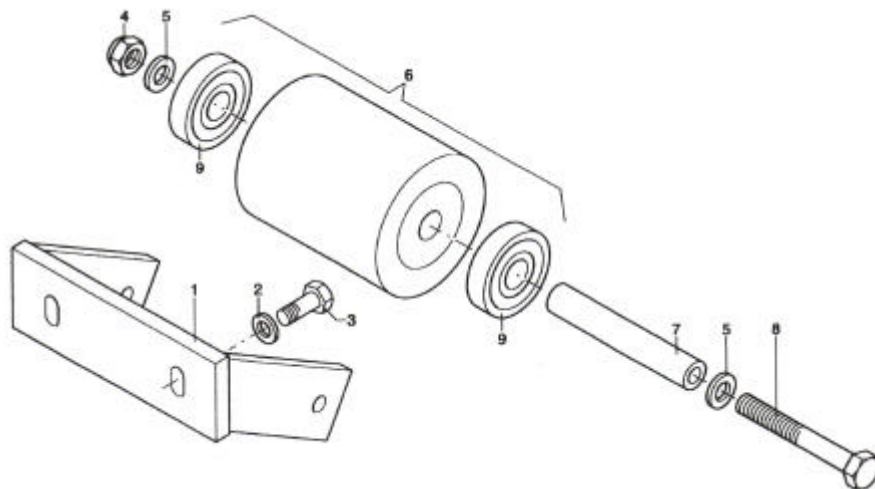
## GREASE EXTENSIONS - MR235



Item No	Description	Qty	MRP235 Part No
1	Connection	10	68096400
2	Tube	1	68100100
3	Tube	1	68100200
4	Tube	1	68100300
5	Tube	1	68100400

Item No	Description	Qty	MRP235 Part No
6	Tube	1	68100500
7	Sleeve	5	68096300
8	Grease Fitting	5	64001800
9	Connection	5	68101200

## ANTI-SCALPING ROLLER – MR235



Item No	Description	Qty	MRP235 Part No
1	Support	1	40279400
2	Washer	2	61004900
3	Screw	2	60021300
4	Nut	1	62010600
5	Washer	2	61005000

Item No	Description	Qty	MRP235 Part No
6	Roller	1	45151300
7	Spacer	1	32187600
8	Screw	1	60041700
9	Bearing	2	67008300

## **TROUBLESHOOTING**

<b>Fault</b>	<b>Cause</b>	<b>Remedy</b>
Leaves a streak of uncut or partially cut grass	Blades dull or bent  Carrier RPM too low  Field conditions are so wet that the tractor tire is pushing grass into mud  Ground speed too fast  Grass is down from previous weather conditions  Possible build-up materials under mower	Replace blades  Use correct PTO speed  Too wet to mow. Stop operation and wait until it is drier  Reduce ground speed by shifting to a lower gear  Mow in only one direction  Clean mower
Material discharges from mower unevenly; bunches of material along with swath	Material too high and too much material  Grass wet	Reduce ground speed but maintain 540rpm at tractor PTO or make two passes over material. Raise mower for the first pass and lower to desired height for the second and cut a 90 degree angle to first pass  Allow grass to dry before mowing. Slow ground speed of tractor but keep engine running at full PTO rpm. Cutting lower will help
Gearbox overheating	Low on lubricant  Improper type lubricant  Excessive trash build-up around gearbox	Fill to proper level  Replace with proper lubricant  Remove trash
Blade is scalping ground	Mower too low  Field is ridged  Field is too wet	Raise mower-reset wheels  Cut field at a different angle  Stop and wait until it is dried
Mower will not cut. (Shear bolt drive only)	Shear bolt sheared  Slipped belts  Broken belts	Install new shear bolt  Stretch the belts  Replace the belts
PTO contacts mower front frame when raised	Raising mower too high or incorrect adjustment of tractor top link	Adjust top link or tractor lift stops (See attachments instructions)
Blades wear too fast	Cutting in sandy conditions  Cutting in rocky conditions	Increase cutting height  Increase cutting height
Blades wear too fast	Blades hitting ground	Increase cutting height

Mower seems to require excessive power	<p>Advancing into grass too rapidly</p> <p>Hitting ground</p> <p>Worn or dull blades</p> <p>Tractor not large enough</p>	<p>Reduce forward travel speed</p> <p>Raise mower and reset wheels</p> <p>Sharpen or replace blades</p> <p>Use larger horsepower tractor</p>
Excessive vibration	<p>Check gearbox bolts</p> <p>Check for loose nuts on blades</p> <p>Blade broken</p> <p>New blade or bolts matched with worn blade or bolts</p> <p>Drivelines not phased correctly. Implement and tractor yokes must be in line</p>	<p>Tighten if loose</p> <p>Tighten if loose</p> <p>Replace blades, in set</p> <p>Replace blades or bolts in sets</p> <p>Phase the driveline. Replace if necessary</p>
Gearbox noisy	<p>Worn bearing</p> <p>Low oil in gearbox</p>	<p>Replace bearings</p> <p>Check level and add oil</p>
Gearbox leaking	<p>Damaged oil seal</p> <p>Bent shaft</p> <p>Shaft rough in oil seal area</p> <p>Oil seal installed incorrectly</p> <p>Oil seal not sealing in the housing</p> <p>Oil level too high</p> <p>Hole in gearbox</p> <p>Gasket damaged</p> <p>Bolts loose</p>	<p>Replace seal</p> <p>Replace oil seal and shaft</p> <p>Replace or repair shaft</p> <p>Replace seal</p> <p>Replace seal or use a sealant on outside diameter of seal</p> <p>Drain oil to proper level</p> <p>Replace the gearbox</p> <p>Replace gasket</p> <p>Tighten bolts</p>

## **WARRANTY PROCEDURE**

### **Steps to take in the event of machine failure**

#### ***Dealer:***

- The warranty claim will be completed by the Major dealer and will be submitted either to head office or to the Major area representative. Any parts replaced under warranty must be tagged and retained until claim is resolved. When ordering replacement spare parts please notify the Major Stores person that this is a warranty claim.
- The Major dealer will sign off on the claim and submit it to Major for consideration.
- The Technical Service Department at Major will study the claim and may request parts to be returned for examination. Major will notify their conclusions to the dealer service person from whom the claim was received.
- Any replacement parts ordered for the machine must be flagged as such when contacting Major. The delivery note and invoice will be flagged with "Warranty Pending" and will be invoiced as normal.
- A warranty claim form will be sent by Major to the dealer for completion. Only when the completed warranty claim form has been received by Major will the claim be resolved.
- Dealers must notify the Major Representative within 10 days of breakdown and all warranty claims are to be settled within 90 days of breakdown notification.

#### ***Customer:***

Should a Major machine fail due to a defect in material and/or workmanship, the owner should make a warranty claim as follows:

- The machine must be taken to the dealer from where it was purchased or to an authorised Major dealer.
- The owner must present proof of warranty registration.
- The warranty claim will be completed by your Major dealer and will be submitted either to head office or to their Major area representative. Attention: Service Manager: Any parts replaced under warranty must be tagged and retained until claim is resolved.
- The Major dealer will sign off on the claim and submit it to Major for consideration.
- The Technical Service Department at Major will study the claim and may request parts to be returned for examination. Major will notify their conclusions to the dealer service person from whom the claim was received.
- The decision by the Quality/Service department at Major to approve or reject a Warranty claim is final and binding.
- 

NOTE: To process a warranty claim, it is necessary to quote the Model & Serial Number which are printed on the Major Serial Plate – see owners manual

This company warrants its products to be free from defects under the following terms and conditions:

#### ***1. Length***

All new Major products come with a one year limited warranty against defects in materials and workmanship from the original date of purchase from an authorised dealer. Products that have been repaired/replaced will be under warranty for the remainder of the original warranty period or thirty days, whichever is longer.

#### ***2. Transferability***

The warranty is non-transferable and is only valid for the original owner of the product.

#### ***3. Coverage***

All Major products come with a limited warranty for the period of one year, unless otherwise stated. The warranty solely covers parts and labour of Major products. Major are not liable for products that have been damaged due to abuse or negligence, nor are we liable for incidental or consequential damages. Any normal wear and tear that occurs is not covered under Major's warranty. Consumables such as blades, belts and PTO shafts are not covered under Major's warranty.

The following will result in the warranty being voided

- any product where the serial number has been defaced, modified or removed
- Damage or failure due to abuse, neglect, usage outside of intended purpose & failure to read instructions.
- Unauthorised repairs
- Any non-superficial repairs
- Failure to supply serial number details and/or proof of purchase

The following are not covered under Major's warranty:

- items purchased second hand
- any problem pertaining to cosmetics, unless pre-existing
- failure to determine if the product is right for your intended purposes
- Any incidental or consequential damages that occur to products not made by Major

#### ***4. Exclusion of Damages***

Major reserves the right to either repair or replace the defective product. Major shall not be held liable to the purchase or any third party for any incidental or consequential damages, including, but not limited to, damages resulting from interruption of service and loss of business. Major is solely responsible for products manufactured by Major and offers no warranties, expressed or implied, for any other products.





**HEAD OFFICE**  
**Major Equipment Intl Ltd**  
Ballyhaunis, Co Mayo  
Ireland  
Tel: 094 9630572

**UK OFFICE**  
**Major Equipment Ltd**  
Major Ind. Estate, Heysham,  
Lancs, LA3 3JJ, UK  
Tel: 01524 850501

**NL & GERMANY OFFICE**  
**Major Equipment Intl Ltd**  
Postbus 29, NL-7700 AA  
Dedemsvaart, Nederland  
Tel: + 31 (0) 6389 19585