

Operator Manual & Parts List

MAJOR
EAGLE WING TOPPER



Head Office

Major Equipment Intl Ltd
Ballyhaunis,
Co. Mayo,
Ireland

Tel.: 09496 30572
Fax: 09496 30788

UK Office

Major Equipment Ltd.
Major Industrial Estate.
Middleton Rd
Heysham
Lancs.
LA3 3JJ

Tel.: 01524 850 501
Fax: 01524 850 502

NL & GERMANY OFFICE

Major Equipment Intl Ltd
Postbus 29
NL-7700 AA
Dedemsvaart
Nederland

Tel: + 31 (0) 6389 19585

Web: www.major-equipment.com

Disclaimer

While every effort has been made in the production of this manual to ensure that the information contained herein is full and correct, Major assumes no responsibility for errors or omissions.

Major reserves the right to modify the machinery and the technical data contained within the manual without prior notice.

Further to this, Major assumes no liability for any damages which may result from the use of the information contained within this manual.

CONTENTS

INTRODUCTION	2
WARRANTY	2
SAFETY INFORMATION	3
KEY TO MAIN PARTS	6
OPERATION INSTRUCTIONS	
Regulations for use of transmission	7
Starting regulations	8
Solenoid Control Box Mounting	9
Transport	9
Operating the machine	10
MAINTENANCE & SERVICING	11
SPECIFICATIONS	14
TROUBLESHOOTING	14
PARTS LISTING	
Overview	16
Drawbar	17
Body	18
Wing	20
Main Splitter Gearbox	22
Rotor Gearbox	23
Slip Clutch set-up Dimensions	24
Blade Assembly	25
Wiring Diagram	26

INTRODUCTION

The Major 490 Eagle Wing that you have purchased is the result of costly development and extensive field-testing. It is an engineering product, backed by a dealer distribution network designed to offer you an efficient after sales service.

Please follow the instructions given in this manual. You will then obtain the best results from your new machine at the lowest cost.

Lack of maintenance will induce excessive power consumption. This waste of power will not only induce a heavy load on the machine, but will also cause breakdowns and expensive repairs.

An exact description of the machine model and year of manufacture will ensure quick and pertinent answers from our Technical Assistance Service. Always state the machine model when contacting our offices or your nearest dealer.

We suggest you write the data pertaining to your machine in the following space.

Year of manufacture		Model	
Serial Number		Date of purchase	

IRELAND USERS

Health, Safety and Welfare at Work Act (1989).

UNITED KINGDOM USERS

Health and Safety at work Act (1974)

Both Acts require that all operators must be given instruction on the safe operation, maintenance and repair of all machinery. This booklet forms part of the instruction for the **Major 490 Eagle Wing** and must be read by all operators and repairers before operating the machine. The supplier must also instruct the customer and user regarding the operation, adjustment and explain all necessary safety precautions when maintaining, operating or repairing the machine.

WARRANTY

The **Major 490 Eagle Wing** is guaranteed for 1 season. Gearboxes are guaranteed for two years provided they have been properly maintained and not subject to misuse or abuse. Misuse specifically includes but is not limited to, maintaining proper oil levels of the correct lubricant, and adjusting slip clutches to provide proper protection to gearbox components. No warranty is given where the machine is being used as a hire machine.

Warranty is against faulty workmanship or parts, with the exception of components not of Major's manufacture or design, i.e. hydraulic components, universally jointed shafts, blades and tyres, etc., which are subject to the original manufacturers conditions.

No warranty is considered unless the faulty parts have been returned.

All replacement parts will be supplied on a chargeable basis until warranty has been accepted.

Major cannot accept liability for injury or damage caused by our machines resulting from operational negligence.

Major reserve the right to withdraw warranty if:

Non-original parts have been fitted.

The machine is not maintained correctly

The machine is overloaded, or operated incorrectly

The machine is used for purposes other than those for which it has been designed

Major and importers do not accept liability if non-Major parts have been fitted.

Please return warranty card provided with this manual to register your Warranty.

Please retain receipt as proof of purchase

SAFETY INFORMATION

The **Major 490 Eagle Wing Topper** comes equipped with all safety labels in place. They are intended to help you operate your machine safely.

1. Read and follow the safety label directions.
2. Keep safety labels clean and legible.
3. Replace damaged or missing safety labels.

Read the Manual.

Thoroughly read and understand the manual.

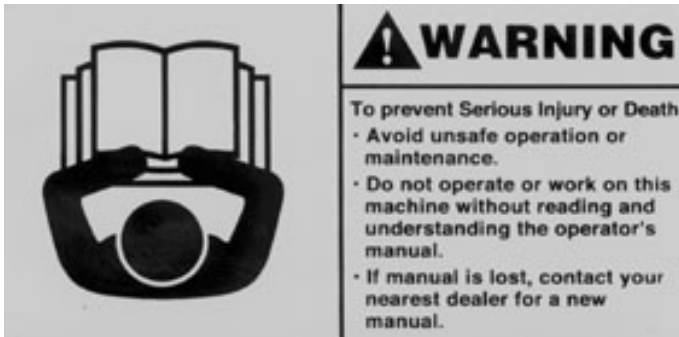

High Oil Pressure Hazard

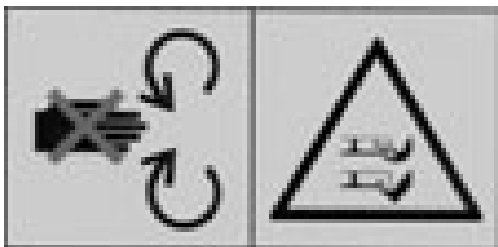

Rotating Blade Hazard.

Keep clear from blades while machine



Driveline Entanglement Hazard.

Keep clear of PTO drives.

**Fold PTO stand down
before removing transport
pin, otherwise PTO shaft
will be damaged!**

Damage Warning.

Store PTO stand to avoid damage to PTO shaft

**CHECK
WHEEL NUTS
DAILY**

**TYRE PRESSURE
2 BAR**

Maintenance Warning.

Keep wheel nuts tight.
Check tyre pressure

**MAX SPEED
30 KM/H**

Speed Warning

Max speed for towing the machine

! ATTENTION!! !
**CHECK TIGHTNESS OF
TRANSMISSION BOLTS
AT EVERY SERVICE.**

Maintenance Warning.

Keep transmission bolts tight.

**MAX. P.T.O.
INPUT
540 R.P.M.**
0003

Speed Warning

Max P.T.O speed for the machine

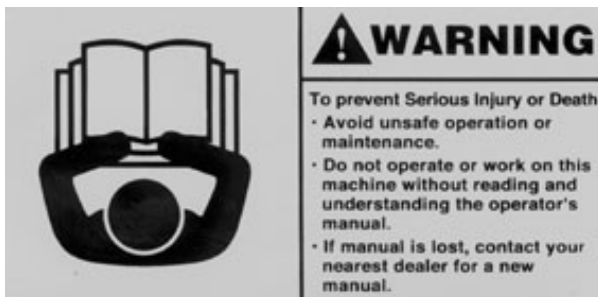

Read the Manual.

Thoroughly read and understand the manual.



Moving Parts Hazard.

Keep clear while operating wings.

GENERAL SAFETY REGULATIONS WORK STATION

The **Major 490 Eagle Wing** must only be used for cutting grass. Moreover, it must only be used with a suitable tractor (see specifications on page 12) and driven by an adequate driveline by the tractor PTO.

All other use is strictly prohibited.

Users should become thoroughly familiar with the contents of this manual before using, servicing and mounting the implement to the tractor and all other pertinent operations.

Never wear jewellery, loose clothing such as ties, scarves, belts, unbuttoned jackets or dungarees with open zips, which could become caught up, in moving parts. Always wear approved garments complying with accident prevention provisions such as non-slip shoes, earmuffs, goggles and gauntlets. Wear a jacket with reflecting stickers if the implement is used near public highways.

Consult your retailer, the Labour Health Service or your nearest equivalent authority for information about the current safety provisions and specific regulations to comply with in order to ensure personal safety

The operator must remain seated while working the machine. Always ensure that the PTO has been turned off and the parking brake applied before leaving the tractor cab.



WARNING!!



Never have hydraulic hoses inside the tractor cab.

Never operate tractor hydraulics with the tractor switched off.

**THE CORRECT ROTATION SPEED OF
THE TRACTOR PTO INPUT IS 1000 RPM**

KEY TO MAIN PARTS

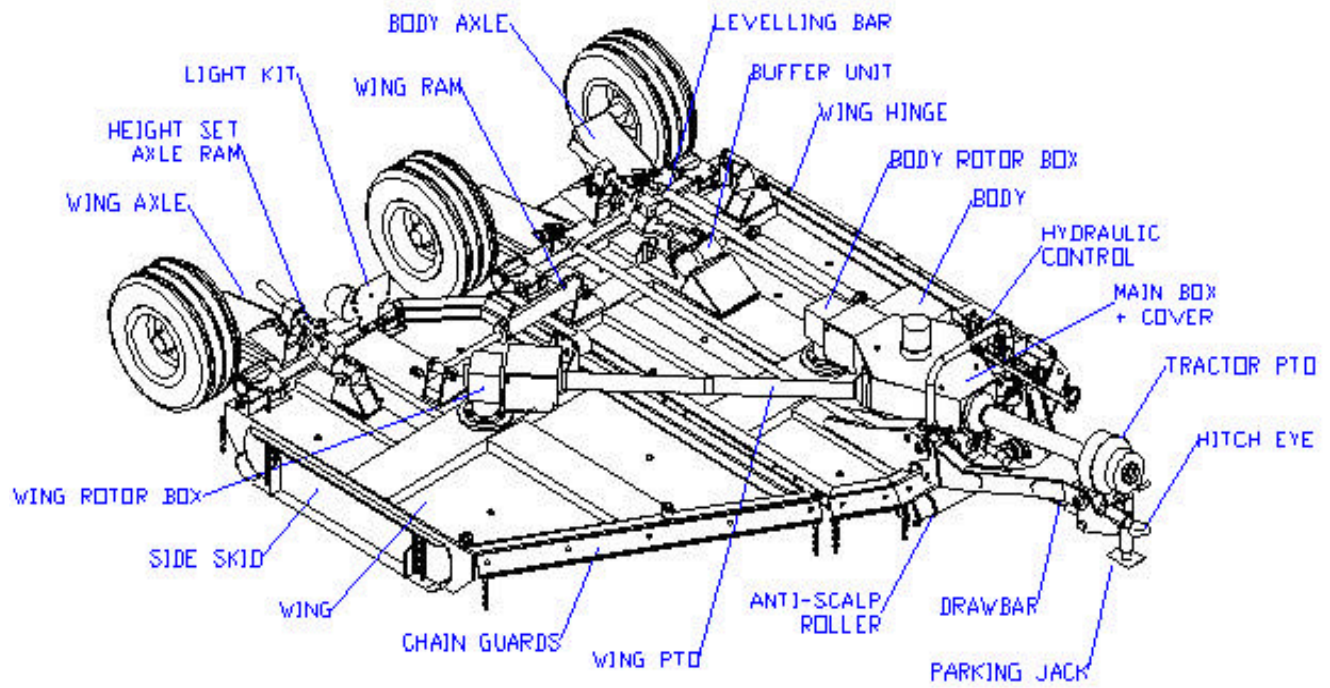

OPERATION INSTRUCTIONS

REGULATIONS IN THE USE OF THE TRANSMISSION

The transmission to the gearboxes is protected throughout the machine by both guarded PTO shafts and bolt down covers. All guarding should be kept efficient and in good condition. If the condition is poor, the guarding should be renewed before the implement is used



Unless it is correctly protected, the transmission could cause death since it can catch on parts of the body or clothing.

Ensure retaining chains are correctly anchored on all PTO shafts, preventing them from turning. Ensure drive-line can turn easily within the shield.

Keep spline grooves clean and greased so that PTO shaft can connect easily. Besides being described in this manual, the method by which the PTO shaft is connected to the tractor must be checked out with the instructions in the tractor manufacturer's manual.

PTO SHAFT LENGTH

The tractor PTO shaft length may be altered to suit the individual tractor model. When the machine is in operation, the PTO shaft should have a minimum 1/3 engagement as shown in the diagrams below.

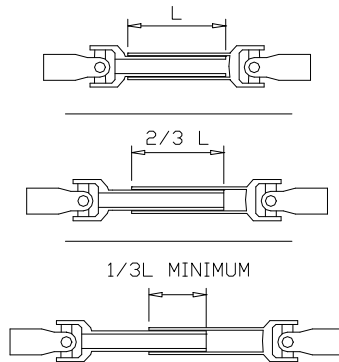

After the Major 490 Eagle Wing has been hitched to the tractor, it should be checked in various positions that the driveline is the correct length. If the PTO is too short and tends to slip out of place, it must be replaced with a longer one.

If the PTO shaft is too long, it should be shortened in the following way:

1. Set the machine at a minimum distance from the tractor, then brake the tractor and switch off the engine.
2. Separate the two halves of the PTO. Insert the female part into the tractor PTO and the male part into the **Major 490 Eagle Wing** PTO, checking that the position is correct by means of the fixing pins.

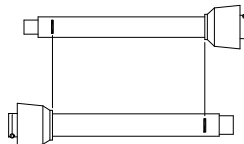

3. near the two halves of the PTO together, keeping them parallel.
4. using a felt tip pen, match mark the place where the two halves must be shortened as shown.
5. first cut shield "1" and use part "2" as a reference to cut the splined shaft.
6. proceed in the same way for the second half.

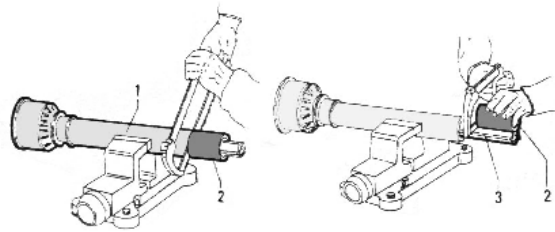

7. Trim and chamfer the two cut ends of the PTO and clean off all swarf and shavings.
8. Grease the two profiles and join the two halves of the PTO together again.
9. Mount the PTO shaft and check that its length is correct as before. The shaft must not reach the end of the tube or project from this.

Ensure the PTO does not bottom when turning, or when tractor front axle is raised or lowered while climbing or descending a sharp incline.

STARTING REGULATIONS

Always check that any imminently dangerous conditions have been eliminated before using the machine. Ensure all guarding is present & the operator is fully aware of the operations of the machine.



WARNING!!

Always disengage PTO, Switch off tractor engine and engage the parking brake before making adjustment to the machine.

HITCHING TO THE TRACTOR

1. Reverse the tractor, connect the hitch & secure in position with correct size drawbar pin.
2. Ensure the tractor parking brake is applied.
3. Adjust the level of the drawbar until the main body is level.
4. Connect the hydraulic connections to the tractor.
5. Mount the solenoid control box in tractor cab. (Option)
6. Fit the PTO shaft & secure the PTO cover chains.
7. Raise the parking jack, remove from drawbar, and remount on wing.

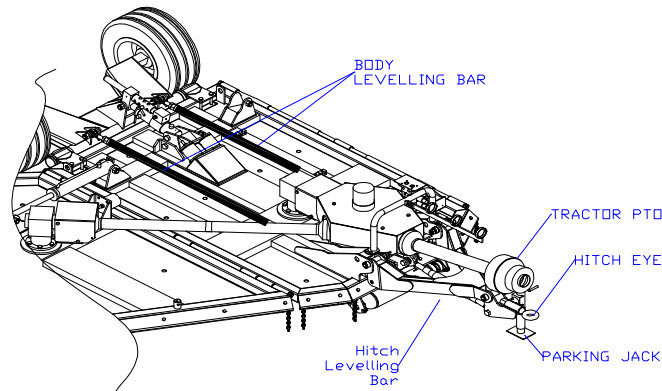



WARNING!!



Always ensure the pins lock the PTO shaft yoke ends onto the splined shafts on both the tractor and the implement. An unlocked shaft could slip out of position, causing notable mechanical damage and serious injury to both operator and bystanders.

SOLENOID CONTROL BOX MOUNTING (OPTION)

1. The solenoid control box should be mounted inside the tractor cab on a suitably clean, smooth surface to ensure the suction pad 'D' will not slip.
2. Ensure all switches are in the 'Stop' position.
3. Plug the connector into a 12v DC supply.

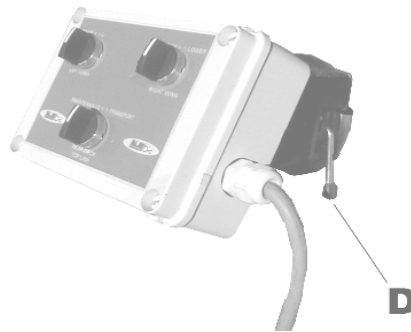

CAUTION!!



Contact your nearest dealer or a specialised retail outlet if the PTO must be replaced with a longer one, since this must belong to the same power category and possess the same characteristics.

An unsuitable PTO could easily break.

TRANSPORT AND MOWING



WARNING!!



Check the local Highway Code regulations before driving the tractor on public highways with a towed implement. Check the reflectors, hazard flashers and/or projecting load indicators are installed when required and efficient. These indicators must be installed correctly and easily seen by the drivers of other vehicles.

Bystanders must not be allowed to lean against or climb onto the machine during transport or while working. Do not allow bystanders to ride on the machine.

ROAD TRANSPORT

Check machine is hitched to the tractor as described. Ensure the tractor parking brake is applied. Attach hydraulic connections (check tractor manual for correct hydraulic layout when using solenoid option i.e. OPEN or CLOSED circuits). The 490 Eagle Wing is factory set for 'OPEN' hydraulic circuits. (Ref page 9).

Lift the two wings by hydraulic control & lock in position using the cargo strap provided to fully secure wings.

Lift the rear axle by hydraulic control and lock via the shear pins and height set tube supplied.
Retract the wing axles by hydraulic control and lock via the shear pins and height set tube supplied.
Attach 12v lighting connections.



WARNING!!



Maximum transport speed for the implement is 30km/h.
DO NOT EXCEED

OPERATING THE MACHINE

The **Major 490 Eagle Wing** is designed to operate at a max 1000 rpm. Always operate on level ground when hitching / unhitching the implement. This will prevent dangerous movement.

Never allow anyone to stand between the tractor and the 490 Eagle Wing.

Ensure the machine is hitched correctly to the tractor as previously described.

Set cut height via the shear pins and height set tubes on axle rams.

Unlock cargo strap supporting the wings

Lower cutting decks to the ground.

Start up the tractor PTO at a low RPM.

Build up to operating speed, select a suitable forward gear & proceed to cut grass.

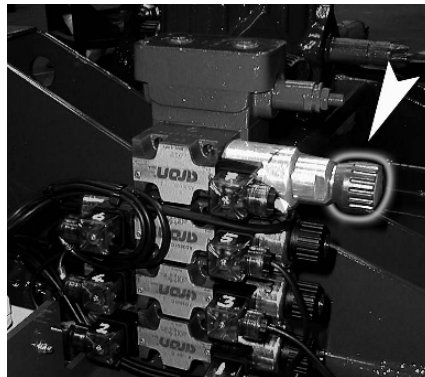

Solenoid option Control

NOTE: When using Solenoid control option the machine is factory set to operate with 'OPEN center' hydraulic systems. When connecting to tractors with 'CLOSED center' hydraulics, the Pilot valve spool knob (shown above) must be closed (screwed 'IN').
(Screw 'OUT' for Open Center systems)

MAINTENANCE

FOREWORD

MAINTENANCE MUST BE CARRIED OUT BY QUALIFIED PERSONNEL.

The **Major 490 Eagle Wing** must always be disconnected from the tractor before any cleaning, lubricating and servicing operations can be carried out. Ensure that the Wing decks are locked Up while performing maintenance.

If emergency operations are required whilst the machine is connected to the tractor, switch off the engine, engage the parking brake and disengage the PTO.

Good, regular maintenance and correct use are essential if the **Major 490 Eagle Wing** is to remain safe and long lasting.



Always disengage PTO, Switch off tractor engine and engage the parking brake before making adjustment to the machine.



When maintaining the machine with one or both wings in the raised position, ensure the drives to the wings are disengaged & the cargo strap lock is secure.



Never place limbs under the machine while rotors are turning. Rotors can remain turning for up to 1 minute after disengaging PTO.

DO NOT USE HIGH PRESSURE WATER AROUND THE SOLENOID AS THIS MAY DAMAGE THE SOLENOID

INSPECTIONS BEFORE USE.

With the wings lowered and the whole machine as level as possible, check the oil level in the Centre (splitter) gearbox. Top up as required with SAE EP90 gear oil through the oil filler plug indicated. The correct level is at the oil level plug indicated. Check the oil level in the rotor gearboxes and top up as required with SAE EP 90 gear oil through the oil filler plugs indicated. The correct level is at the oil level plug indicated.

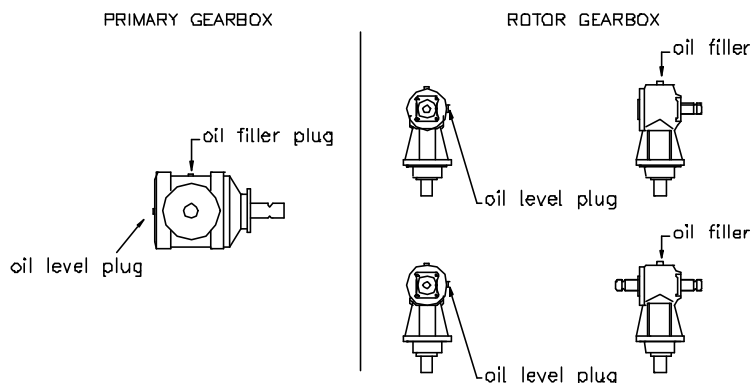

- Grease the PTO shaft universal joints, drive shaft bearing and roller bearings daily.
- Grease the drawbar bush, wing pivots.
- Re-sharpen old blades with a grindstone if necessary. Replace bent blades with new ones.
- Check the blade mounting bolts are tight.
- Ensure the gearbox shaft nuts are tight and retained in place by split pin.
- Check tightness of all nuts, bolts and retaining screws after the first and second hours of work.
- Ensure safety guards and flaps are in place at all times where fitted.
- Due to the corrosive nature of grass when cut, wash down the machine when finished mowing, especially when the machine is being stored for a long period of time.

MAINTENANCE SCHEDULE

Grease the following:

	Initially	8 Hours	16 Hours
PTO Shaft Yoke Ends (2)	?		?
Hitch Eye Pivot (1)	?		?
Drawbar Pivot (2)	?		?
PTO Shaft Yoke Ends (4)	?		?
Wing Hinge (2)	?		?
Wing Ram Pivots (4)	?	?	
Axle Ram Pivots (6)	?	?	
Wheel Bearing (4)	?	?	
Axle Mount Pivot (6)	?	?	
Buffer Mount Pivot (1)	?		?
Roller Bearings (2)	?		?

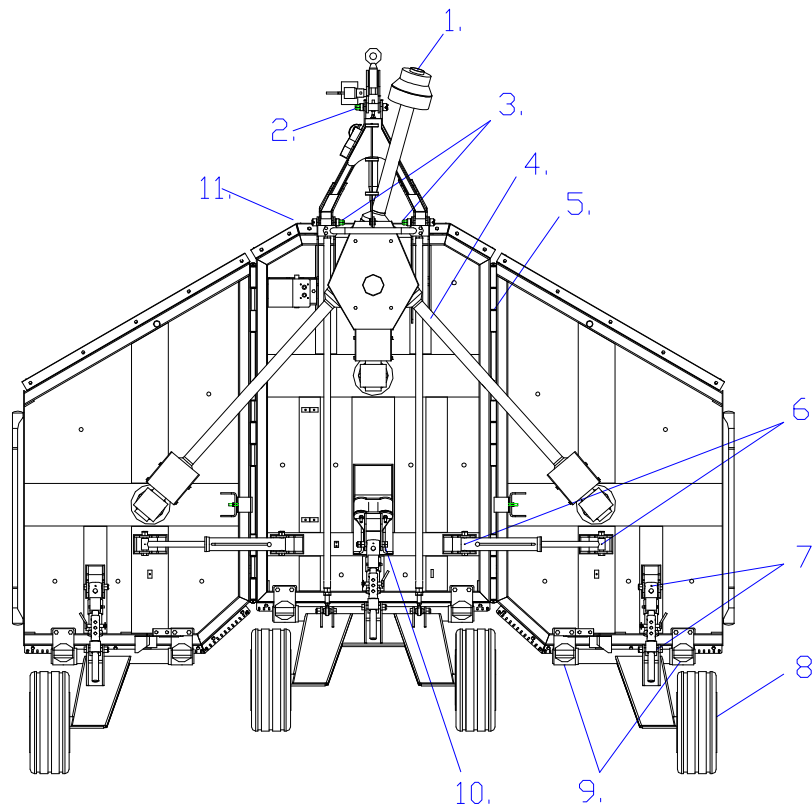

BLADE ROTATION

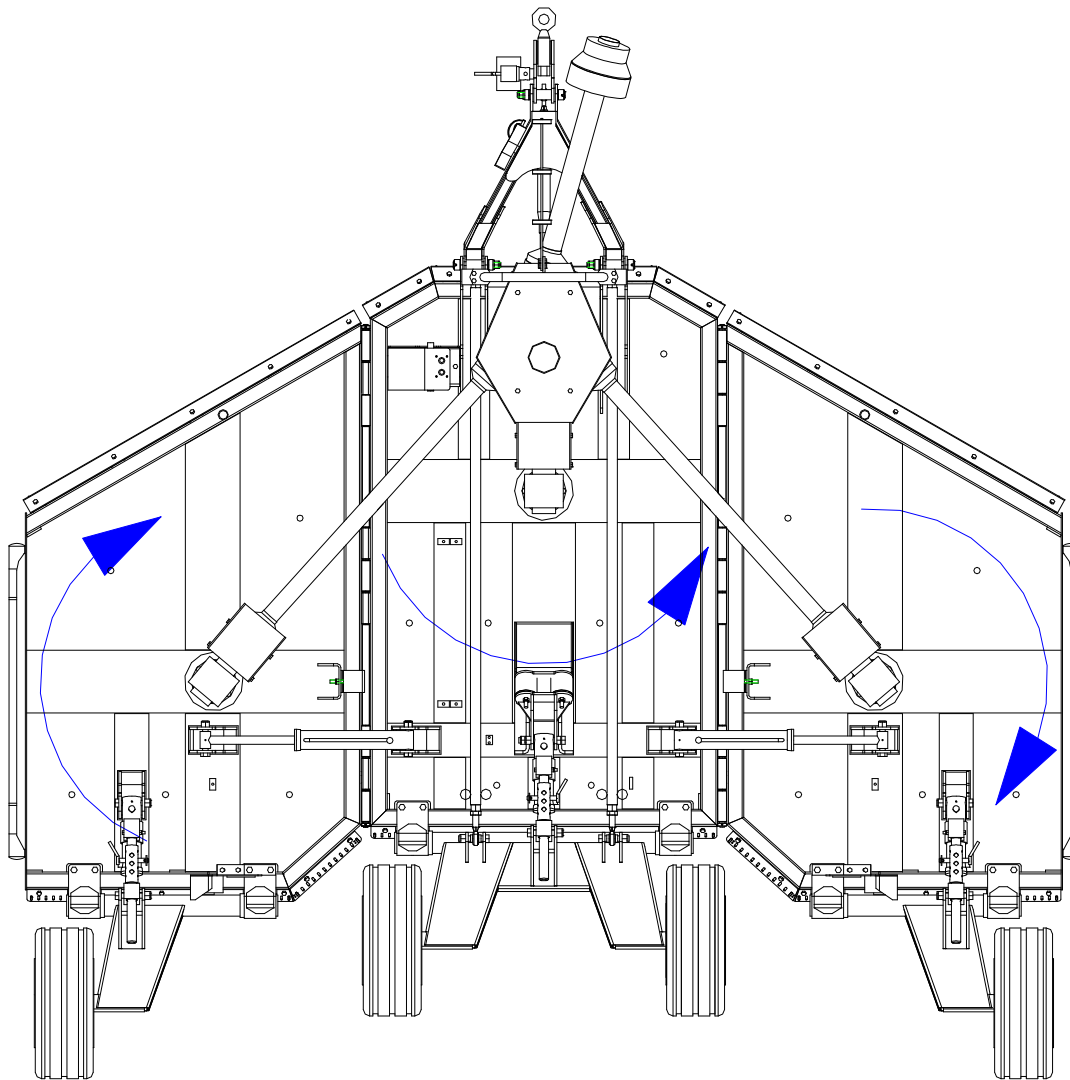

**ENSURE BLADE ROTATION IS
CORRECT AFTER SERVICING TRANSMISSION.**

All nuts and bolts in the transmission including PTO Shafts, Gearboxes & wheel nuts should be checked for tightness after mowing at the following intervals:

1st 50 acres,

1st 100 acres,

1st 250 acres and every 250 acres thereafter.

Lubricate moveable mechanical joints when required.

SPECIFICATIONS

SPECIFICATIONS	490 Eagle Wing
Length (Road Wheels)	4517mm (14' 10")
Overall Length (Wing Wheels)	4800mm (15' 9")
Cutting Width	4845mm (15' 11 ")
Overall Width	5088mm (16' 8 1/2")
Transport Width	2300mm (7' 6")
Transport Height	2255mm (7' 5")
Cutting Range	30 - 435mm (1 1/4" - 17")
Wing Float	20 deg Down / 90 deg Up (Transport)
No. of Blades	3 Rotors / 9 Blades
Blade Overlap	135mm (5 3/8")
Blade Tip Speed	89m/s (17580 ft/min)
Power Requirements	55 - 115 kW (70 - 150 HP)
Tyre Pressure	28 – 35 p.s.i
Gearbox Oil	EP 90 Gear oil
Lubrication grease	Multi-purpose grease
Weight	2700 kg (5950 lb)

TROUBLE SHOOTING

Fault	Cause	Remedy
Irregular Cut	Decks not levelled correctly Worn or broken blades. Axle height set tubes set at differing levels P.T.O speed too slow.	Level machine as described in manual Sharpen or replace blades Check position of shear pin on each axle ram. Check PTO rpm rate and adjust as necessary.
Noisy machine	Loose parts. Insufficient oil in gearbox. Wrong PTO rpm rate. Rotors out of balance. Bent P.T.O shaft.	Check all bolts are fully tightened. Check oil level and top up as necessary Check PTO rpm rate and adjust as necessary Replace bent or missing blades. Check output shaft on gearbox is not damaged Check driveline between gearboxes is aligned.
Excessive vibration.	Loose parts. Wrong PTO rpm rate.	Check all bolts are fully tightened Check PTO rpm rate and adjust as necessary. Check blades and replace if necessary
Machine will not cut grass.	Rotor PTO clutch slipping. Decks set too high	Check clutch spring tension and adjust as necessary. Adjust height set tubes for correct cut.

PARTS BOOK

Use only **MAJOR** spare parts for the best results.



SAFETY FIRST!

A moment's lack of attention can result in an accident, as can failure to observe certain elementary precautions. Do take time to ensure your safety and others are not put at risk.

Essential dos and don'ts.

- Don't allow any spilt oil or grease to remain on the floor - wipe it up straight away, before someone slips on it.
- Don't use ill-fitting spanners or other tools, which may slip and cause injury.
- Don't attempt to lift a heavy component, which may be beyond your capacity - get assistance.
- Don't rush finish a job, or risks by taking shortcuts.
- Do wear eye protection when using power tools such as drills, grinders, etc.
- Do keep loose clothing (cuffs, tie, etc.) and long hair well out of the way of moving mechanical parts. If possible wear overalls.
- Do remove rings, wristwatches etc. before working on a machine.
- Do keep your work area tidy - it is only too easy to fall over articles left lying around.
- Do ensure that any lifting tackle that has a safe working load rating adequate for the job.
- Do carry out work in a logical sequence and check that everything is correctly assembled and tightened afterwards.
- Do ensure that all guarding is fitted after servicing the machine
- Do remember that your machines safety effects that of yourself and others

If in doubt contact your local **MAJOR** dealer.

490 EAGLE WING- Overview

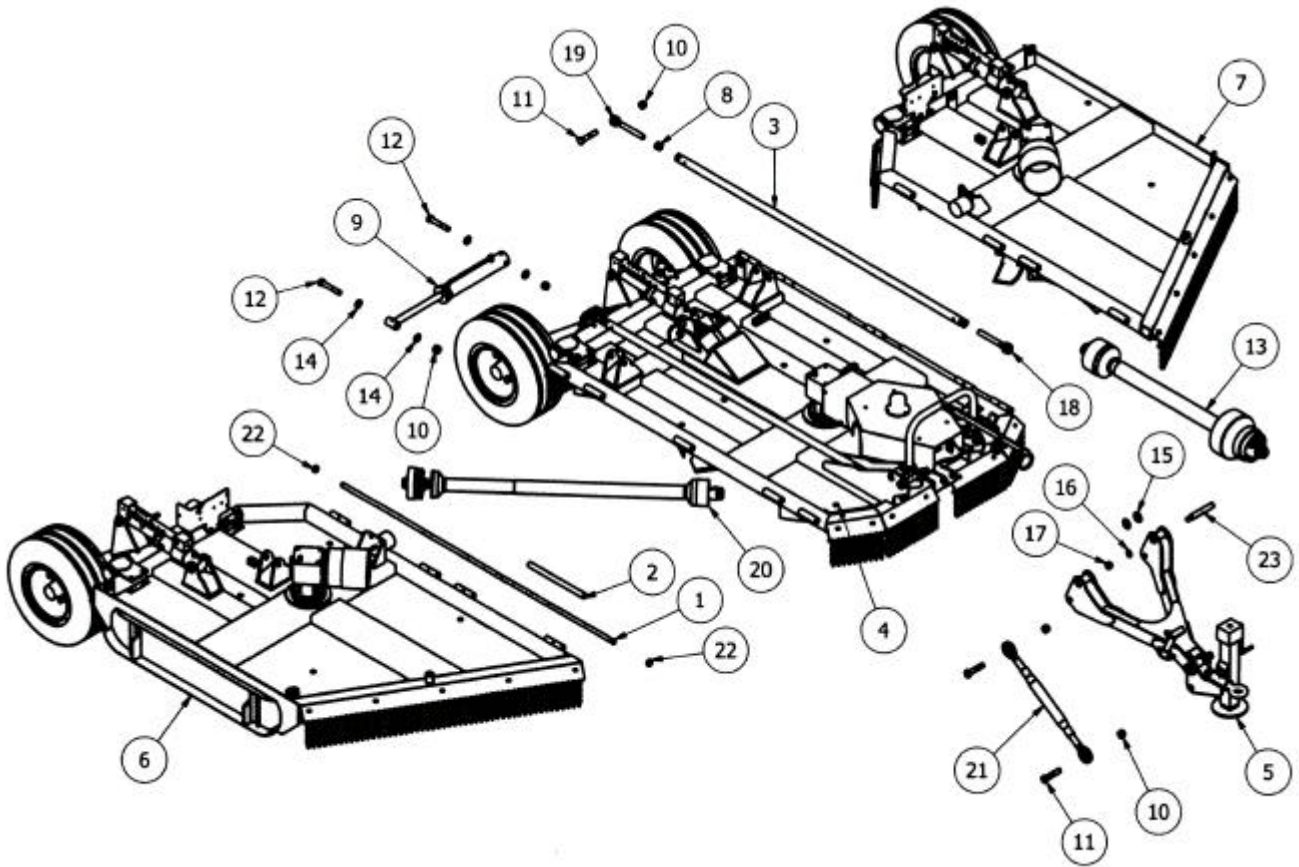

Item	Part No	Description	Qty
1	16WTHG01	WING HINGE PIN	2
2	16WTHG02	HINGE SPACER	4
3	16WTLB02	DECK LEVELING BAR	2
4	490EW-BGA	490 EW BODY ASSEMBLY	1
5	490EW-DGA	490EW DRAWBAR ASSEMBLY	1
6	490EW-WGA	490 EW WING ASSEMBLY	1
7	490EW-WGAH	490 EW WING ASSEMBLY	1
8	118CHEX	1 1/8" UNC PLAIN NUT	2
9	16WT-WRM_B	WING RAM	2
10	1F	1" FINE NYLOC NUT	8
11	1x5FBZP	Bolt	4
12	1x6FBZP	1"x6" FINE BOLT	4
13	98811210CE00203600	W/A V80 CLAMP (V80CVJ)	1
14	FW1	DIA 1" FLAT WASHER	8
15	FW114	DIA 1 1/4" FLAT WASHER	4
16	FWM24	M24 FLAT WASHER	2
17	M24	M24 NYLOC NUT	2
18	S346	TOP LINK DIA 1"x1 1/8" (LH)	2
19	S347	TOP LINK DIA 1"x1 1/8" (RH)	2
20	T601310N133F22	SLIP CLUTCH 1200 Nm	2
21	TLZ5103622-A	CAT 2-2 TOP LINK	1
22	16WTD009	SELF LEVEL BUSH	4
23	16WTD010	DRAWBAR PIVOT PIN	2

DRAWBAR

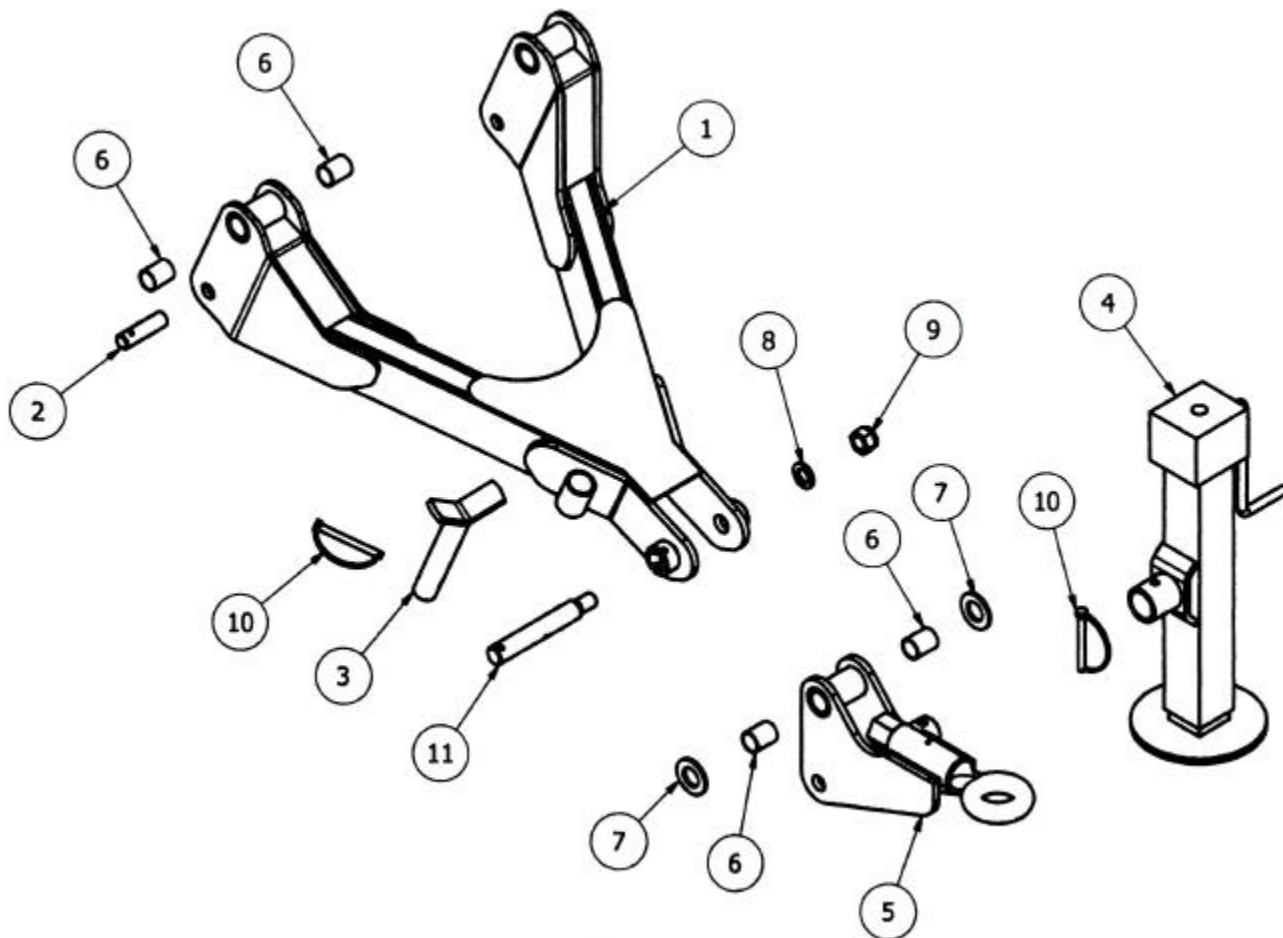

Item	Part No	Description	Qty
1	16WTD001	490EW DRAWBAR	1
2	16WTD015	SELF LEVEL PIN	2
3	16WTD020	PTO VEE STAND	1
4	16WTD025	490EW PARKING JACK	1
5	16WTH001	HITCH FAB	1
6	8SM14	DIA 1 1/4" BUSHx1 3/4"	6
7	FW114	DIA 1 1/4" FLAT WASHER	2
8	FWM24	M24 FLAT WASHER	1
9	M24	M24 NYLOC NUT	1
10	S272	SHAFT LOCK PIN DIA 11	2
11	16WTD010	DRAWBAR PIVOT PIN	1

MAIN BODY

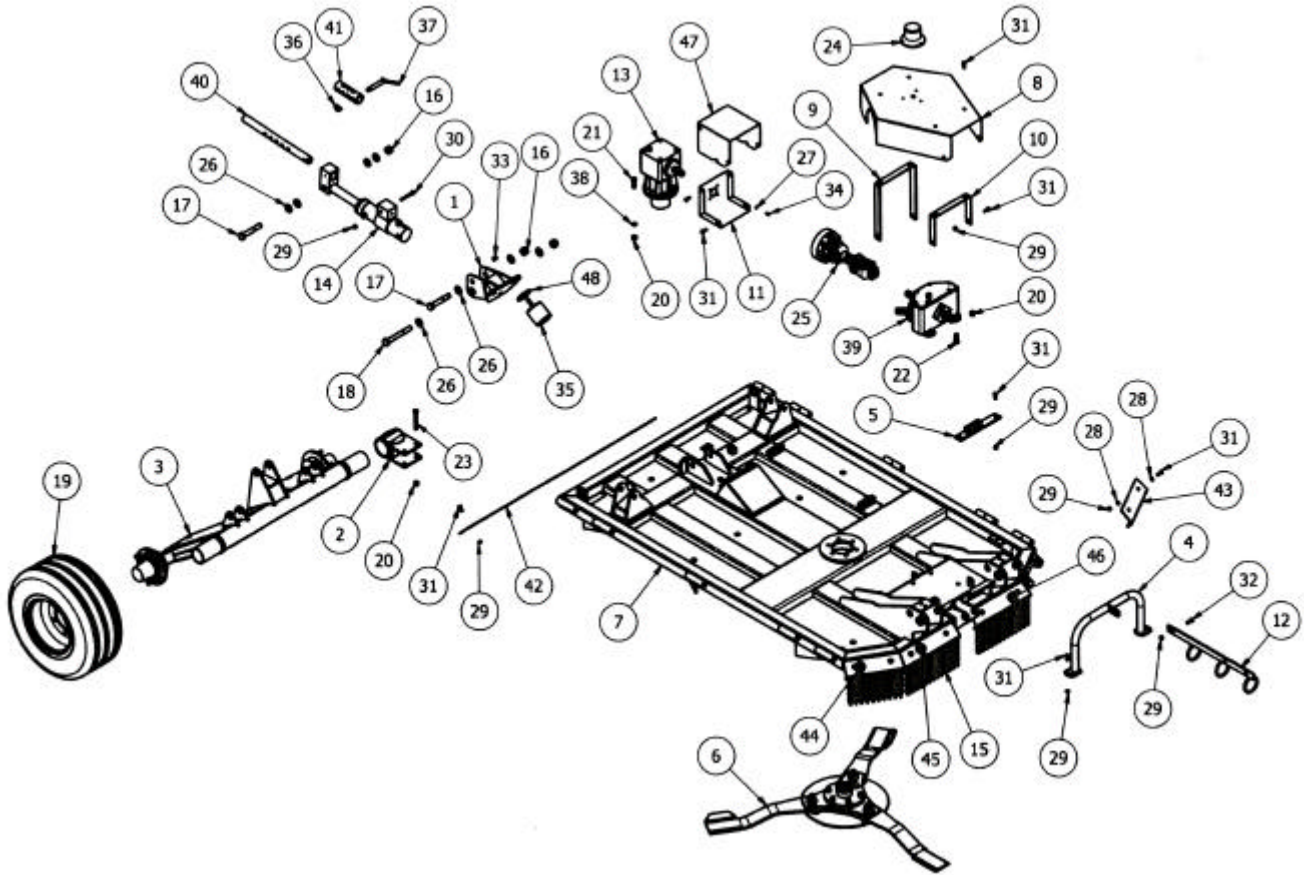

Item	Part No	Description	Qty	Item	Part No	Description	Qty
1	16TACM01	AXLE BUFFER MOUNT	1	25	E600000S133F22	SLIP CLUTCH 1200 Nm	1
2	16TAM001	AXLE MOUNT	2	26	FW1	DIA 1" FLAT WASHER	8
3	16TBA001	BODY AXLE FAB	1	27	FWM08	M8 FLAT WASHER	2
4	16THY003	CABLE GUIDE FRAME	1	28	FWM12	M12 FLAT WASHER	19
5	16THY012	HYD BLOCK MOUNT	1	29	M12	M12 NYLOC NUT	24
6	16WT-BBA	16WT BODY BLADE ASSY	1	30	M12x100BZP	M12x100 BOLT	1
7	16WTB001	490 EW BODY FAB	1	31	M12x30SZP	M12x30 SET BOLT	29
8	16WTC008	MAIN GBOX COVER	1	32	M12x35BZP	M12x35 BOLT	2
9	16WTC016	GUARD MOUNT (BACK)	1	33	M16	M16 NYLOC NUT	3
10	16WTC017	GUARD MOUNT (FRONT)	1	34	M8x16SZP	M8x16 SET BOLT	2
11	16WTC020	ROTOR COVER BASE	1	35	MOT10	DIA 105x100 BUFFER	3
12	2TKBC-2	CABLE LOCATION BAR	1	36	S3546	LINCH PIN DIA 9.5	1
13	LF149/B	LF149 GEARBOX 149.036.00	1	37	S8859	SHEAR PIN DIA 22x123mm	1
14	16WT-ARM_B	AXLE RAM	1	38	SW58	5/8" SPRING WASHER	6
15	16WTC010	5/16" CHAIN STRAP	93	39	T25A265206	20/21 SPLINE "Y" BOX RATIO 1.35:1	1
16	1F	1" FINE NYLOC NUT	3	40	16WTHS01	HEIGHT SET BAR	1
17	1x6 FBZP	1"x6" FINE BOLT	2	41	16WTHS02	HEIGHT SET TUBE	1
18	1x8FBZP	1"x8" FINE BOLT	1	42	16WTC005	CHAIN MOUNT-rear	1
19	30-11.50X14.5	DIA 720x275mm	1	43	16WTC011	CHAIN MOUNT front	1
20	58F	5/8" FINE NYLOC NUT	14	44	16WTC011H	CHAIN MOUNT front	1
21	58x214FBZP	5/8"x2 1/4" FINE BOLT	6	45	16WTC012	CHAIN MOUNT front	1
22	58x2FBZP	5/8"x2" FINE BOLT	4	46	16WTC012H	CHAIN MOUNT front	1
23	58x5FBZP	5/8"x5" FINE BOLT	4	47	16WTC023	ROTOR BOX COVER	1
24	DA49800101	LED BEACON	1	48	8T19	BUFFER SPACER	3

WING

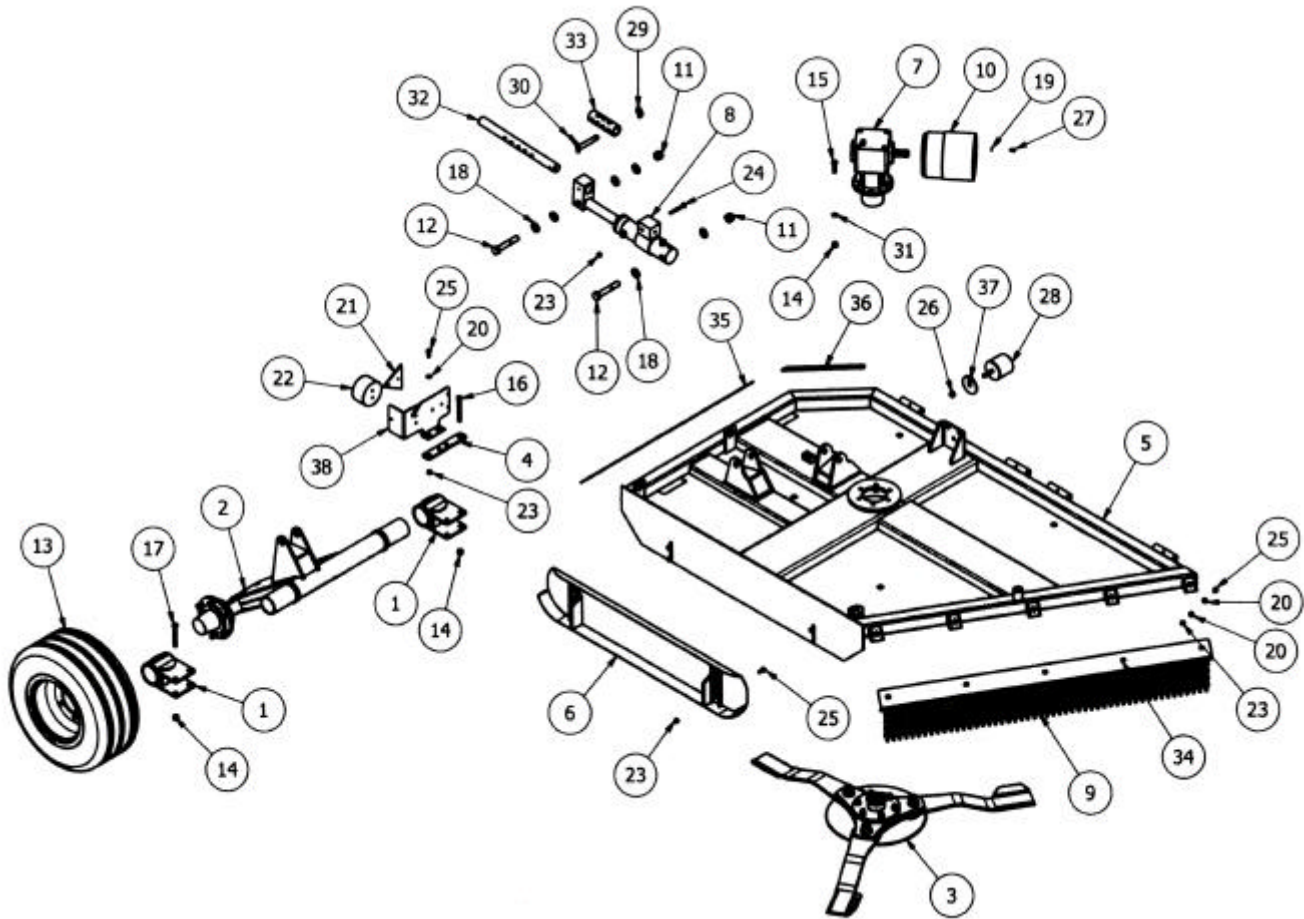

Item	Part No	Description	Qty	Item	Part No	Description	Qty
1	16TAM001	AXLE MOUNT	2	20	FWM12	M12 FLAT WASHER	17
2	16TWA001	WING AXLE FAB	1	21	LC2700	TRIANGLE REFLECTOR	1
3	16WT-WBA	16WT WING BLADE ASSY	1	22	LC360	LAMP	1
4	16WTC026	LIGHT MOUNT	1	23	M12	M12 NYLOC NUT	17
5	16WTW001	490 EW WING FAB	1	24	M12x100BZP	M12x100 BOLT	1
6	SLH16	SKID (OFFSET)	1	25	M12x30SZP	M12x30 SET BOLT	16
7	LF149BB	6 SPLINE "L" BOX RATIO 1:1.35	1	26	M16	M16 NYLOC NUT	1
8	16WT-ARM_B	AXLE RAM	1	27	M8x16SZP	M8x16 SET BOLT	2
9	16WTC010	5/16" CHAIN STRAP	99	28	MOT10	DIA 105x100 BUFFER	1
10	190000705	2 PIECE PTO GUARD	1	29	S3546	LINCH PIN DIA 9.5	1
11	1F	1" FINE NYLOC NUT	2	30	S8859	SHEAR PIN DIA 22x123mm	1
12	1x6 FBZP	1"x6" FINE BOLT	2	31	SW58	5/8" SPRING WASHER	6
13	30-11.50X14.5	DIA 720x275mm	1	32	16WTHS01	HEIGHT SET BAR	1
14	58F	5/8" FINE NYLOC NUT	10	33	16WTHS02	HEIGHT SET TUBE	1
15	58x214FBZP	5/8"x2 1/4" FINE BOLT	6	34	16WTC002	CHAIN MOUNT (WING FRONT)	1
16	58x512FBZP	5/8"x5 1/2" FINE BOLT	2	35	16WTC003	CHAIN MOUNT (WING REAR)	1
17	58x5FBZP	5/8"x5" FINE BOLT	2	36	16WTC004	CHAIN MOUNT (WING REAR)	1
18	FW1	DIA 1" FLAT WASHER	6	37	8T19	BUFFER SPACER	1
19	FWM08	M8 FLAT WASHER	2	38	TA-LGPLITL	LGP LIGHT BRACKET (LH)	1

MAIN SPLITTER GEARBOX

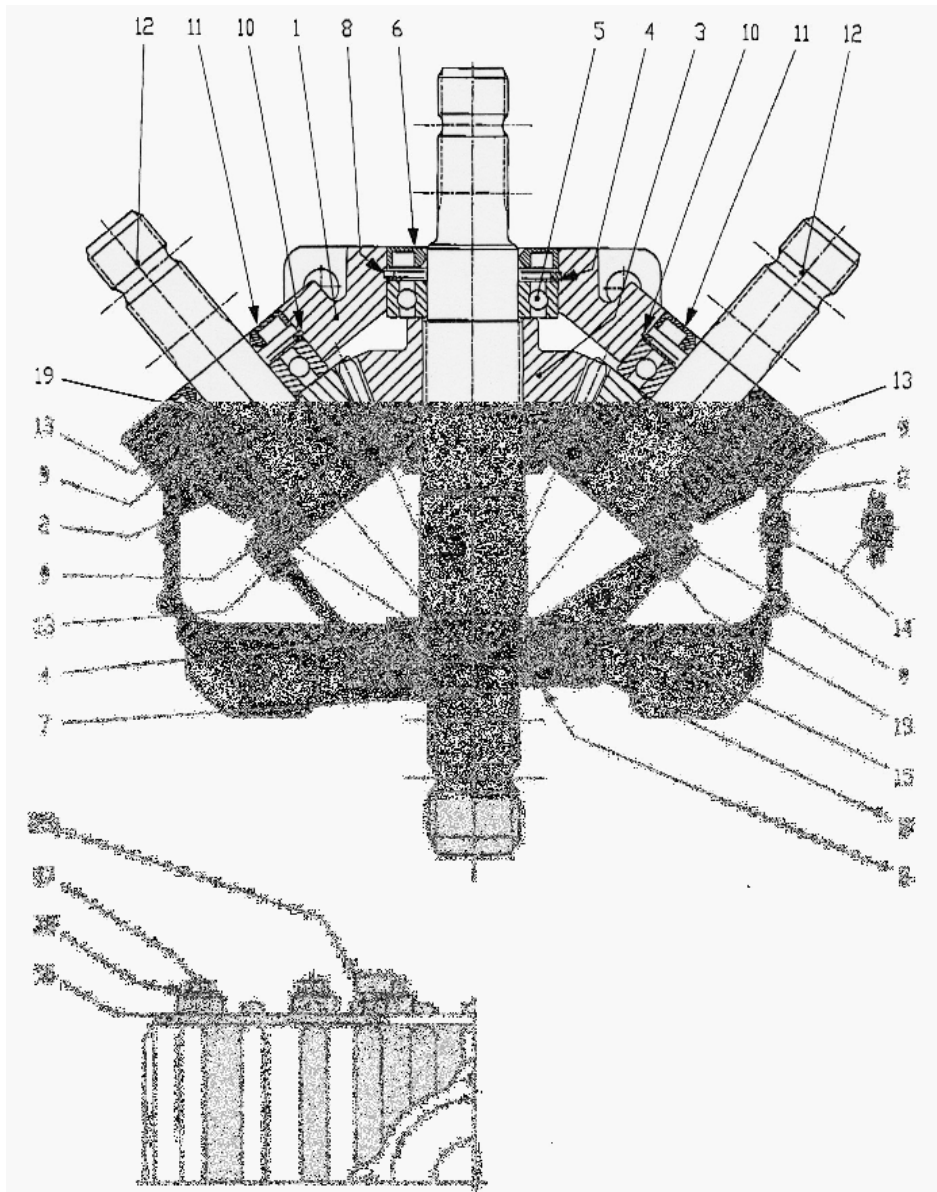

Item	Part No	Description	Qty	Item	Part No	Description	Qty
1	265030000	Gearbox Casting	1	11	87300081	Seal	2
2	265520000	Pinion	2	12	265320000	Shaft	2
3	265620100	Crown Wheel	1	13	267750000	Shim	4
4	709750000	Shim	2	14	86600201	Plug	2
5	80100761	Bearing	1	15	80100345	Bearing	1
6	87300331	Seal	2	16	254150100	Cover	1
7	265220000	Shaft	1	17	81100449	Bolt	6
8	85200332	Circlip	2	18	83700140	Washer	6
9	80100049	Bearing	4	19	85301012	Circlip	1
10	85200030	Circlip	2	251	86700269	Oil Filler Plug	1

ROTOR GEARBOX

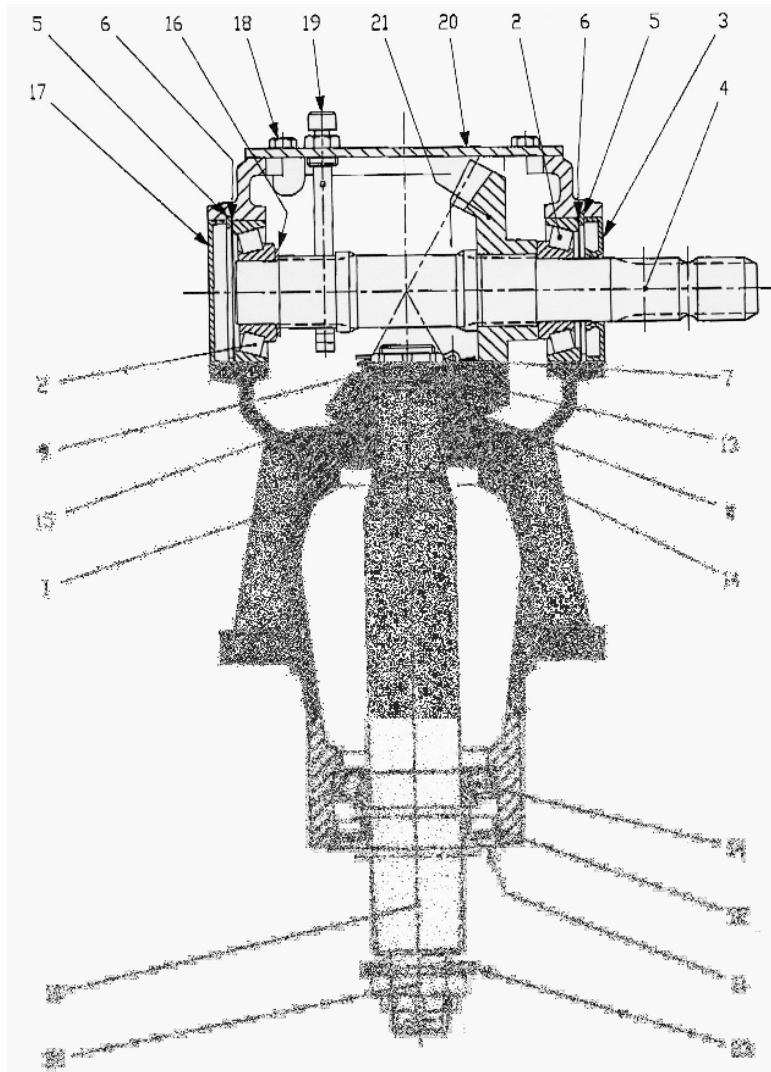

Item	Part No	Description	Qty	Item	Part No	Description	Qty
1	149030100	Gearbox Casting	1	13	102751000	Shim	1
2	80900129	Bearing	2	14	80900469	Bearing	1
3	87300081	Seal	1	15	244750000	Shim	1
4	149200100	Shaft	1	15	244750000	Shim	1
5	85200030	Circlip	2	16	259752500	Shim	1
6	267750000	Shim	2	17	87000790	Cap	1
7	84701111	Cotter Pin	1	18	81100326	Bolt	4
8	149500000	Pinion	1	19	149710000	Plug	1
8	149500200			20	149130000	Cover	1
9	132710600	Nut	1	21	149500000	Crown Wheel	1
10	149300000	Shaft	1	21	149600100		
10	149300000	Shaft	1	22	LF135-1	Nut	1
11	139710000	Dust Seal	1	23	LF135-2	Washer	1
12	87101107	Seal	1		80900128		1

SLIP CLUTCH SET-UP DIMENSIONS

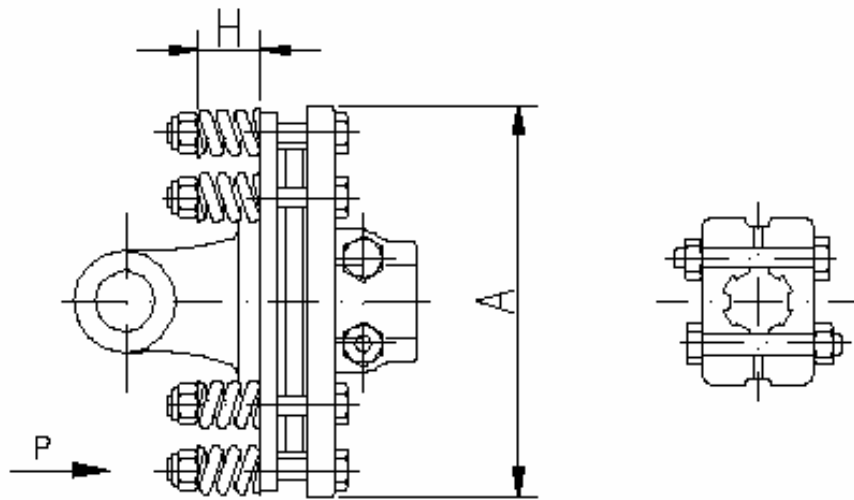

<i>P. daN</i>	<i>H. mm</i>	<i>daNm.</i>	<i>A. mm</i>
320	33.4	90	195
356	33.2	100	
425	32.9	120	
448	32.7	125	
509	32.2	140	
545	31.7	150	
—	—	—	

Recommended torque setting is between 100 –120 daNm to protect the PTO shaft.
Dimension H should be between 33.2 and 32.9mm.

BLADE ASSEMBLY

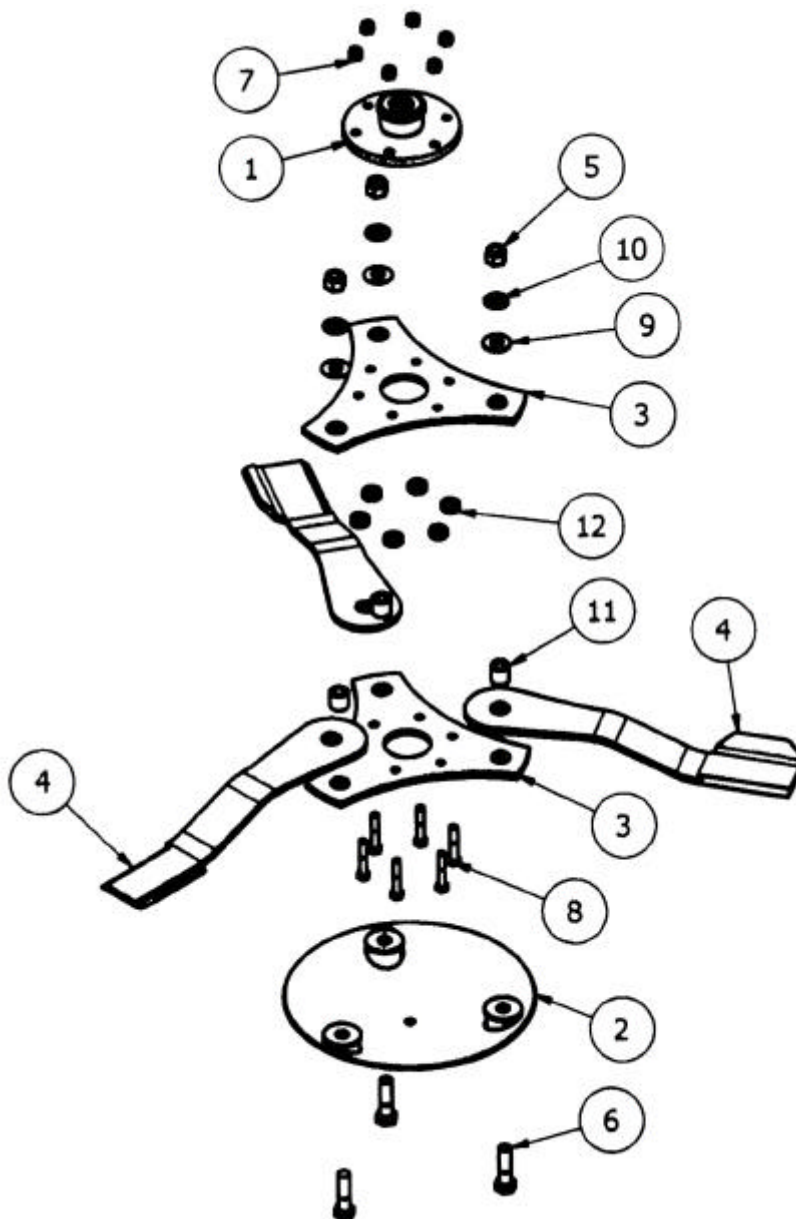

Item	Part No	Description	Qty
1	16WT-BM1	Blade Mount	1
2	16WT-USS	Undersole Skid	1
3	16WT-BBK	Blade Back	2
4	16WT-BB	Body Blade	3
4	16WT-WB	Wing Blade	3
5	1F	Nut	3
6	1x312FBZP	Bolt	3
7	58F	5/8" Nut	6
8	58x314FBZP	Bolt	6
9	D60253	Disc Spring Washer	3
10	FW1	Flat Washer	3
11	16WT-BBB	Blade Back Bush	3
12	16WT-BBS	Blade Back Spacer	6

WIRING DIAGRAMS

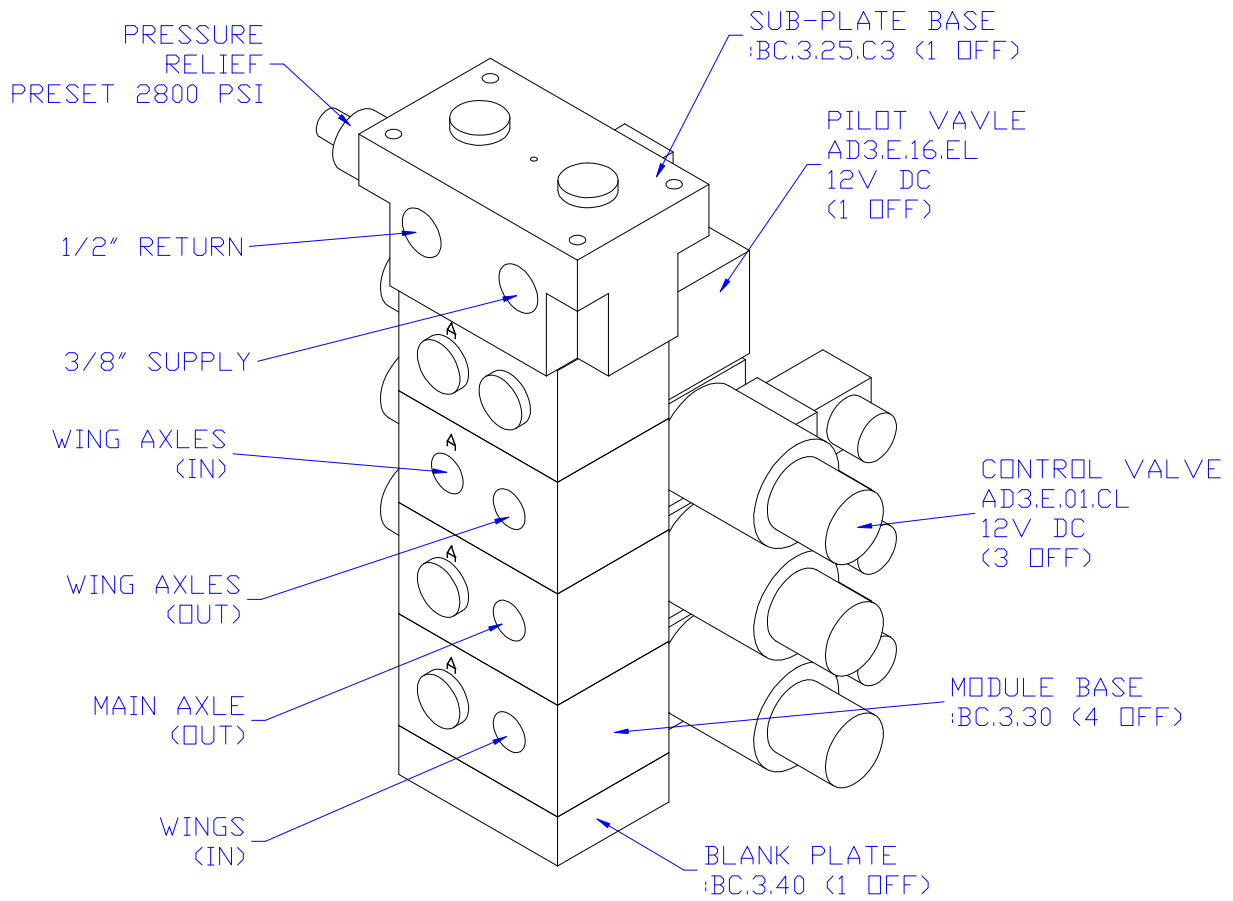

SOLENOID VALVE

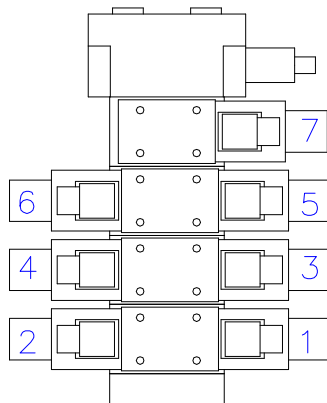

SOLENOID IDENTIFICATION

HYDRAULIC MANUAL CONTROL

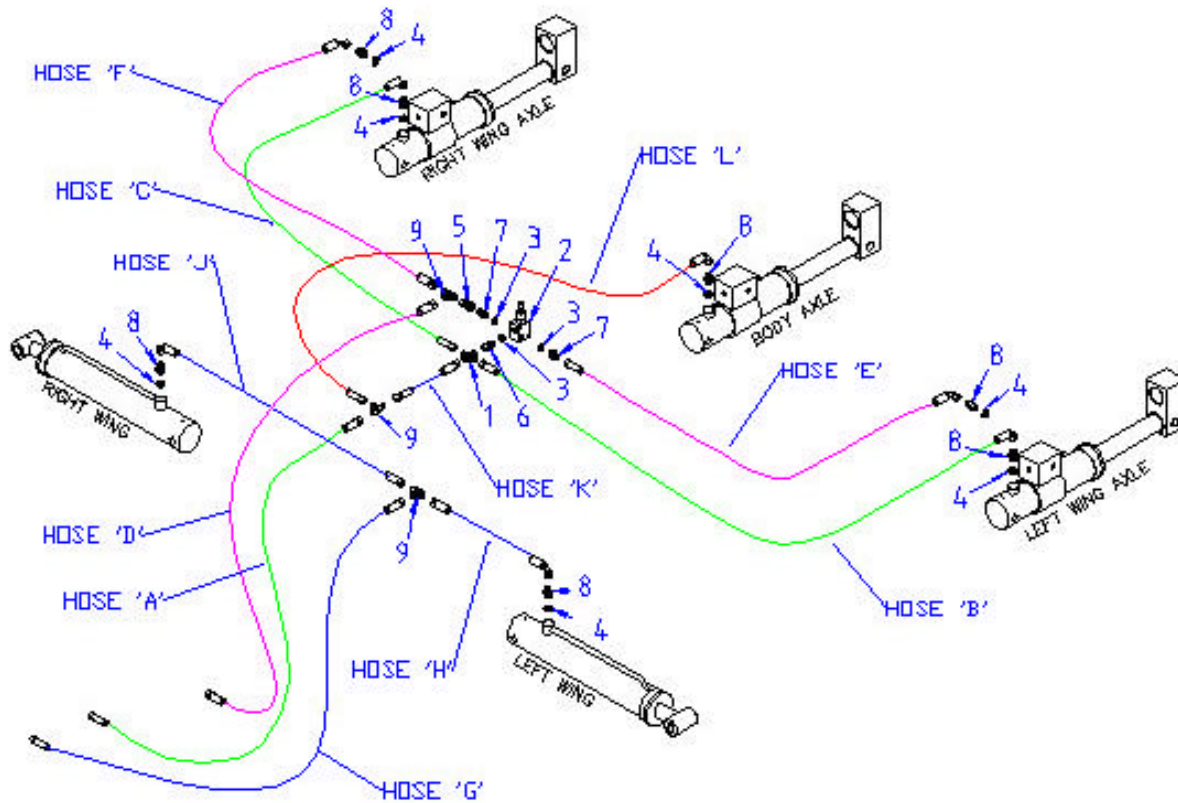

HOSE (∅)	LENGTH	FITTING	FITTING	QTY
A-1/4"	4880mm	1/4" STRAIGHT	1/2" MALE QUICK FIT.	1
B-1/4"	1740mm	1/4" BLOCK 90	1/4" STRAIGHT	1
C-1/4"	2540mm	1/4" BLOCK 90	1/4" STRAIGHT	1
D-1/4"	5000mm	1/4" STRAIGHT	1/2" MALE QUICK FIT	1
E-1/4"	1890mm	1/4" BLOCK 90	1/4" STRAIGHT.	1
F-1/4"	2870mm	1/4" BLOCK 90	1/4" STRAIGHT.	1
G-1/4"	5000mm	1/4" STRAIGHT	1/2" MALE QUICK FIT	1
H-1/4"	610mm	1/4" BLOCK 90	1/4" STRAIGHT.	1
J-1/4"	1420mm	1/4" BLOCK 90	1/4" STRAIGHT.	1
K-1/4"	100mm	1/4" STRAIGHT	1/4" STRAIGHT.	1
L-1/4"	550mm	1/4" BLOCK 90	1/4" STRAIGHT.	1

ITEM.	PART NO.	DESCRIPTION	QTY
1	14CROSS	1/4" M/M/M/M Connector	1
2	8SM-RRV	Pressure Relief Valve	1
3	EDOW14	1/4" Dowty Washer	3
4	EDOW38	3/8" Dowty Washer	7
5	EFF14	1/4" F/F Connector	1
6	EMF14	1/4" M/F Connector	1
7	EMM14	1/4" M/M Connector	2
8	EMM1438	1/4-3/8" M/M Connector	7
9	EMMMT14	1/4" M/M/M Connector	3

HYDRAULIC SOLENOID CONTROL (OPTION)

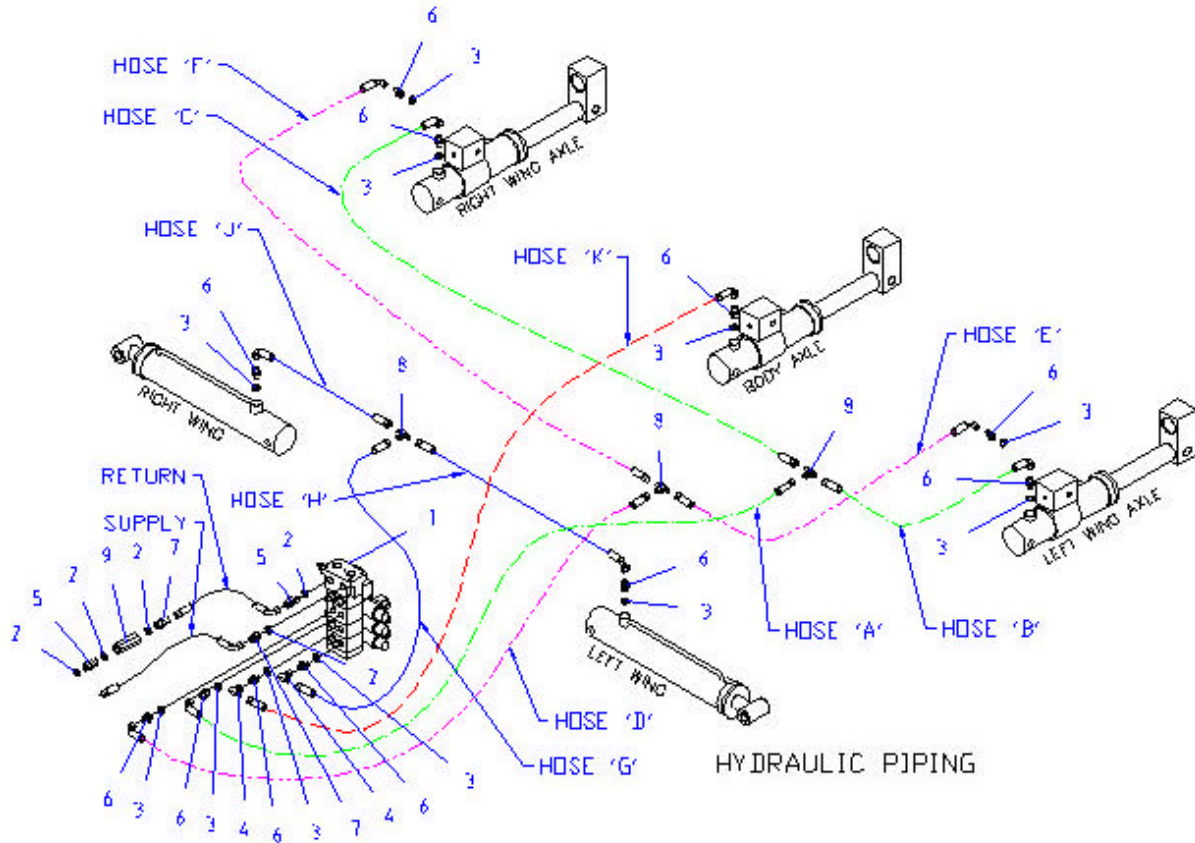

HOSE (∅)	LENGTH	FITTING	FITTING	QTY
A-1/4"	2000mm	1/4" BLOCK 90	1/4" STRAIGHT	1
B-1/4"	1740mm	1/4" BLOCK 90	1/4" STRAIGHT	1
C-1/4"	2540mm	1/4" BLOCK 90	1/4" STRAIGHT	1
D-1/4"	2000mm	1/4" BLOCK 90	1/4" STRAIGHT	1
E-1/4"	1890mm	1/4" BLOCK 90	1/4" STRAIGHT	1
F-1/4"	2870mm	1/4" BLOCK 90	1/4" STRAIGHT	1
G-1/4"	1880mm	1/4" STRAIGHT	1/4" STRAIGHT	1
H-1/4"	610mm	1/4" BLOCK 90	1/4" STRAIGHT	1
J-1/4"	1260mm	1/4" BLOCK 90	1/4" STRAIGHT	1
K-1/4"	2440mm	1/4" BLOCK 90	1/4" STRAIGHT	1
SUPPLY-3/8"	3000mm	3/8" BLOCK 90	1/2" MALE QUICK FIT	1
RETURN-1/2"	3000mm	1/2" BLOCK 90	1/2" MALE QUICK FIT	1

ITEM.	PART NO.	DESCRIPTION	QTY
1	16WT-4C3	Valve Bank	1
2	EDOW12	1/2" Dowty Washer	5
3	EDOW38	3/8" Dowty Washer	11
4	EFM9014	1/4" M/F Elbow	2
5	EMM12	1/2" M/M Connector	3
6	EMM1438	1/4-3/8" M/M Connector	11
7	EMM3812	3/8-1/2" M/M Connector	1
8	EMMMT14	1/4" M/M/M Connector	3
9	VR13	1/2" Check Valve	1

490 EAGLE WING SOLENOID CONTROL WIRING DIAGRAM

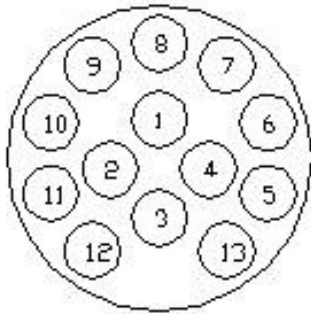

Plug & Socket Layout

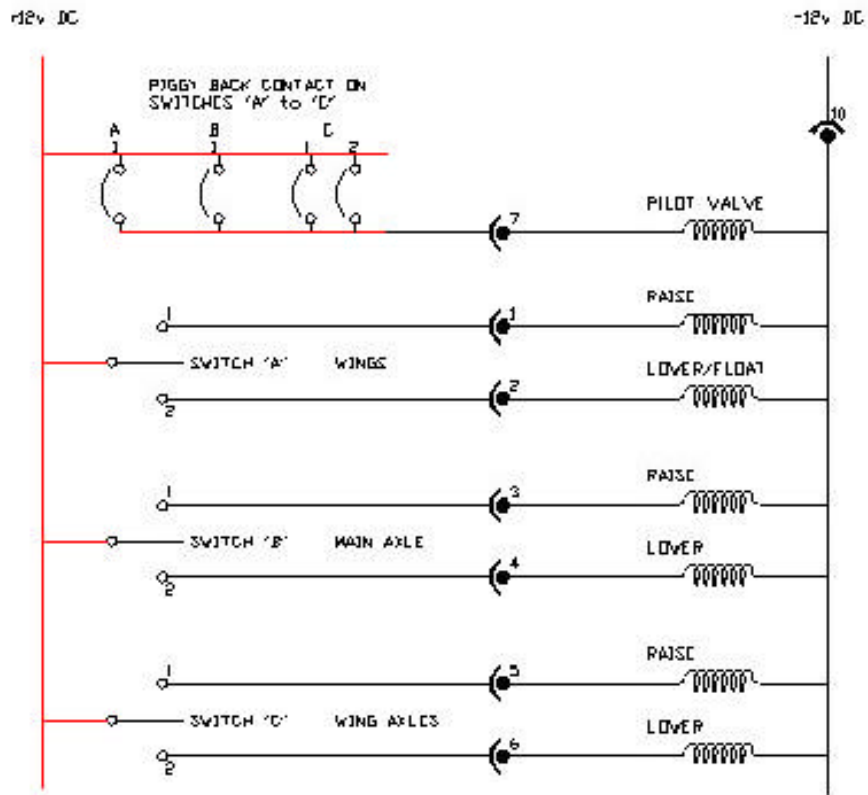
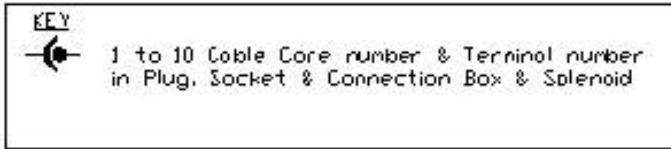

PART NO.	DESCRIPTION	QTY
GW44207	Control Box	1
GW44205	Terminal Box	1
ZB4-BD5	Switch 3 Position	2
ZB4-BD7	Switch 3 Position	1
BE-101	Contact Block	7
LD2-272	Switch Grid	3
TDD-CC20	Control Box Mount	1
S7103-1	Suction Mount	1

NOTES