



CYCLONE

Operator Manual & Parts List

MAJOR
CYCLONE
MOWER

MJ35-150

MJ35-170



Head Office

Major Equipment Intl. Ltd.
Ballyhaunis,
Co. Mayo,
Ireland.

Tel.: +353 (0) 9496 30572
Fax: +353 (0) 9496 30788
Email: info@major-equipment.com

UK Office

Major Equipment Ltd.
Major Industrial Estate,
Middleton Rd.,
Heysham,
Lancs.
LA3 3JJ

Tel.: +44 (0) 1524 850 501
Fax: +44 (0) 1524 850 502
Email: ukinfo@major-equipment.com

NETHERLANDS & GERMANY OFFICE

Major Equipment Intl. Ltd.
Postbus 29,
NL-7700 AA ,
Dedemsvaart,
Nederland.

Tel: +31 (0) 6389 19585
Email: euinfo@major-equipment.com

Web: www.major-equipment.com



Find us on FACEBOOK
MAJOR MACHINERY



View our channel
MAJOREQUIPMENT

Disclaimer

While every effort has been made in the production of this manual to ensure that the information contained herein is full and correct, Major assumes no responsibility for errors or omissions.

Major reserves the right to modify the machinery and the technical data contained within the manual without prior notice.

Further to this, Major assumes no liability for any damages which may result from the use of the information contained within this manual.

Contents

Introduction

Thank you	1
Safety Aspects	1
Intended use	1

Product Identification

Machine Serial Numbers	1
Register Your Product and Warranty Online	1
Product Specifications	2
Tractor Requirements	2

Safety

Machine Safety Labels	3
Hazards associated with operating Grass Cutting Machinery	4
Operating Safely	5
Workstation	5
Regulations for use of the transmission	5
PTO Shaft Safety	6
Driving Safely on Public Roads	6

Operating the Machine

Key to Main Parts	7
Inspections before Use	8
Starting Regulations	8
Attaching the machine to the tractor	9
Operating the Machine/Mowing	10
Castor wheels and roller adjustment	10
AVANT hydraulic attachment	11

Maintenance

Machine storage	12
PTO Shaft Maintenance	12
Replacement of wear parts	13
Blade Rotation	13
Lubrication schedule	14
Clearing out a blockage	14
Troubleshooting	14

Spare Parts - MJ35

MJ35-150 Cyclone Mower	16
MJ35-150 Parts List	16
MJ35-150	17
MJ35-150 Parts List (Continued)	17
MJ35-170 Cyclone Mower	18
MJ35-170	19
MJ35-170 Parts List	19
Wheel assembly (RM2-CW-GA01) (MJ35 and MJ61 models)	20
PTO shafts (MJ35)	20
Tractor Linkage arms (MJ35 and MJ61 models)	20
MJ35 Blades	21
775-DCBLDTX-L TYPE 1 (MJ35-150)	21
775-DCBLDTX-R TYPE 1 (MJ35-150)	22
775-DCBLDTX-L TYPE 2 (MJ35-150)	23
775-DCBLDTX-R TYPE 2 (MJ35-150)	24
640-DCBLDTXS-L (MJ35-170)	25
640-DCBLDTXS-R (MJ35-170)	26
MJ40T4-347.803-1.47-1	27

EEC certificate of conformity for machines

(conforming to Directive 2006/42/EC)

Name of Manufacturer: Major Equipment Ltd
Address: Coolnaha, Ballyhaunis, Co. Mayo, Rep of Ireland

Tel. +353949630572
Fax +353949630788

declares in sole responsibility that the product:

Machine description and function: Rotary mower with vertical axes cutting heads which cuts grass so it can be subsequently picked up.

Model: Cyclone (MJ35)

Type: _____

Serial number: _____

Technical file compiled by: Alex Kolchanov (c/o Major Equipment Ltd)

- **THE SUPPLY OF MACHINERY (SAFETY) REGULATIONS 2008.**
- **S.I. No. 299 of 2007**, Safety, Health and Welfare at Work (General Application) Regulations 2007 (Ireland).
- **Health & Safety at Work, etc. Act 1974 (c.37) (UK).**
- **EN ISO 14121-1: 2007** 'Safety of machinery. Principles for risk assessment'.
- **EN 745** - Agricultural Machinery - Rotary Mowers and Flail Mowers - Safety.
- **EN ISO 13857** - Safety of machinery: Safety distances to prevent hazard zones being reached by upper and lower limbs.

I hereby certify on behalf of Major Equipment Int. Ltd., that this machine when properly installed and operated correctly, complies with all the essential Health & Safety requirements of all legislation referred to above.

Signed:  _____

Date: 14/11/2018

Name: John Murphy

Position: Managing Director

Place: Coolnaha, Ballyhaunis, Co. Mayo, Rep of Ireland

Introduction

Thank you

We appreciate having you as a customer and wish you many years of safe and satisfied use of your machine.

Safety Aspects

This manual is an important part of your machine and should remain with the machine when you buy it. Reading your operator's manual will help you and others avoid personal injury or damage to the machine. Information given in this manual will provide the operator with the safest and most effective use of the machine. Only competent and skilled persons who have fully read and understood this operator's manual are allowed to operate this machine.

Sections in your operator's manual are placed in a specific order to help you understand all the safety messages so you can operate this machine safely. You can also use this manual to answer any specific operating or servicing questions.

Your manual contains special messages to bring attention to potential safety concerns, machine damage as well as helpful operating and servicing information. Please read all the information carefully to avoid injury and machine damage. Should any questions arise regarding the information given in this booklet, please contact your local MAJOR dealer or MAJOR.

The operator is solely responsible for the safe use and maintenance of the machine. The machine must only be operated by a competent and skilled person. Setting up and adjustment must only be carried by the operator. Do not let a third party person to adjust or modify the machine in any way.

Intended use

This machine is a grass cutting machine and designed for cutting grass. Moreover, it must only be used with a suitable tractor (see "Product Specifications" section of this booklet) and driven by an adequate drive-line of the tractor PTO. All other use is strictly prohibited. Major will not be held responsible for any loss or damage caused due to a misuse of the machine.

Product Identification

Machine Serial Numbers

If you need to contact MAJOR or your MAJOR dealer for information on servicing or spare parts, always provide the product model and serial numbers. Model and Serial number can be found on the Serial Plate located on the machine.

We suggest that you record your machine details below:

Model No: _____

Serial No: _____

Date of Purchase: _____

Dealer Name: _____

Dealer Telephone: _____

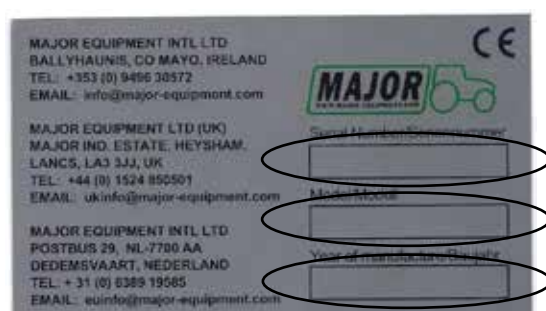

Register Your Product and Warranty Online

To register your product through the Internet, simply go to the Support section on www.major-equipment.com. Completing the information, either online or with the product warranty card, will ensure the customer that their product receives all post sales service and important product information.

This machine is warranted for 12 months with. No warranty is given where the machine is being used as a hire machine. Warranty is against faulty workmanship or parts.

Warranty covers parts only. All parts must be returned to the manufacturer. No warranty can be considered unless parts are returned. All replacement parts will be supplied on a chargeable basis until warranty has been accepted.

Product Specifications

Model	MJ35-150	MJ35-170
Overall Width	1.6m	1.8m
Height	0.5m	0.5m
Depth	1.4m	1.4m
Working Width	1.49m	1.7m
No. of Blades	8	12
No. of Rotors	2	3
Power/Oil Flow	20HP	25HP
PTO (RPM)	2000	2000
Blade tip speed	85m/s	85m/s
Cutting Height	0-118mm	0-118mm
Weight (kg)	300	

Tractor Requirements



Attaching the machine to the tractor will influence the stability and manoeuvrability of the tractor. Please consult your tractor manual for limitations on weight and towing ability of the tractor.

It is the operator's responsibility to ensure that the tractor is suitable for the machine. Always consult your tractor's manual for any further information required.

Recommended Horse Power requirements for the particular models are provided in the "Product Specification" section of this booklet. Using excessive power can affect the quality of cut and/or may damage the machine.

Tractors which are not suitable for the operation can sustain damage due to the weight and power requirements of the machine. Always observe the weight of machine provided in the "Product Specification" section of this booklet, compare this with the guidelines from the tractor manual and ensure that the tractor can lift the machine safely.

The machine is designed to be attached by means of a 3 point linkage connection. The position of the machine can be adjusted by manual or hydraulic top link.

Winged models require one hydraulic spool with 1/2" female quick release connection for a single acting ram/rams.

Road light kit requires a 12V 7 pin socket.

The machine is propelled by using a standard 6 spline 1-3/8" PTO shaft (provided with the machine). This machine can be driven by a hydraulic motor (optional)

Safety

Machine Safety Labels

The machine safety labels shown in this section are placed in important areas on your machine to draw attention to potential safety hazards.

On your machine safety labels, the words DANGER, WARNING, and CAUTION are used with this safety alert symbol. DANGER identifies the most serious hazards.

The operator's manual also explains any potential safety hazards whenever necessary in special safety messages that are identified with the word, CAUTION, and the safety-alert symbol



To avoid injury, read the manual

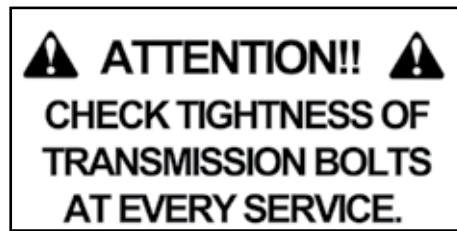

Check the tightness of the transmission



PTO entanglement hazard - keep clear of PTO drives.

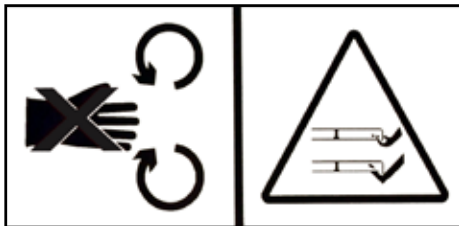

Rotating blade hazard



MAX PTO input 2000 RPM



Grease points



High oil pressure hazard

Hazards associated with operating Grass Cutting Machinery

Shear Hazard

Shear hazards are created when the edges of two objects move toward or next to each other closely enough to cut relatively soft material. This can include the parts of the machine under hydraulic control when operating from transport to mowing position. Note, the wing units are designed to float independently of the centre deck & are free to move within operating limits.

Crush Hazard

Bystanders can be injured when machine is lowered into mowing position. Winged machines have crush points around the hinge areas & between the wing & main body. Always use transport locking bars when not in use (winged models only).

Rotating Blade Hazard

All persons are at risk if they place their hands or feet under the machine when it is raised from the ground when the blades are in motion.

Pinch Hazard

Pinch points are created when two objects move together, with at least one of them moving in a circle. This hazard is common in power transmission devices such as Belt Drives, Gear Drives & Rollers. Ensure all guarding is present.

Wrap Hazard

Any exposed, rotating machine component is a potential wrap point. Injuries usually occur when loose clothing or long hair catch on and wrap around rotating parts such as PTO shafts or Drive shafts on the machine. Ensure all guarding is present.

Free-wheeling parts Hazard

The heavier a revolving part is, the longer it will continue to rotate after power is shut off. This characteristic is called 'free-wheeling.' Blades, and various other components, drive shafts etc., will continue to move after power is shut off - often for several minutes. Injuries occur when:

- Operators shut off equipment, and attempt to clean or adjust a machine before components have completely stopped moving.
- Shear bolt protection device in PTO shaft shears & the mowing parts are still spinning but the primary PTO shaft is stationary. Operator awareness is the key to safety around freewheeling parts. Never raise the machine while the blades are still rotating.

Thrown objects Hazard

Machines throw material as a natural part of doing their job. Foreign objects, such as stones, sticks and other debris, may be taken into this equipment and expelled at tremendous speed. These objects are contained by the sides of the machine and by the rear/front rollers / guards / chain guards / rubber skirts depending on model of your machine.

Ensure bystanders are clear from the machine & cannot be hit with debris expelled from the machine. Bystanders or animals in the path of thrown objects could be seriously injured. Never operate machine with decks raised from the ground as this makes the front/rear protection redundant.

Hydraulic Hazard (if applicable)

Hydraulic systems store considerable energy. Careless servicing, adjustment, or replacement of parts can result in serious injury. High pressure blasts of hydraulic oil can injure eyes or other body parts. The following precautions are crucial:

- Make certain the hydraulic pump is turned off.
- Lower attached equipment to the ground.
- Confirm that load pressure is off the system.

A pinhole leak in an hydraulic hose is a serious hazard. A leak may not be visible, and the only sign may be a few drops of fluid. Never inspect hydraulic hoses with your hands, because a fine jet of hydraulic fluid can pierce the skin.

Slips, Trips and Falls Hazard

Slips and falls often result from:

1. Slippery footing on the ground
2. Cluttered steps and work platforms.

The potential for slips and falls can be greatly reduced by using good judgement and practicing good housekeeping on and around equipment.

Noise Hazard

Please note that the machine is normally used outdoors and that the position of the operator is seated in the driving seat of the tractor. It is advisable to consult the prescriptions listed in tractor operator and maintenance manuals.

The acoustic pressure at a distance of 2.6m from the centre of the machine and at a height of 2.0m, with the implement operating in a no load condition can reach 90 dBA. In a loaded condition & a PTO rate of 540 rpm the value can reach 97dBA. Higher rate of PTO input will result in in higher noise levels. Always wear hearing protection.

Operating Safely

This MAJOR machine is designed to operate at a PTO rate which is stated in the Product Specifications part of this booklet. Ensure tractor PTO output is set at a correct RPM rate. This MAJOR machine must only be used for purposes outlined in the Intended Use section of this booklet. All other use is strictly prohibited.



Users should become thoroughly familiar with the contents of this manual before using, servicing and mounting the implement to the tractor and all other pertinent operations. Never wear jewellery, loose clothing such as ties, scarves, belts, unbuttoned jackets or dungarees with open zips which could become caught up in moving parts.



Always wear approved garments complying with accident prevention provisions such as non-slip shoes, ear muffs, goggles and gauntlets. Wear a jacket with reflecting stickers if the implement is used near public highways.



Consult your retailer, the Labour Health Service or your nearest equivalent authority for the information about the current safety provisions and specific regulations with in order to ensure personal safety.



ALWAYS DISENGAGE PTO, SWITCH OFF THE TRACTOR ENGINE AND ENGAGE THE PARKING BRAKE BEFORE MAKING ADJUSTMENT TO THE MACHINE.



NEVER PLACE LIMBS UNDER THE MACHINE WHILE ROTOR(S) ARE TURNING. ROTOR(S) CAN REMAIN TURNING FOR UP TO 1 MINUTE AFTER DISENGAGING PTO.

Workstation

The operator must remain seated while working the machine. If the machine is a winged unit and the wings need to be raised/lowered the operator must not leave the tractor. Always ensure the PTO has been turned off and the parking brake applied before leaving the tractor cab or carrying out maintenance.



NEVER OPERATE THE HYDRAULICS WITH THE TRACTOR SWITCHED OFF

Regulations for use of the transmission

The transmission to the gearboxes is protected throughout the machine by both PTO shafts and bolt down covers. All guarding should be kept efficient and in good condition. If the condition is poor, the guarding should be renewed before the implement is used.



UNLESS IT IS CORRECTLY PROTECTED THE TRANSMISSION COULD CAUSE DEATH SINCE IT CAN CATCH ON PARTS OF THE BODY OR CLOTHING

Ensure retaining chains are correctly anchored on all PTO shafts, preventing them from turning. Ensure drive line can turn easily within the shield. Keep spline grooves clean and greased so that PTO shaft can connect easily. Besides being described in this booklet, the method by which the PTO shaft is connected to the tractor must be checked out with the instructions in the tractor manufacturer's manual.

PTO Shaft Safety

Maximum PTO input is specified in the Product Specifications section of this booklet. Contact your nearest dealer or a specialised retail outlet if the PTO must be replaced with a longer one, since this must belong to the same power category and possess the same characteristics. An unsuitable PTO could easily break.

The tractor PTO shaft length may be altered to suit the individual tractor model. When the machine is in operation, the PTO shaft should have a minimum 1/3 engagement as shown in the diagrams. After the machine has been hitched to the tractor, it should be checked in various positions that the drive line is the correct length. If the PTO is too short and tends to slip out of place, it must be replaced with a longer one.

If the PTO shaft is too long, it should be shortened in the following way:

- Set the machine at a minimum distance from the tractor, then brake the tractor and switch off the engine.
- Separate the two halves of the PTO. Insert the female part into the tractor PTO and the male part into the machine PTO, checking that the position is correct by means of the fixing pins.
- Line up the two halves of the PTO together, keeping them parallel.
- Using a felt tip pen, match mark the place where the two halves must be shortened as shown.
- First cut shield "1" and use part "2" as a reference to cut the splined shaft.
- Proceed in the same way for the second half.
- Trim and chamfer the two cut ends of the PTO and clean off all swarf and shavings.
- Grease the two profiles and join the two halves of the PTO together.
- Mount the PTO shaft and check that its length is correct as before.



Do not use the shaft cone as a step

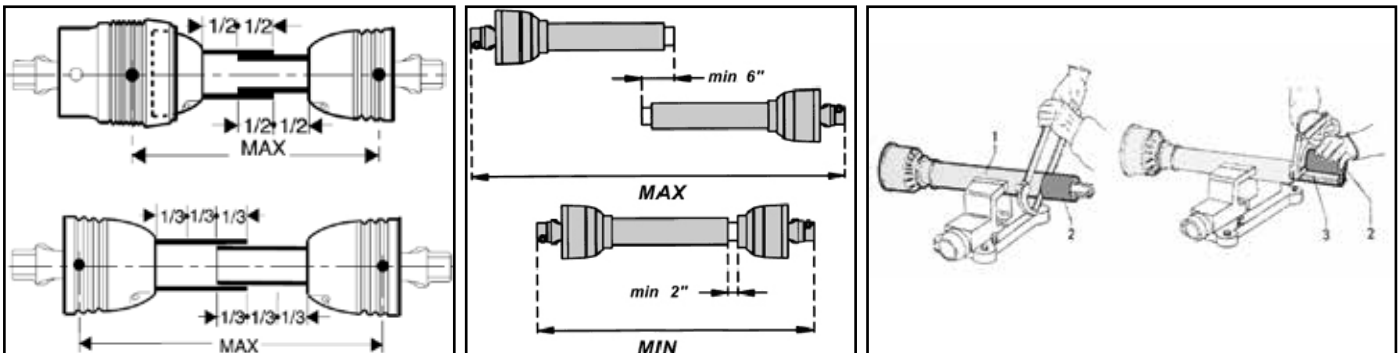

Driving Safely on Public Roads

Check the local Highway Code regulations before driving the tractor on public highways with an implement attached. Check the reflectors, hazard flashers and/or projecting load indicators are installed when required and efficient. These indicators must be installed correctly and easily seen by the drivers of other vehicles.

Bystanders must not be allowed to lean against or climb onto the machine during transport or while working. Do not allow bystanders to ride on the machine.



MAXIMUM TRANSPORT SPEED MUST NOT EXCEED 30 km/hr (18 MPH)

General safety instructions

Precautions to be taken while working with the machine:

1. Do not operate the machine when you are tired or under the influence of alcohol or any other intoxicant;
2. Before starting mowing, make sure that the area is clear of people or animals.
3. Before starting adjusting the machine, it is mandatory to disconnect the PTO, to turn off the engine of the tractor, apply handbrake and wait for the turning parts to become still and placed on the ground.
4. It is mandatory to read all the safety requirements and the operator's manual of the machine.
5. If you are not sure how to use the machine, please contact the manufacturer or the dealer.

Operating the Machine

The machine is designed to be installed on the front part of the tractor. The machine must be connected to the tractor by using a special linkage connection.

Key to Main Parts

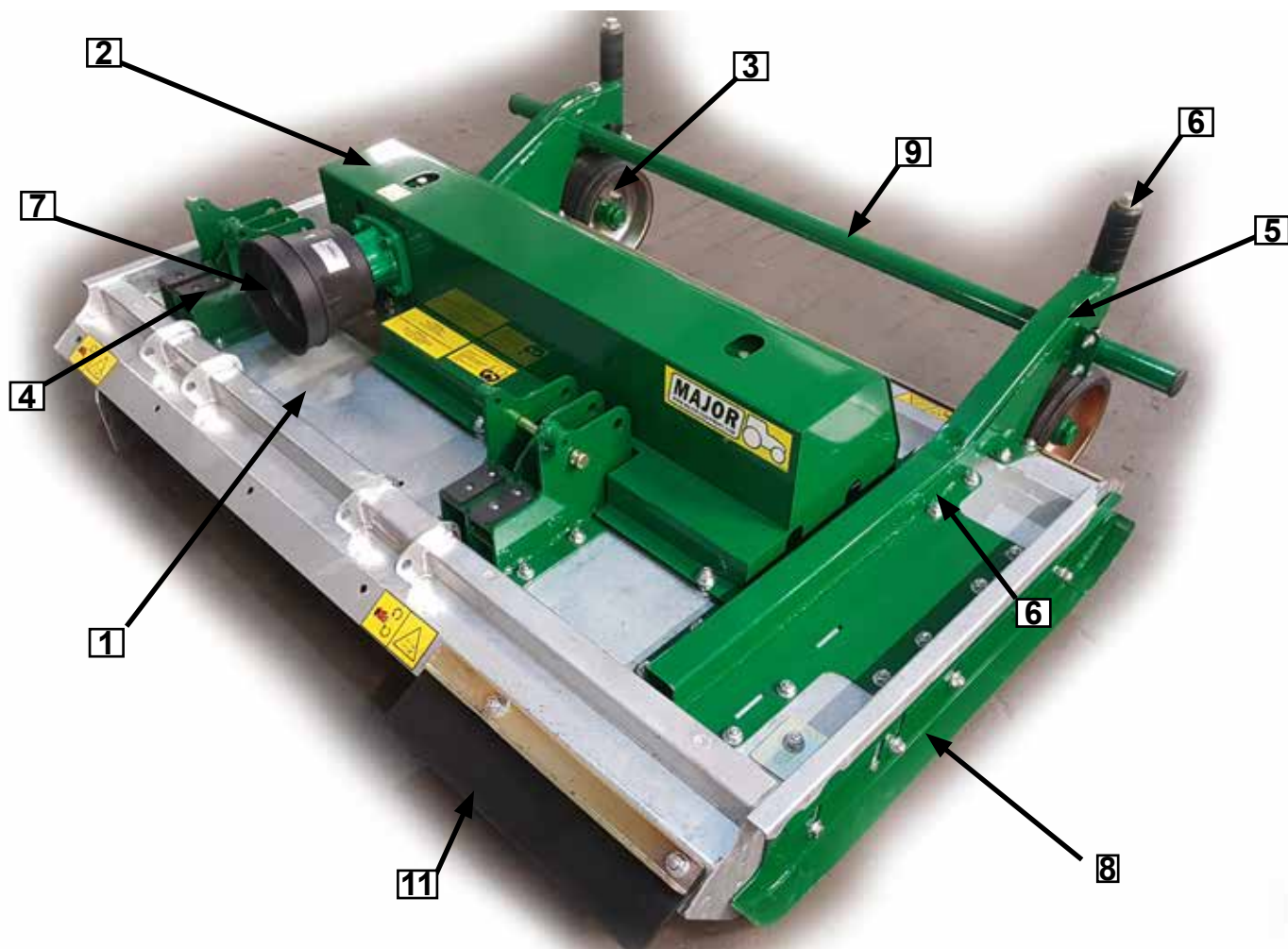

- | | |
|----|------------------------|
| 1 | Body |
| 2 | Drivetrain cover |
| 3 | Castor wheel |
| 4 | Linkage arm |
| 5 | Castor wheel bracket |
| 6 | Adjustable castor yoke |
| 7 | Gearbox PTO cover |
| 8 | Skid |
| 9 | Bull bar |
| 10 | Front guard |
| 11 | Rear guard |

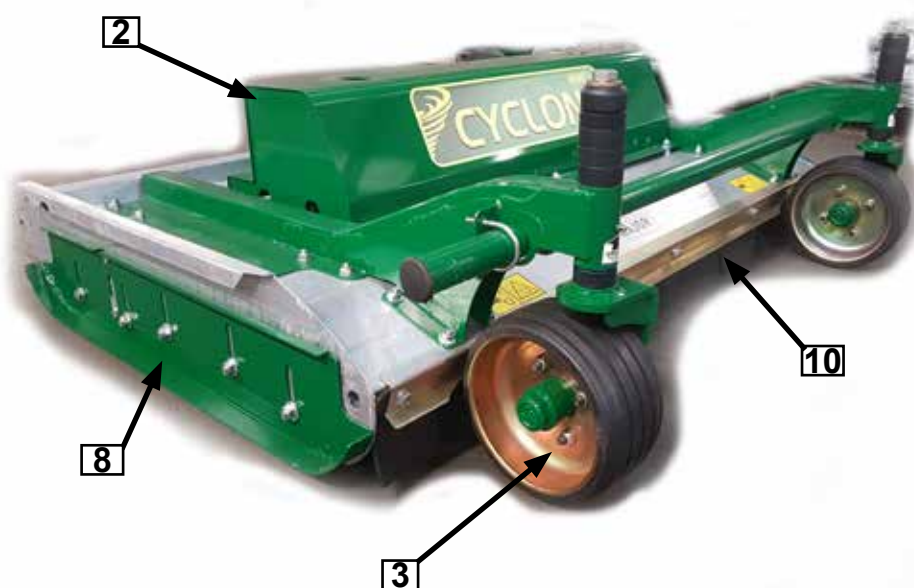

Inspections before Use



Always disengage PTO, Switch off tractor engine and engage the parking brake before making adjustments to the machine.

1. With the whole machine as level as possible, check the oil level in the Primary and Rotor Gearboxes and top up as required with recommended gear oil through the oil filler plug indicated. The correct level is at the oil level plug indicated.

Primary gearbox (MJ40)

Rotor gearbox (LF205)

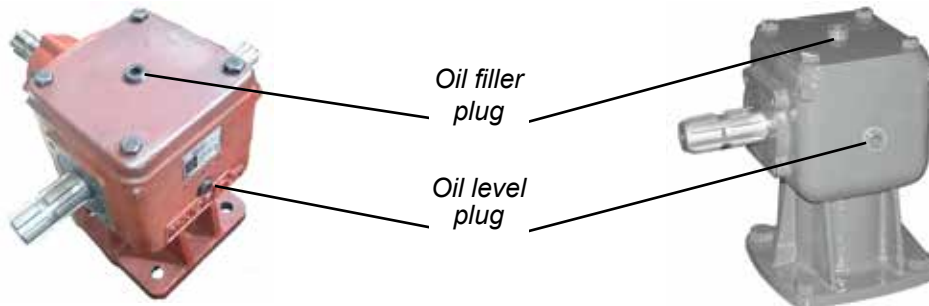

2. Grease the PTO shaft universal joints, drive shaft bearing and carrying arm pivots.
3. Check the blades for wear and damage and replace worn blades with new ones if required.
4. If the blade assembly is removed check the blade mounting ensure the gearbox shaft nut is tight and retained in place by split pin.

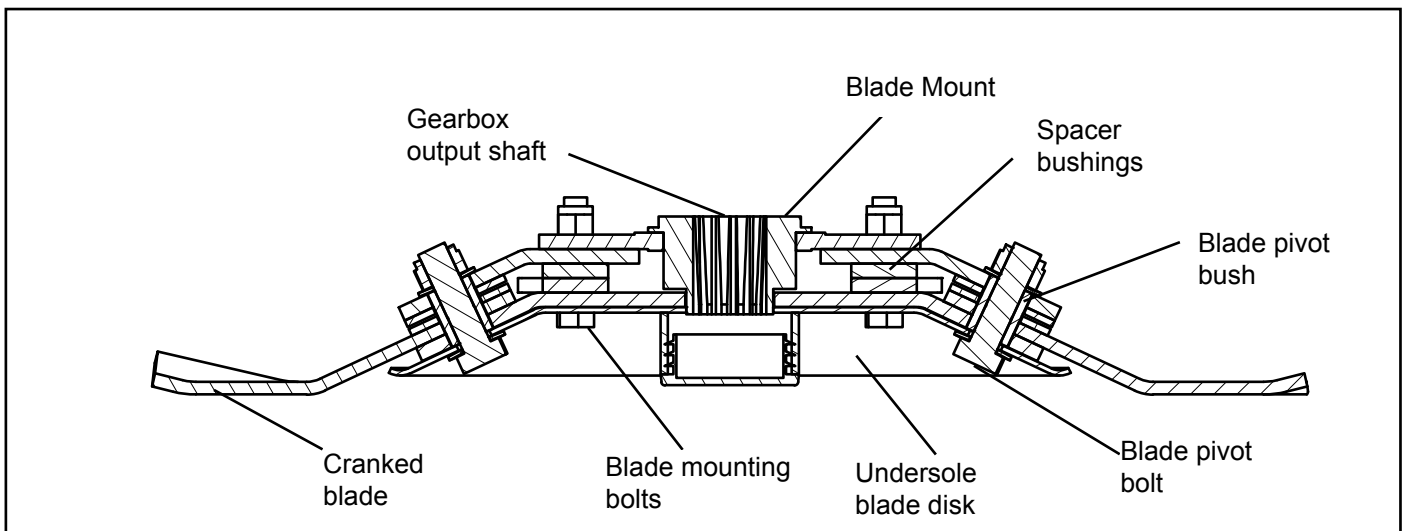

5. Check tightness of all nuts, bolts and retaining screws after the first and second hours of work.
6. Ensure safety guards and flaps are in place at all times where fitted. If these become worn or missing, replace them immediately with new ones.
7. Due to the corrosive nature of grass when cut, wash down the machine when finished mowing, especially when the machine is being stored for a long period of time.

Starting Regulations



Always check that any imminently dangerous conditions have been eliminated before using the machine. Ensure all guarding is present & the operator is fully aware of the operations of the machine.



Always ensure the pins lock the PTO shaft yoke ends onto the spline shafts on both the tractor and the implement. An unlocked shaft could slip out of position, causing notable mechanical damage and serious injury to both operator and bystanders.

Attaching the machine to the tractor



Always operate on level ground when attaching/detaching the machine. This will prevent dangerous movement. Never allow anyone to stand between the tractor and the machine.

1. With the machine located on the level ground drive in slowly and locate tractor arms 1 inside the linkage bracket 2.
2. Rest tractor arms 1 inside the linkage bracket 2 and secure the position with pin 3.
3. Before connecting the PTO shaft 4 to the tractor, check for length as previously described in this booklet.
4. Ensure PTO check chains 5 are anchored to prevent PTO guarding from rotating.
5. If the machine has hydraulic hoses connect them to the appropriate connection.

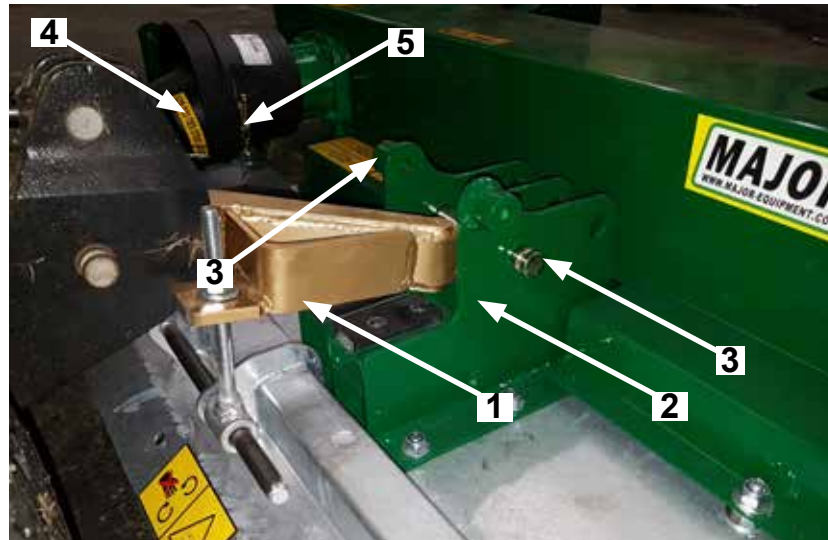

Height Adjustment bolts

Desired cutting height must be set by means of an adjustment bolt and secured by two locking nuts above and below the linkage arm.

This setup will also prevent the machine from flipping back during reversing. Failure to do so can expose the blades and damage the PTO shaft.



Ensure that the bolt doesn't come in contact with the tractor. It can be cut down if required (depending on the model of your tractor).

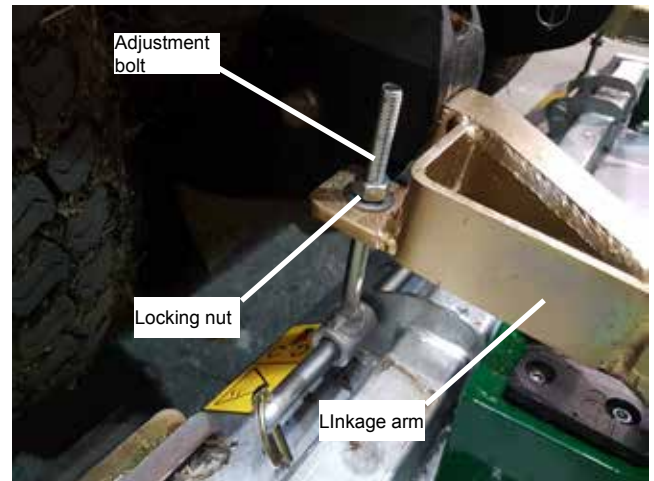

Transport Position



Before raising the machine wait until the transmission and the blades are completely still.



During the transport of the machine it is recommended that the PTO shaft is disconnected.

1. Check machine is hitched to the tractor as described. Ensure the tractor parking brake is applied
2. Ensure moving parts become still then transform the machine into transport position by hydraulic control
3. During the transport and any time the machine shall be raised, the raising device shall be adjusted to assure that the machine is 250mm over the ground.

Operating the Machine/Mowing



Never place limbs under the machine while rotors are turning. Rotors can remain turning for up to 1 minute after disengaging PTO.

1. While operating this machine the PTO input rate should not exceed the RPM stated in the Product Specifications section of this booklet. Always operate on level ground when connecting/disconnecting the implement. This will prevent dangerous movement.
2. Never allow anyone to stand between the tractor and the machine. Ensure the machine is attached correctly to the tractor as previously described.
3. Lower the machine on the ground and adjust the height of the castor wheels and the rear roller to the desired cutting height.
4. Start up the tractor PTO at a low RPM.
5. Build up to operating speed, select a suitable forward gear & proceed to cut grass.

Castor wheels and roller adjustment

In order to achieve desired cutting height, castor wheels and roller should be adjusted.

Castor wheels

To adjust the height of front wheels lift up the machine and:

1. Unscrew Bolt **A**;
2. Slide down the Castor Yoke **B** and remove it;
3. Depending on the desired cutting height place Spacers **C** above or below Castor Arm **D**.
4. When adjustment is complete, relocate Castor Yoke **B** and secure it by tightening Bolt **A**.
5. Repeat this procedure for the other wheel.

Roller (optional)

To adjust the height of the roller follow this procedure at both sides of the roller:

1. Loosen Bolt **A** (Note: You do not have to remove this bolt, half of the turn will suffice to allow movement);
2. Turn the Adjuster Nut **B** clockwise to increase the cut height or anti-clockwise to decrease the cut height;
3. Match the height of the roller on both sides of the machine by checking the position of Arrow **C**;
4. When adjustment is complete, secure the position of the Adjuster Rod **D** by fastening Bolt **A**.

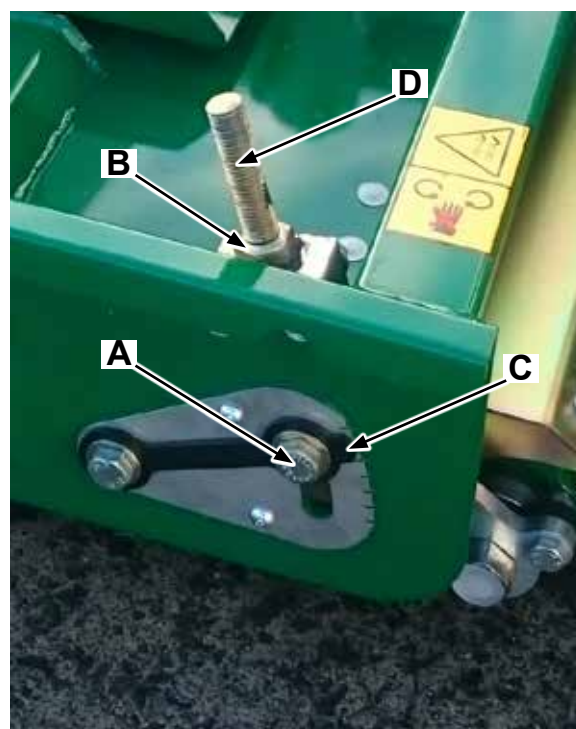
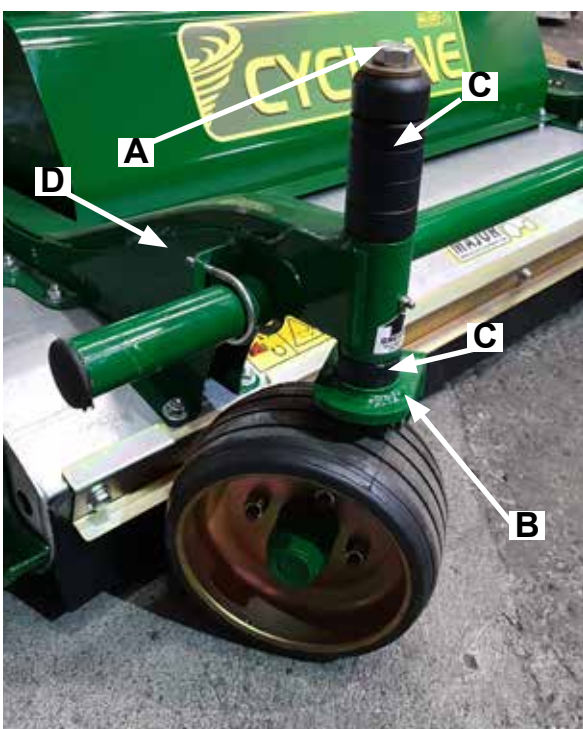

Skid adjustment

Both skids must be adjusted together with Castor Wheels as described previously. Skids also act as a safety guard and foot protection.

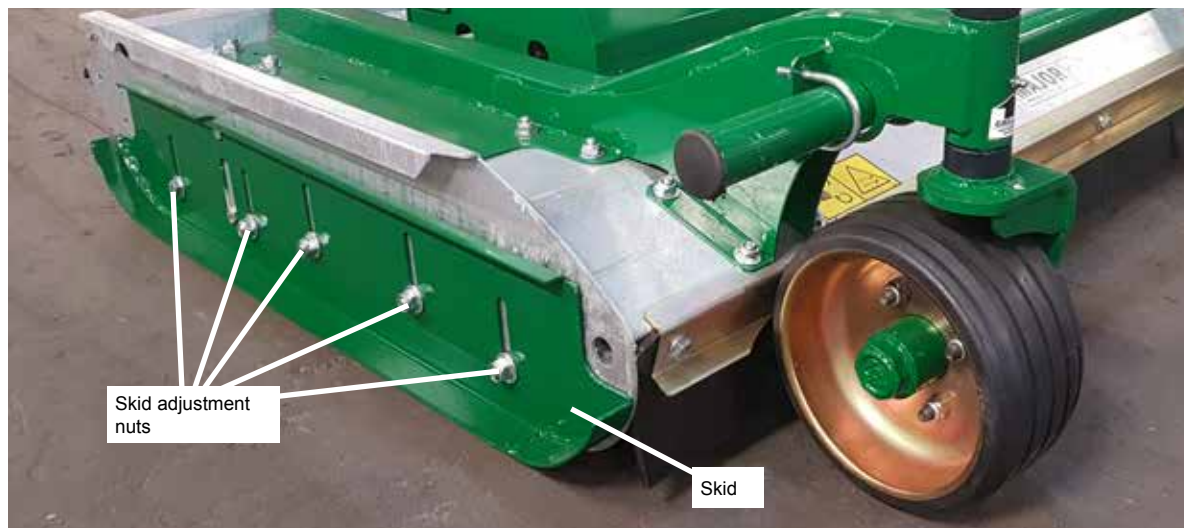

AVANT hydraulic attachment

Please see separate sheet provided with this manual for hydraulic hoses connection information.

With the tractor linkage arm in lowered position and the machine set on level ground make sure that the linkage bolt is located in the middle of the slotted hole.

Ensure that there is space between the machine and the linkage arms. Avoid “bulldozing” the ground.

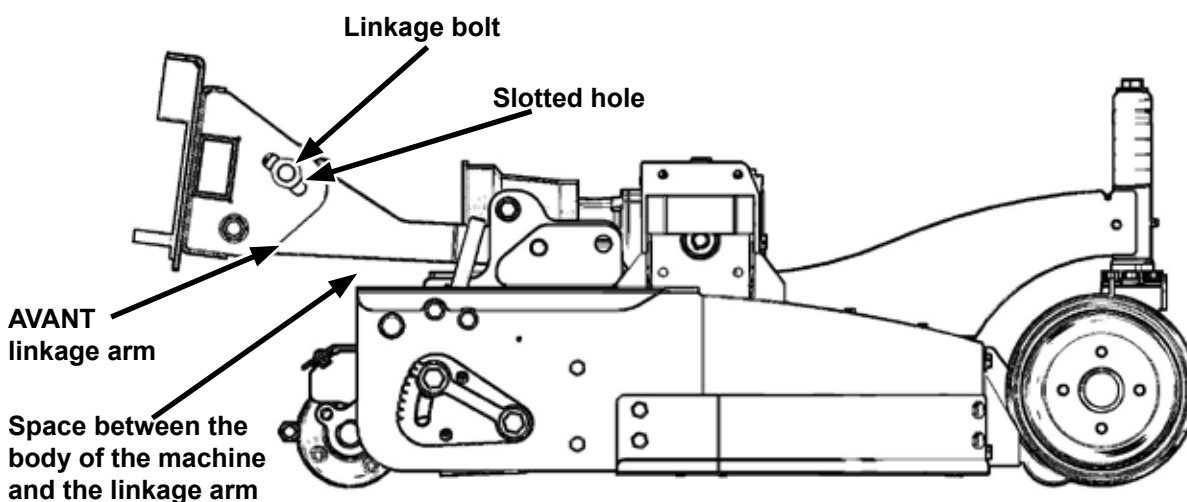

Maintenance

In order to keep your Major machine in a good working order it is necessary to conduct maintenance on a regular basis. Only competent and skilled persons who have fully read and understood this operator's manual are allowed to carry out maintenance on this machine. It is important to replace worn parts immediately with genuine Major spare parts. These parts are manufactured to the same specification as the machine and will provide the best result. Genuine Major spares can be obtained from MAJOR or your local MAJOR dealer.

All maintenance checks and operations must be carried on a firm level ground. The machine must always be disconnected from the tractor before any cleaning, lubricating and servicing operations can be carried out. If works must be carried out under the machine, ensure that the props, jacks, stands, hoists or cranes are capable of supporting the machine securely.

If emergency operations are required whilst the machine is connected to the tractor, switch off the engine of the tractor, remove the key from the ignition, engage the parking brake and disengage the PTO. An example of such emergency situation is the complete blockage of the machine in the field. To clear out the blockage follow the safety steps described above and clear out the blockage. Ensure there are no ropes, twines or wires wrapped around the rotors.

Machine storage

To prolong the life of your machine it is recommended to store it in a dry environment. Prior to parking the machine for storage, wash the machine thoroughly, especially underneath, and ensure that there is no grass or debris left on the machine. Lubricate all pivot points with EP2 type grease. Check for oil leaks and fix these if required. Any parts of the machine with damaged paint/galvanised surface must be painted.

PTO Shaft Maintenance

Guard Removal and Yoke End Greasing

1. Prise back locking tabs
2. Pull back PTO Guard
3. Grease points as shown
4. Push Guard into position
5. Click into place
6. Tie check chain

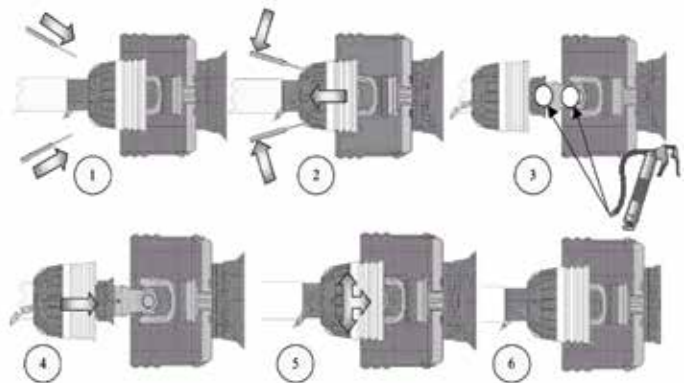

PTO Greasing Intervals

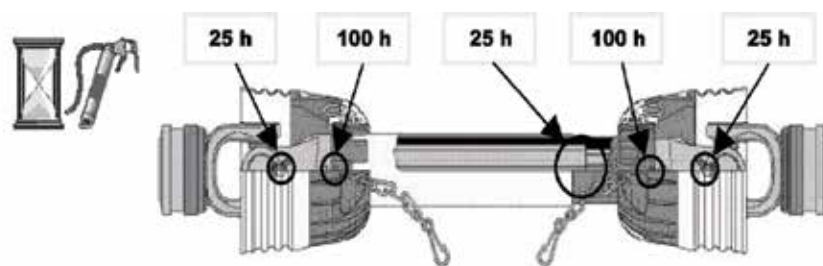

Shearbolt Replacement (if applicable)

1. Slide yoke shield back.
2. Drive out sheared bolt with hammer and punch.
3. Align holes and install new shear bolt. (Use only genuine MAJOR replacement shear bolts)
4. Slide yoke shield securely in place



Always fit PTO shaft with the shearbolt/slip-clutch end connected to the machine as directed on the PTO guarding.

Maintenance of other components

- All nuts and bolts in the transmission including Rubber couplings, Star Drives, PTO Shafts and Gearboxes should be checked for tightness after mowing at the following intervals:
 - 1st 40 hours
 - 1st 100 hours
 - 1st 250 hours
 - And every 250 hours thereafter.
- Check blades on a regular basis for wear. Replace any damaged or worn parts immediately.

Rollers (if applicable)

Check the condition of the roller ends (stub axle end) at the end of every season. The shaft (stub axle shaft) must be able to rotate freely and without excessive play. If necessary, remove the roller end and adjust the tightness of the bearings.

Replacement of wear parts

Blades, blade backs, blade bushing, blade bolts and nuts must be checked on a regular basis for wear and deflection. MAJOR recommends to visually check the blade assemblies every 40 hours of operation. This interval may change depending on the operational conditions.

Replace any damaged or worn parts immediately, failure to do so can result in blade breakages and can cause damage to the equipment or injuries to the operator and others nearby.

Blunt blades must be sharpened or replaced, failure to do so will result in a poor quality cut and excessive use of power from your tractor.

Blade Rotation



Ensure blade rotation and timing (90 degrees) is correct after servicing transmission. See diagrams below.

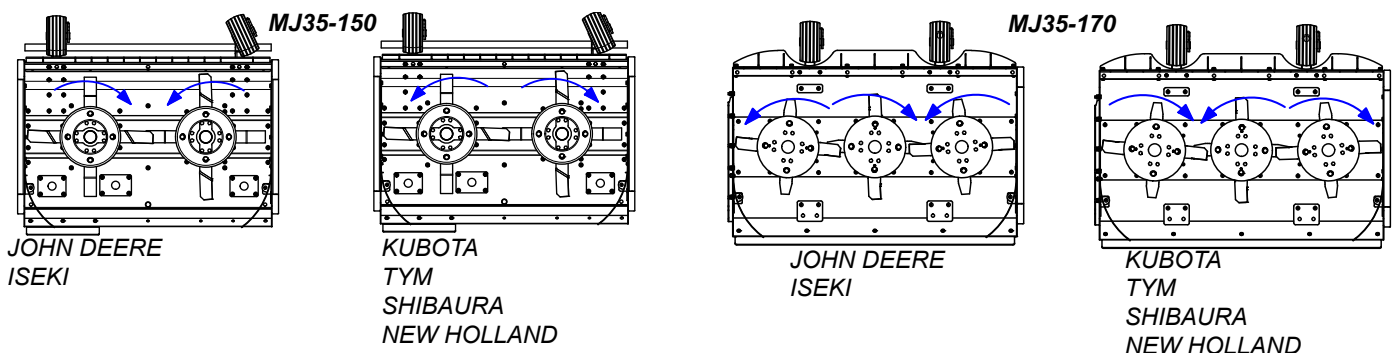

Blade rotation viewed from underside

Lubrication schedule

Use EP2 type grease or equivalent.

Replace oil in gearboxes after first 100 hours

Use oil which conforms to 80W/90 standards.

	Initially	8 hours	40 hours	80 hours	400 hours
All PTO Shaft Yoke Ends	●	●			
PTO tubes	●			●	
Roller height adjuster		●			
Roller		●			
Castor wheel pivot				●	
Castor wheel axle				●	
Check oil levels in the gearboxes				●	
Replace oil in gearboxes					●

Clearing out a blockage



Always wear appropriate PPE when clearing out blockages.

If blockage of blades occurs proceed as follows:

1. Set the machine into transport position (including the top links);
2. Park the tractor on level ground, switch off the engine and remove the key from the ignition;
3. Apply a handbrake and disconnect the PTO shaft;
4. Using a pressure washer clear out the excess material built up around the blades. If the pressure washer is not available use your hand to remove the grass from around the blades, bearing in mind that there might be wires wrapped up around the rotors.

Troubleshooting

Fault	Cause	Remedy
Leaves a streak of uncut or partially cut grass	Blades dull or bent	Replace blades
	Carrier RPM too low	Use correct PTO speed
	Field conditions are so wet that the wheels are pushing grass into mud	Too wet to mow. Stop operation and wait until it is drier
	Ground speed too fast	Reduce ground speed by shifting to a lower gear
	Grass is down from previous weather conditions	Mow in only one direction
	Possible build-up materials under machine	Clean the machine
Material discharges from machine unevenly; bunches of material along with swath	Blades mounted incorrectly (cutting edge against direction rotation)	Change blades so that cutting edge is facing correct rotation
	Material too high and too much material	Reduce ground speed but maintain recommended rpm at tractor PTO or make two passes over material. Raise machine for the first pass and lower to desired height for the second and cut a 90 degree angle to first pass
Gearbox overheating	Grass wet	Allow grass to dry before mowing. Slow ground speed of tractor but keep engine running at full PTO rpm. Cutting lower will help
	Low on lubricant	Fill to proper level
Blade is scalping ground	Improper type lubricant	Replace with proper lubricant
	Excessive grass/debris build-up around gearbox. PTO running too fast.	Remove grass, etc from machine. Lower the RPM rate
Blade is scalping ground	Machine too low	Raise machine - reset wheels
	Field is ridged	Cut field at a different angle
	Field is too wet	Stop and wait until it is dried

Blades wear too fast	Cutting in sandy conditions	Increase cutting height
	Cutting in rocky conditions	Increase cutting height
	Blades hitting the ground	Increase cutting height
Machine seems to require excessive power	Advancing into grass too rapidly	Reduce forward travel speed
	Hitting ground	Raise machine and reset wheels
	Worn or dull blades	Sharpen or replace blades
Excessive vibration	Check gearbox bolts	Tighten if loose
	Check for loose nuts on blades	Tighten if loose
	Blade broken	Replace blades, in set
	New blade or bolts matched with worn blade or bolts	Replace blades or bolts in sets
	Drivelines not phased correctly. Implement and tractor yokes must be in line	Phase the driveline. Replace if necessary
Noisy machine	Low oil in gearbox	Check level and add oil
	Loose Parts	Check all bolts are fully tightened
	Wrong PTO rpm rate	Check PTO rate & adjust as necessary
	Rotors bent/broken	Replace bent or missing blades
	Bent PTO shaft	Check PTO shaft aligned correctly
	Bent gearbox shaft	Check output shaft on gearboxes are not bent
		Check driveline between gearboxes is aligned
Gearbox leaking	Damaged oil seal	Replace seal
	Bent shaft	Replace oil seal and shaft
	Shaft rough in oil seal area	Replace or repair shaft
	Oil seal installed incorrectly	Replace seal
	Oil seal not sealing in the housing	Replace seal or use a sealant on outside diameter of seal
	Oil level too high	Drain oil to proper level
	Hole in gearbox	Replace the gearbox
	Gasket damaged	Replace gasket
	Bolts loose	Tighten bolts

Spare Parts - MJ35

MJ35-150 Cyclone Mower

120419

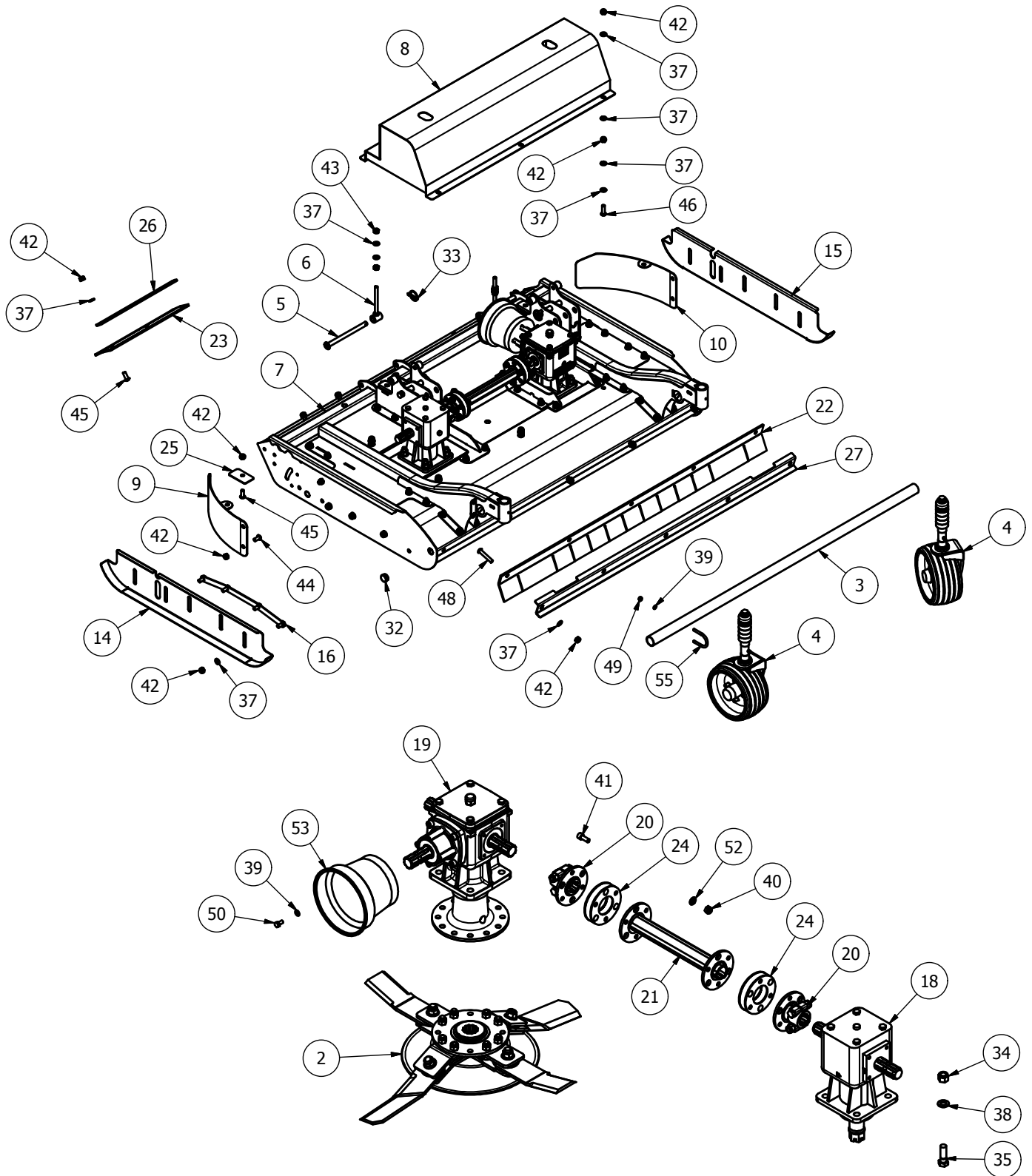

MJ35-150 Parts List

Item	Part No.	Description	Qty
1	775-DCBLDTX-L	775mm X-BLADE Anti-Cik	1
2	775-DCBLDTX-R	775mm X-BLADE Cik	1
3	MJ35-150-LK26	GUARD TUBE	1
4	RM2-CW-GA01	SYNERGY CASTOR ASSEMBLY	2
5	TFM-SHIB-10	HEIGHT BAR	2
6	TFM-SHIB-15	HEIGHT ADJUSTER	2
7	MJ35-150-BD01	150 CYCLONE BODY	1

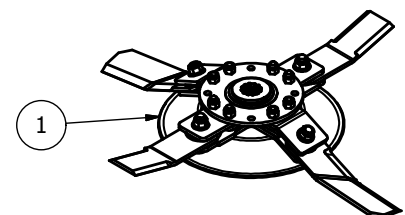

MJ35-150

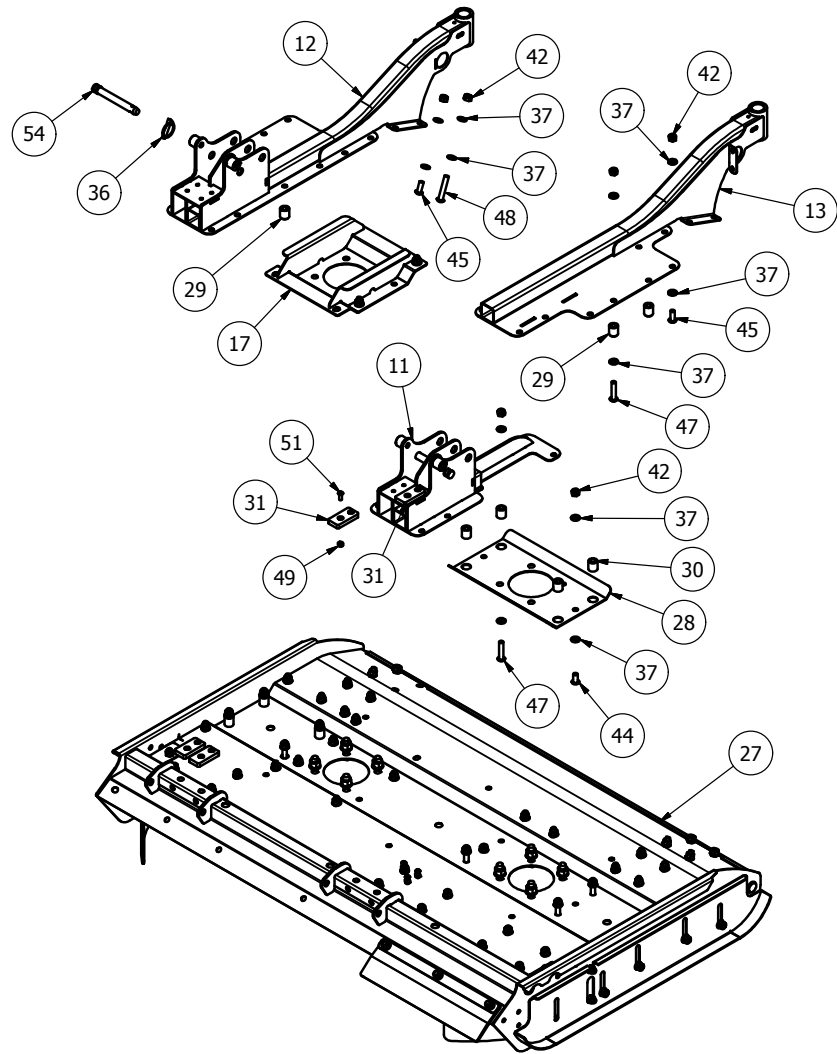

MJ35-150 Parts List (Continued)

8	MJ35-150-CVR01	GEARBOX COVER	1
9	MJ35-150-DF01	DEFLECTOR (NO ROLLER)	1
10	MJ35-150-DF01H	DEFLECTOR (NO ROLLER)	1
11	MJ35-150-LK01	CENTER LINKAGE	1
12	MJ35-150-LK20	LINKAGE CASTOR ARM	1
13	MJ35-150-LK40	CASTOR ARM	1
14	MJ35-150-SK01	SKID (RH FULL)	1
15	MJ35-150-SK01H	SKID (LH FULL)	1
16	MJ35-150-SK20	SKID CLAMP	2
17	MJ35-150-TR05	MAIN BOX TROUGH	1
18	LF205T	6 SPLINE 'T' BOX RATIO 1.47	1
19	MJ40T4W1147	MJ40 4-WAY BOX	1
20	DRV-6S-SY60	6 SPLINE 60mm DRIVE	2
21	DRV-RC-CYC150	MJ35-150 DRIVE	1
22	MJ35-150-GRD10	RUBBER FLAP (FRONT)	1
23	MJ35-150-GRD15	RUBBER FLAP	1
24	RM2-DRV	90mm PCD COUPLING	2
25	MJ35-150-DF04	DEFLECTOR MOUNT	2
26	MJ35-150-GRD16	RUBBER CLAMP (REAR)	1
27	MJ35-150-GRD11	RUBBER CLAMP (FRONT)	1
28	MJ35-150-TR01	TROUGH REINF'	1
29	MJ35-150-LK50	LINKAGE BUSH	6
30	MJ35-150-TR07	TROUGH BUSH	4
31	RM2-L018	Nylon Buffer	4

32	111044	DIA 26-30mm INSERT	5
33	37	LINCH PIN DIA 6	2
34	5/8F	5/8" FINE NYLOC NUT	8
35	58x2FBZP	5/8"x2" FINE BOLT	8
36	AN099/10	LINCH PIN DIA 9.5	2
37	FWM12	M12 FLAT WASHER	152
38	FWM16	M16 FLAT WASHER	8
39	FWM8	M8 FLAT WASHER	8
40	M10	M10 NYLOC NUT	12
41	M10x25SKS	M10x25mm SOC CAP HEAD 12.9 ZP	12
42	M12	M12 NYLOC NUT	88
43	M12HEX	M12 PLAIN NUT	4
44	M12x25SKBH	M12x25 SOCKET BUTTON HEAD 10.9	6
45	M12x30SKBH	M12x30 SOCKET BUTTON HEAD 10.9	43
46	M12x40SKBH	M12x40 SOCKET BUTTON HEAD 10.9	6
47	M12x55SKBH	M12x55 SOCKET BUTTON HEAD 10.9	10
48	M12x70SKBH	M12x70 SOCKET BUTTON HEAD 10.9	9
49	M8	M8 NYLOC NUT	12
50	M8x16SZP	M8x16 SET BOLT	4
51	M8x20SKBH	M8x20 SOCKET BUTTON HEAD 10.9	8
52	NL10SP	M10 SP NORDLOCK	12
53	NT20A	PTO GUARD (RND)	1
54	S77	CAT 1 PIN DIA 19x127mm	2
55	S8880-A	M8xDIA 50 U-BOLT	2

MJ35-170 Cyclone Mower

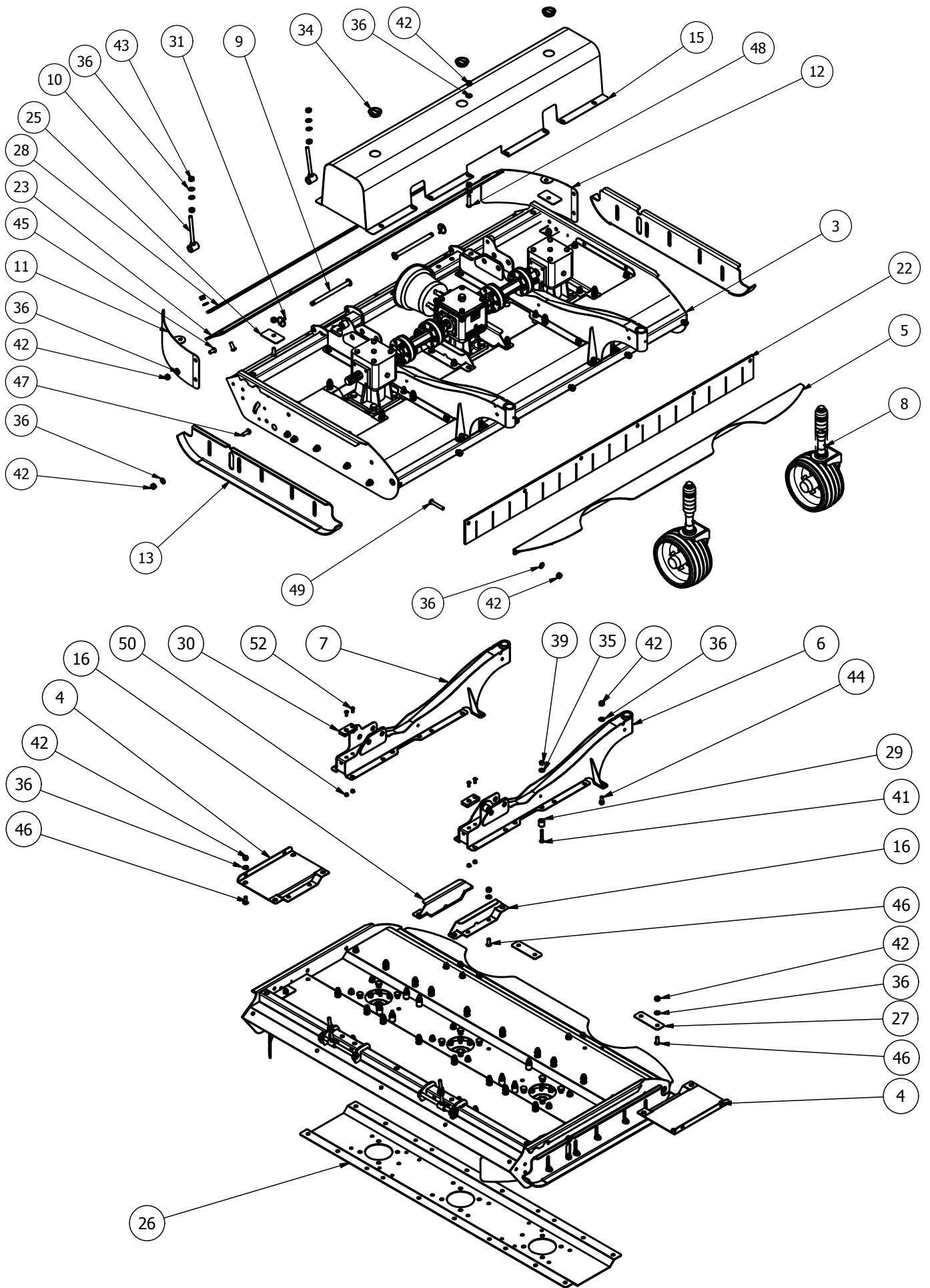

MJ35-170

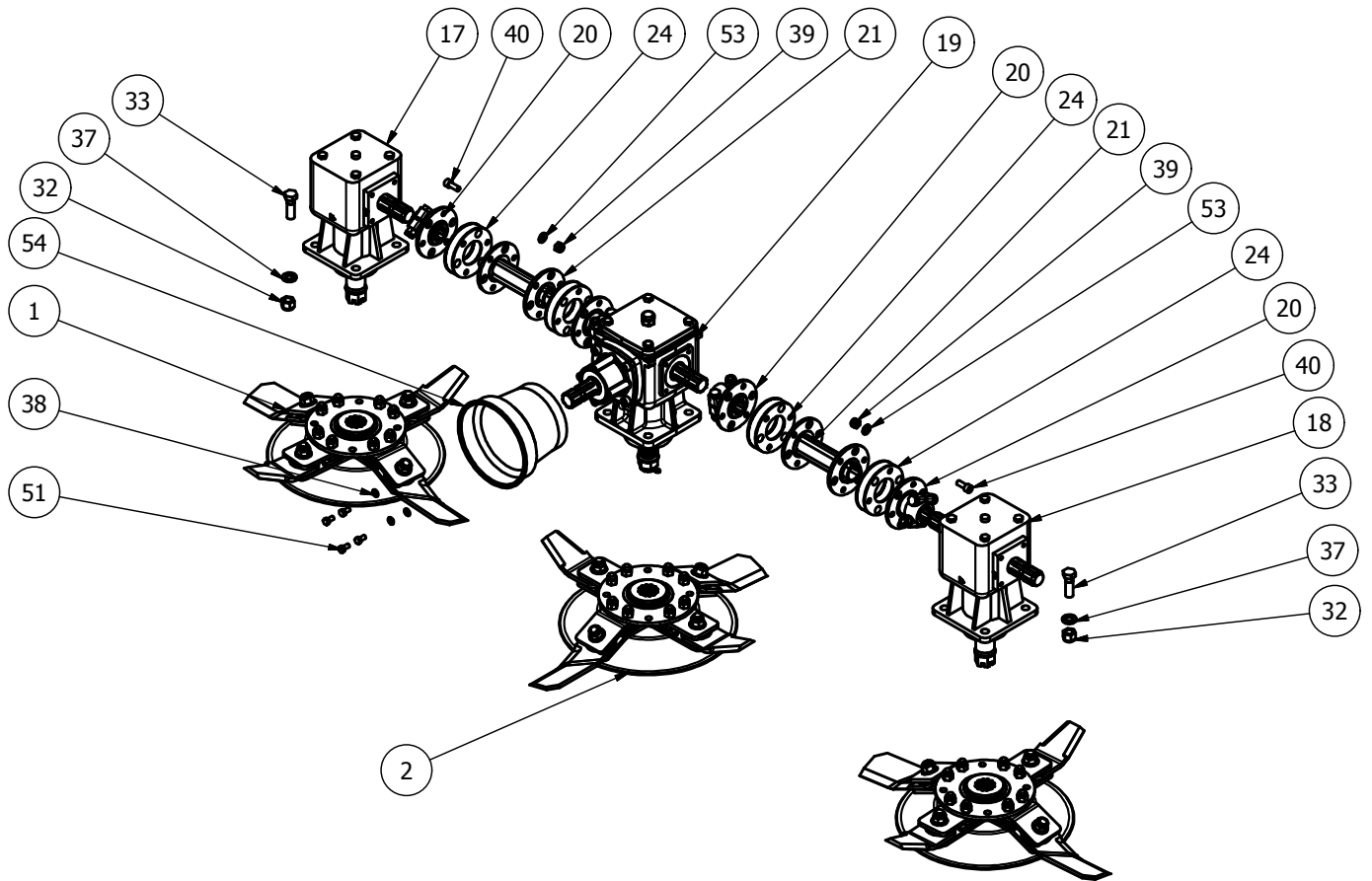

MJ35-170 Parts List

Item	Part No.	Description	Qty
1	640-DCBLDTXS-L	640mm SHORT X-BLADE Anti-Clk	2
2	640-DCBLDTXS-R	640mm SHORT X-BLADE Clk	1
3	MJ35-170-BD01	Main Deck WLDMT	1
4	MJ35-170-BD09	END TOUGH RIB	2
5	MJ35-170-GD01	FRONT GUARD	1
6	MJ35-170-LA01	LINKAGE/CASTOR ARM	1
7	MJ35-170-LA01H	REF MJ35-170-LA01	1
8	RM2-CW-GA01	SYNERGY CASTOR ASSEMBLY	2
9	TFM-SHIB-10	HEIGHT BAR	2
10	TFM-SHIB-15	HEIGHT ADJUSTER	2
11	MJ35-150-DF01	DEFLECTOR (NO ROLLER)	1
12	MJ35-150-DF01H	DEFLECTOR (NO ROLLER)	1
13	MJ35-150-SK01	SKID (RH FULL)	1
14	MJ35-150-SK01H	SKID (LH FULL)	1
15	MJ35-170-CVR01	170 CYCLONE COVER (Geared)	1
16	MJ60-200-TR01	CENTER RIB	2
17	LF205	6 SPLINE 'L' BOX RATIO 1.47	1
18	LF205T	6 SPLINE 'T' BOX RATIO 1.47	1
19	MJ40T4W1147	MJ40 4-WAY BOX	1
20	DRV-6S-SY60	6 SPLINE 60mm DRIVE	4
21	DRV-RC-SY170	MJ60-170 DRIVE	2
22	MJ35-170-RG01	8mm RUBBER FLAP	1
23	MJ35-170-RG02	RUBBER FLAP	1
24	RM2-DRV	90mm PCD COUPLING	4
25	MJ35-150-DF04	DEFLECTOR MOUNT	2
26	MJ35-170-BD07	CENTRE UNDER TRAY SUPPORT	1
27	MJ35-170-BD08	UNDER LINKAGE TAB	2
28	MJ35-170-GD04	RUBBER CLAMP (REAR)	1
29	MJ35-170-LA06	SPACER BUSH	8
30	RM2-L018	Nylon Buffer	2
31	37	LINCH PIN DIA 6	2
32	5/8F	5/8" FINE NYLOC NUT	12
33	58x2FBZP	5/8"x2" FINE BOLT	12
34	CP176-181MG1	45mm INSERT	3
35	FWM10	M10 FLAT WASHER	8
36	FWM12	M12 FLAT WASHER	85
37	FWM16	M16 FLAT WASHER	12
38	FWM8	M8 FLAT WASHER	4
39	M10	M10 NYLOC NUT	32
40	M10x25SKS	M10x25mm SOC CAP HEAD 12.9 ZP	24
41	M10x60SKBH	M10x60 SOCKET BUTTON HEAD 10.9	8
42	M12	M12 NYLOC NUT	83
43	M12HEX	M12 PLAIN NUT	4
44	M12X25SK	M12x25 SOCKET HEAD SCREW	4
45	M12x25SKBH	M12x25 SOCKET BUTTON HEAD 10.9	4
46	M12x30SKBH	M12x30 SOCKET BUTTON HEAD 10.9	27
47	M12x30SZP	M12x30 SET BOLT	10
48	M12x50SKBH	M12x50 SOCKET BUTTON HEAD 10.9	16
49	M12x70SKBH	M12x70 SOCKET BUTTON HEAD 10.9	6
50	M8	M8 NYLOC NUT	4
51	M8x16SZP	M8x16 SET BOLT	4
52	M8x20SKBH	M8x20 SOCKET BUTTON HEAD 10.9	4
53	NL10SP	M10 SP NORDLOCK	24
54	NT20A	PTO GUARD (RND)	1

Wheel assembly (RM2-CW-GA01) (MJ35 and MJ61 models)

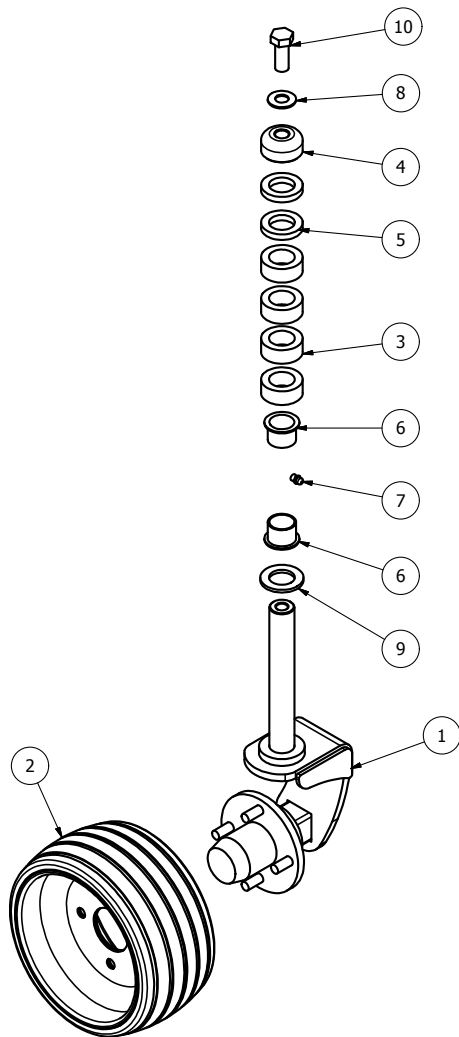

Item	Part No.	Description	Qty
1	RM2-CWY	CASTOR WHEEL MOUNT	1
2	MJCW-GS-GA	MOULDED RUBBER WHEEL	1
3	RM2-L019	HEIGHT ADJUSTOR NYLON	4
4	RM2-L020	CASTOR TOP	1
5	RM2-L021	1/2 HEIGHT ADJUSTOR NYLON	2
6	3026DU	30x34x26 FLANGE BUSH	2
7	851	GREASE NIPPLE M8x1.25 STR	1
8	DSW34	DISC SPRING 34x16.3 x2	1
9	FWM30	M30 FLAT WASHER	1
10	M16x40SZP	M16x40 SET BOLT	1

PTO shafts (MJ35)

Tractor	PTO shaft	Tractor	PTO shaft
JOHN DEERE	S2D052CES54001	SHIBAURA & NEW HOLLAND	S1D033CES54001
ISEKI	S1D033CES60001	TYM	T401060CEC12B02
KUBOTA	S2D036CES57001		

Tractor Linkage arms (MJ35 and MJ61 models)

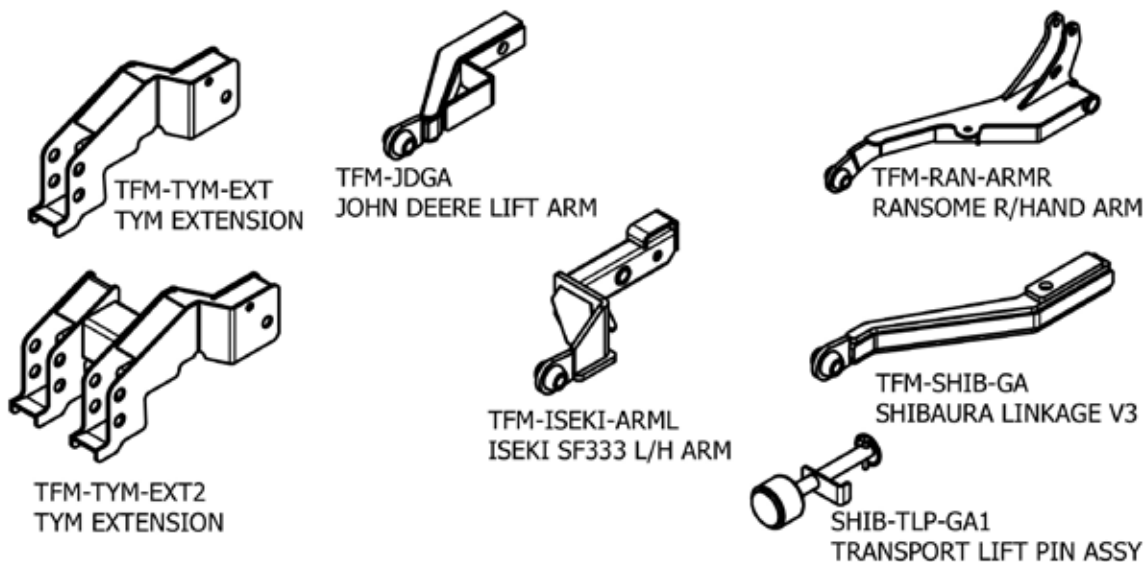

MJ35 Blades

775-DCBLDTX-L TYPE 1 (MJ35-150)

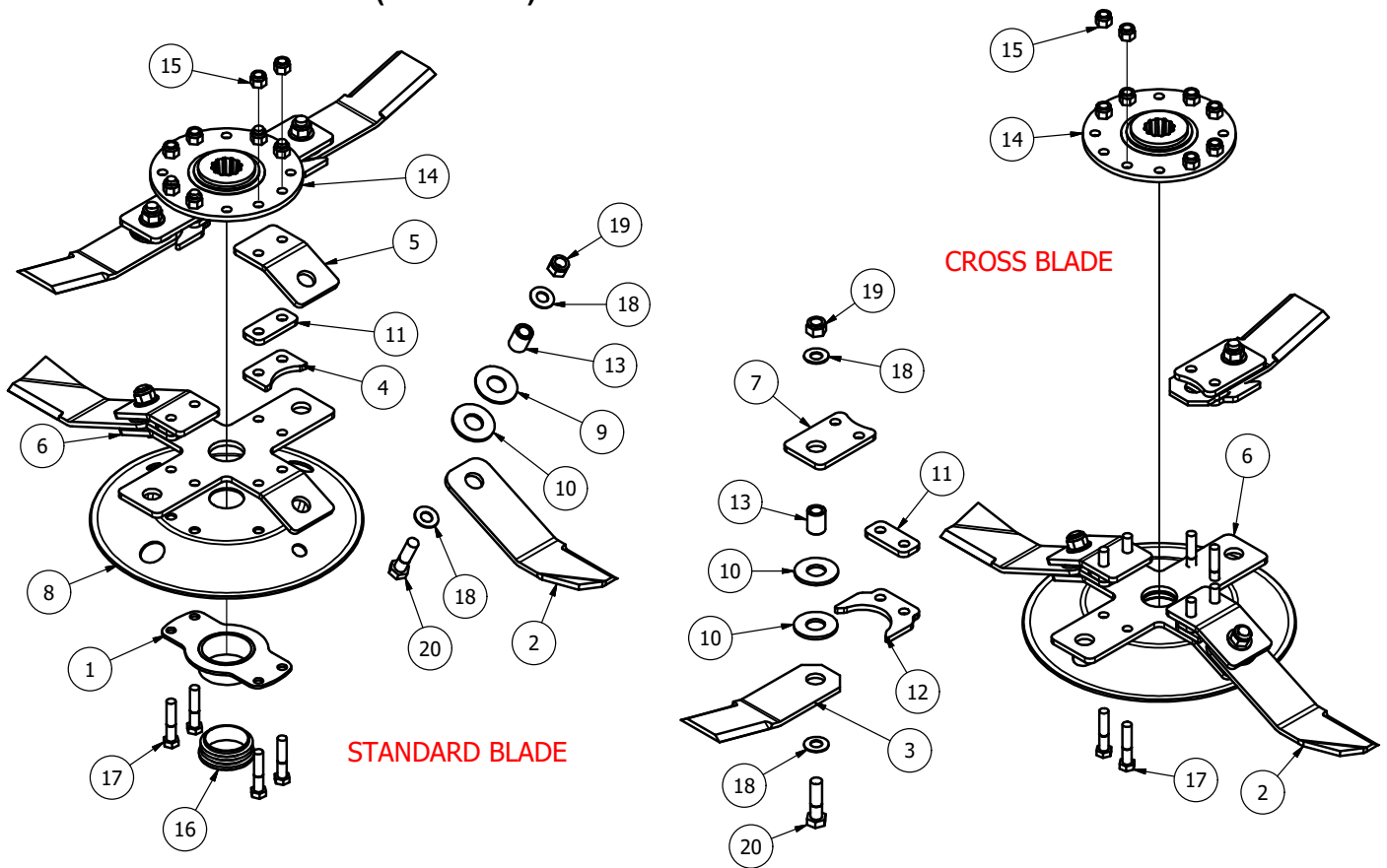

Item	Part No.	Description	Qty
1	DISC-315-25-10	ROTOR NUT CAP	1
2	BLD-28025-AC	BLADE 280xDia 25 (Anti-Clk)	2
3	BLD-28525-OVL	OVERLAP for BLADE 280xDia 25	2
4	BLDB-315-25-SY-STP1	BLADE STOP SPACER	2
5	BLDB-315-25-SY2	BLADE BACK (315 CTR 25 deg)	2
6	BLDBX-294-25-SY2	BLADE BACK (294 CTR 25 deg)	1
7	BLDBXT-315-30	OVERLAPPER MOUNT	2
8	DISC-315-25	DISC (315 BLADE 25 deg)	1
9	BLD-25025H-WSR3	3mmxDIA 26 BLADE WASHER	2
10	BLD-25025H-WSR4	4mmxDIA 26 BLADE WASHER	6
11	BLDB-315-25-SY2SP08	8mm SPACER	4
12	BLDB-CY150-STP1	BLADE STOP SPACER	2
13	BB25-16-32	BLADE BUSH	4
14	RM2-BMAX-MK2	BLADE MOUNT RM2	1
15	1/2F	1/2" FINE NYLOC NUT	8
16	111072	DIA 66-72mm INSERT	1
17	12x212FBZP	1/2"x2 1/2" FINE BOLT	8
18	DSW34	DISC SPRING 34x16.3x2	8
19	M16	M16 NYLOC NUT	4
20	M16x60BZP	M16x60 BOLT	4

1 off MJ35-150

775-DCBLDTX-R TYPE 1 (MJ35-150)

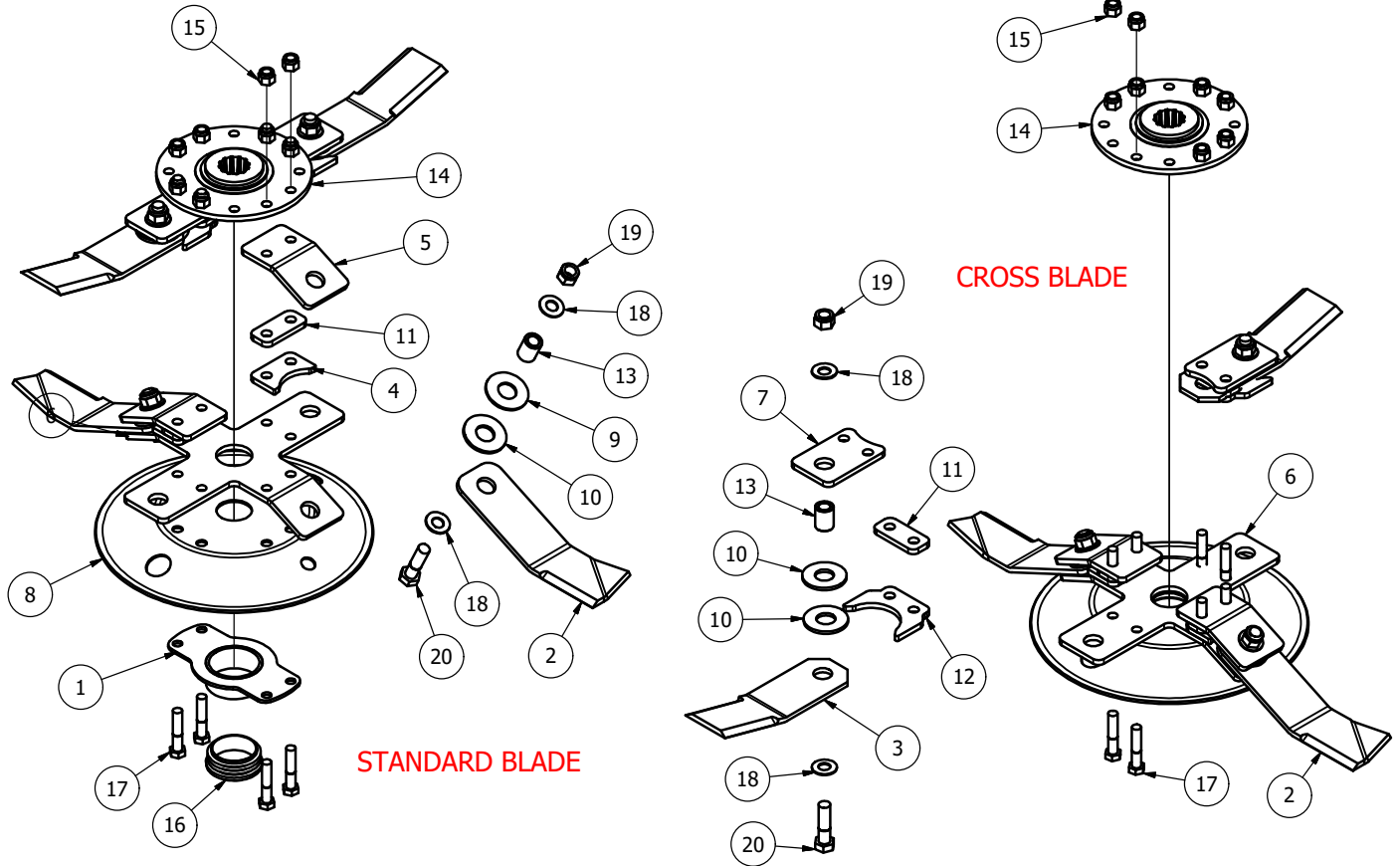

Item	Part No.	Description	Qty
1	DISC-315-25-10	ROTOR NUT CAP	1
2	BLD-28025-C	BLADE 280xDia 25 (Clk)	2
3	BLD-28525-OVL	OVERLAP for BLADE 280xDia 25	2
4	BLDB-315-25-SY-STP1	BLADE STOP SPACER	2
5	BLDB-315-25-SY2	BLADE BACK (315 CTR 25 deg)	2
6	BLDBX-294-25-SY2	BLADE BACK (294 CTR 25 deg)	1
7	BLDBXT-315-30	OVERLAPPER MOUNT	2
8	DISC-315-25	DISC (315 BLADE 25 deg)	1
9	BLD-25025H-WSR3	3mmxDIA 26 BLADE WASHER	2
10	BLD-25025H-WSR4	4mmxDIA 26 BLADE WASHER	6
11	BLDB-315-25-SY2SP08	8mm SPACER	4
12	BLDB-CY150-STP1	BLADE STOP SPACER	2
13	BB25-16-32	BLADE BUSH	4
14	RM2-BMAX-MK2	BLADE MOUNT RM2	1
15	1/2F	1/2" FINE NYLOC NUT	8
16	111072	DIA 66-72mm INSERT	1
17	12x212FBZP	1/2"x2 1/2" FINE BOLT	8
18	DSW34	DISC SPRING 34x16.3x2	8
19	M16	M16 NYLOC NUT	4
20	M16x60BZP	M16x60 BOLT	4

1 off MJ35-150

775-DCBLDTX-L TYPE 2 (MJ35-150)

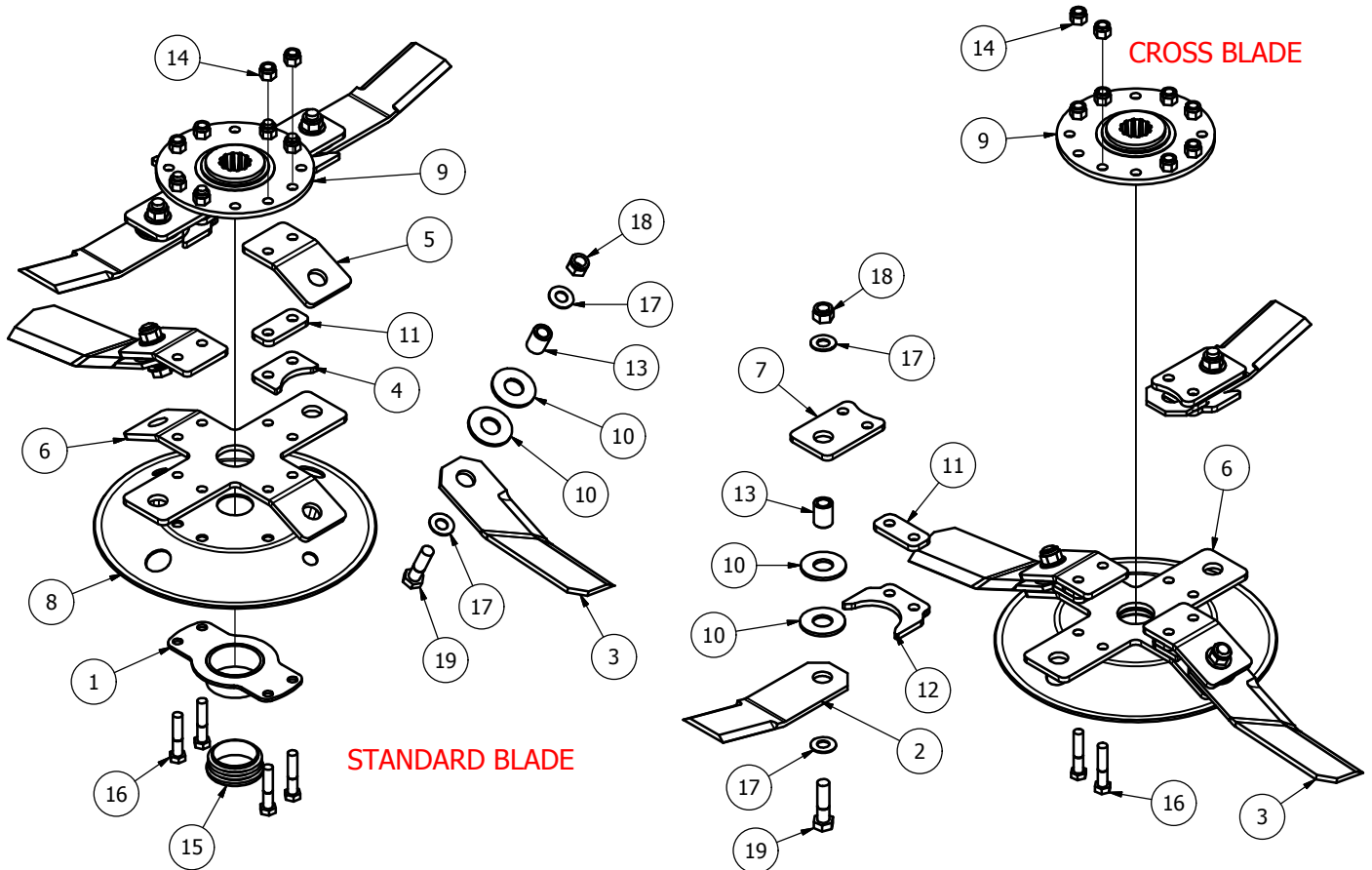

Item	Part No.	Description	Qty
1	DISC-315-25-10	ROTOR NUT CAP	1
2	BLD-28525-OVL	OVERLAP for BLADE 280xDia 25	2
3	BLD-SY15-AC	Twist Blade 280xDia 25 (Anti_Clk)	2
4	BLDB-315-25-SY-STP1	BLADE STOP SPACER	2
5	BLDB-315-25-SY2	BLADE BACK (315 CTR 25 deg)	2
6	BLDBX-294-25-SY2	BLADE BACK (294 CTR 25 deg)	1
7	BLDBXT-315-30	OVERLAPPER MOUNT	2
8	DISC-315-25	DISC (315 BLADE 25 deg)	1
9	RM2-BMAX-MK2	BLADE MOUNT RM2	1
10	BLD-25025H-WSR4	4xDIA 26 BLADE WASHER	8
11	BLDB-315-25-SY2SP08	8mm SPACER	4
12	BLDB-CY150-STP1	BLADE STOP SPACER	2
13	BB25-16-32	BLADE BUSH	4
14	1/2F	1/2" FINE NYLOC NUT	8
15	111072	DIA 66-72mm INSERT	1
16	12x212FBZP	1/2"x2 1/2" FINE BOLT	8
17	DSW34	DISC SPRING 34x16.3x2	8
18	M16	M16 NYLOC NUT	4
19	M16x60BZP	M16x60 BOLT	4

1 off MJ35-150

775-DCBLDTX-R TYPE 2 (MJ35-150)

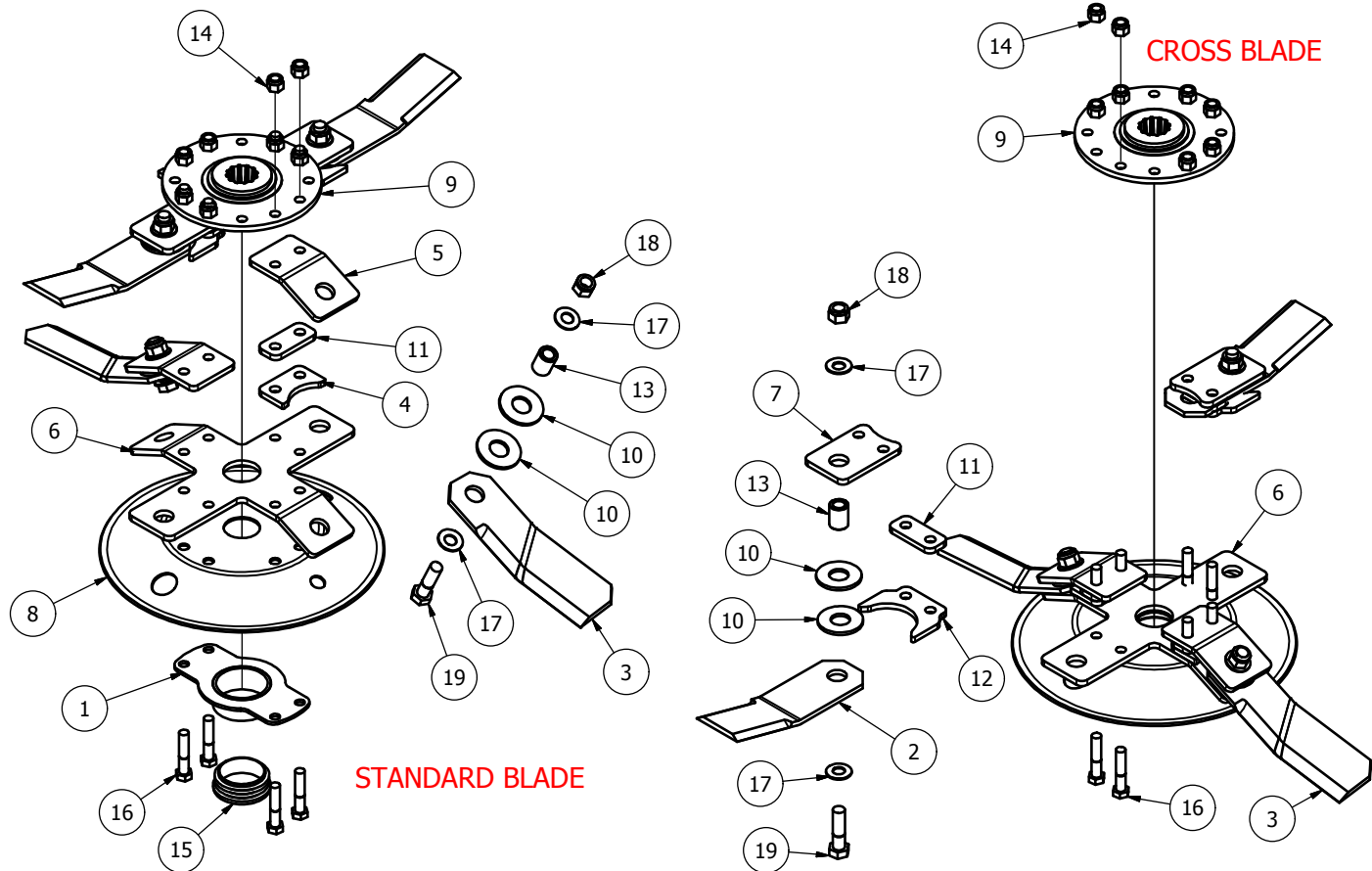

Item	Part No.	Description	Qty
1	DISC-315-25-10	ROTOR NUT CAP	1
2	BLD-28525-OVL	OVERLAP for BLADE 280xDia 25	2
3	BLD-SY15-C	Twist Blade 280xDia 25 (Clk)	2
4	BLDB-315-25-SY-STP1	BLADE STOP SPACER	2
5	BLDB-315-25-SY2	BLADE BACK (315 CTR 25 deg)	2
6	BLDBX-294-25-SY2	BLADE BACK (294 CTR 25 deg)	1
7	BLDBXT-315-30	OVERLAPPER MOUNT	2
8	DISC-315-25	DISC (315 BLADE 25 deg)	1
9	RM2-BMAX-MK2	BLADE MOUNT RM2	1
10	BLD-25025H-WSR4	4xDIA 26 BLADE WASHER	8
11	BLDB-315-25-SY2SP08	8mm SPACER	4
12	BLDB-CY150-STP1	BLADE STOP SPACER	2
13	BB25-16-32	BLADE BUSH	4
14	1/2F	1/2" FINE NYLOC NUT	8
15	111072	DIA 66-72mm INSERT	1
16	12x212FBZP	1/2"x2 1/2" FINE BOLT	8
17	DSW34	DISC SPRING 34x16.3x2	8
18	M16	M16 NYLOC NUT	4
19	M16x60BZP	M16x60 BOLT	4

1 off MJ35-150

640-DCBLDTXS-L (MJ35-170)

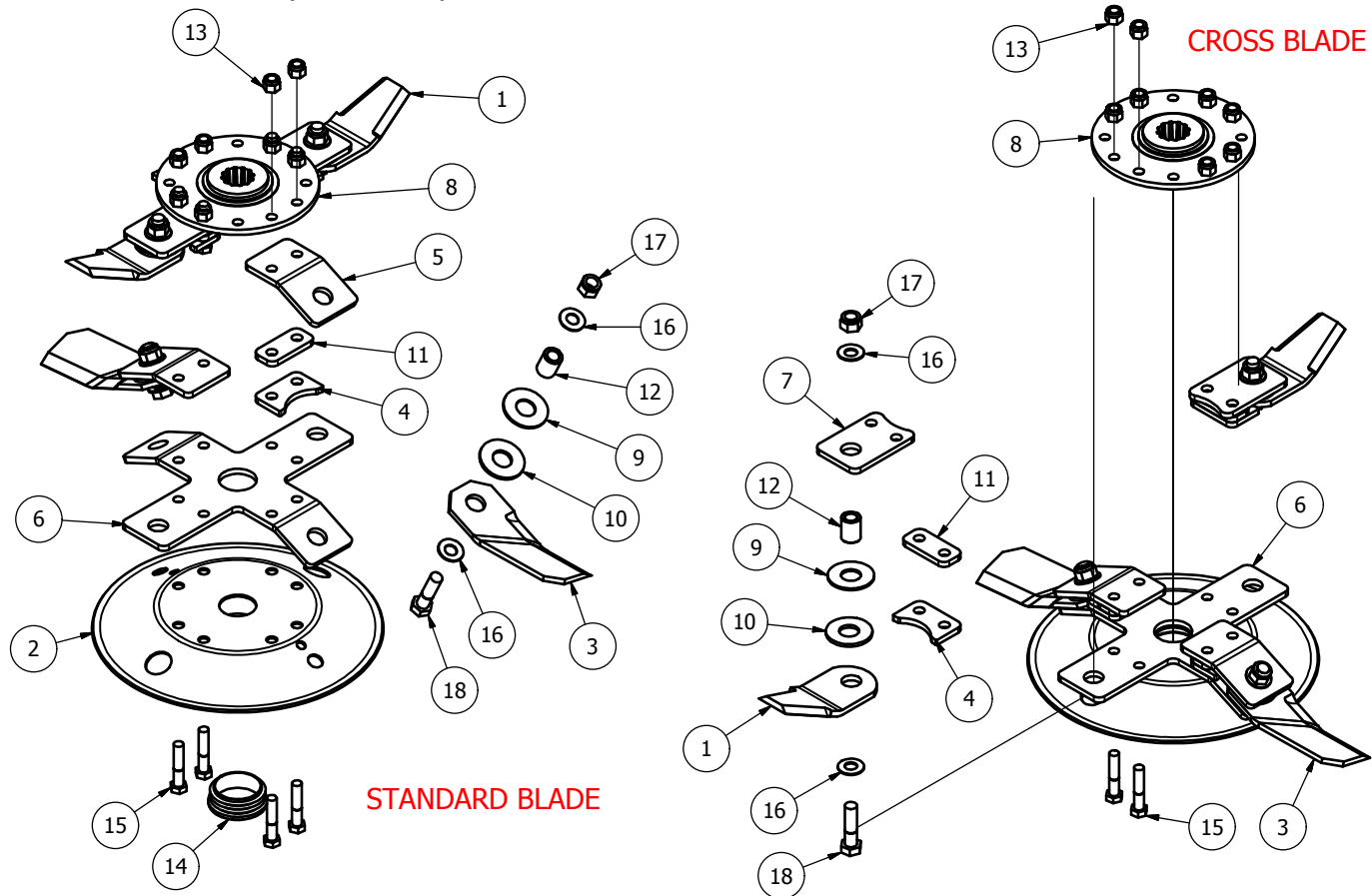

Item	Part No.	Description	Qty
1	BLD-25025-OVLS	OVERLAP BLADE	2
2	RM2DISC-315-25	SYNERGY BLADE DISC	1
3	BLD-SY20-1AC	Twist Blade 210xDia 25 (Anti_Cik)	2
4	BLDB-315-25-SY-STP1	BLADE STOP SPACER	4
5	BLDB-315-25-SY2	BLADE BACK (315 CTR 25 deg)	2
6	BLDBX-294-25-SY2	BLADE BACK (294 CTR 25 deg)	1
7	BLDBXT-315-30	OVERLAPPER MOUNT	2
8	RM2-BMAX-MK2	BLADE MOUNT RM2	1
9	BLD-25025H-WSR3	3mmxDIA 26 BLADE WASHER	4
10	BLD-25025H-WSR4	4xDIA 26 BLADE WASHER	4
11	BLDB-315-25-SY2SP08	8mm SPACER	4
12	BB25-16-32	BLADE BUSH	4
13	1/2F	1/2" FINE NYLOC NUT	8
14	111072	DIA 66-72mm INSERT	1
15	12x212FBZP	1/2"x2 1/2" FINE BOLT	8
16	DSW34	DISC SPRING 34x16.3x2	8
17	M16	M16 NYLOC NUT	4
18	M16x60BZP	M16x60 BOLT	4

1 off MJ35-170 (Kubota, Shibaura)
 2 off MJ35-170 (JD)

640-DCBLDTXS-R (MJ35-170)

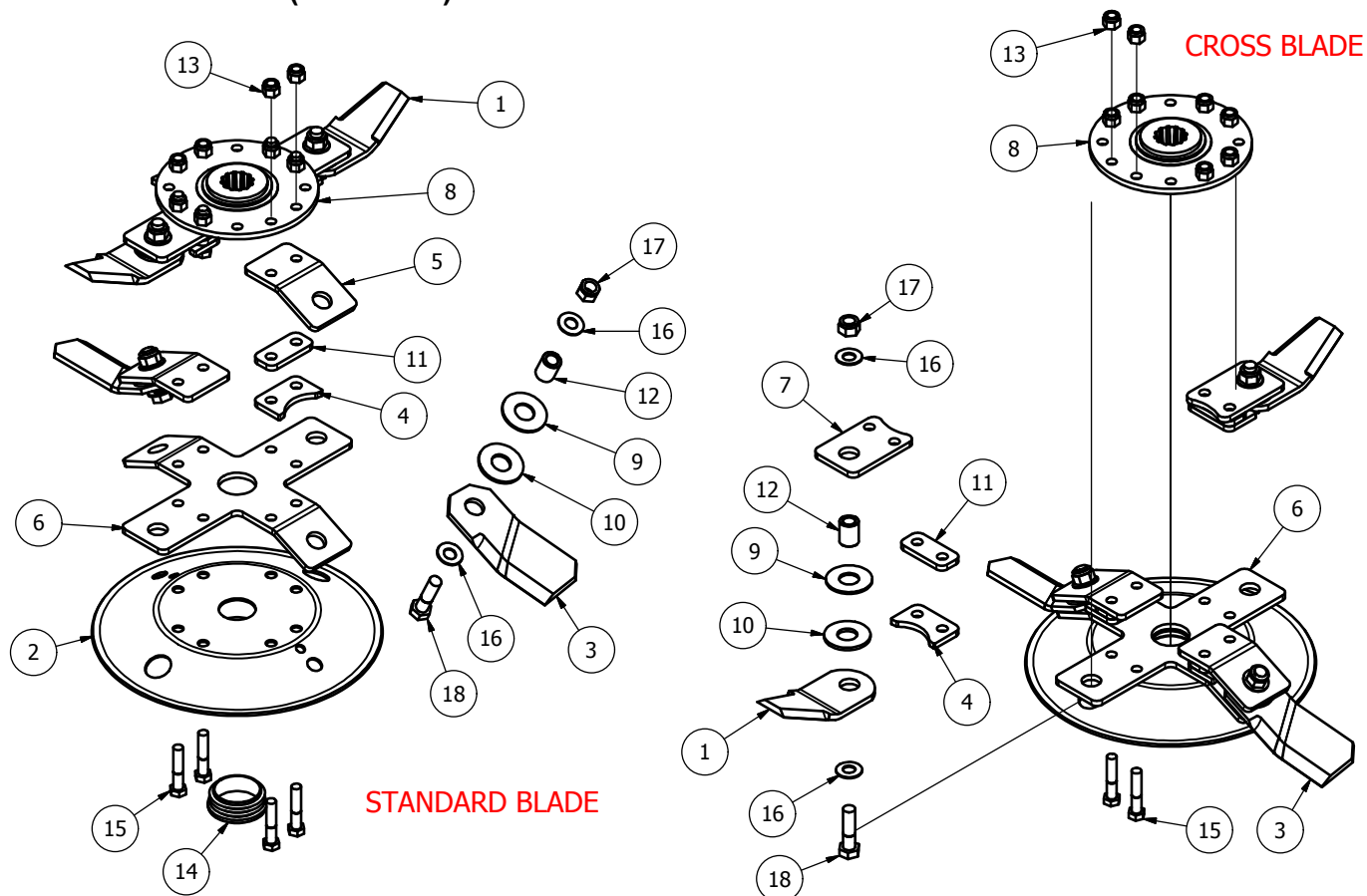

Item	Part No.	Description	Qty
1	BLD-25025-OVLS	OVERLAP BLADE	2
2	RM2DISC-315-25	SYNERGY BLADE DISC	1
3	BLD-SY20-1C	Twist Blade 210xDia 25 (Clk)	2
4	BLDB-315-25-SY-STP1	BLADE STOP SPACER	4
5	BLDB-315-25-SY2	BLADE BACK (315 CTR 25 deg)	2
6	BLDBX-294-25-SY2	BLADE BACK (294 CTR 25 deg)	1
7	BLDBXT-315-30	OVERLAPPER MOUNT	2
8	RM2-BMAX-MK2	BLADE MOUNT RM2	1
9	BLD-25025H-WSR3	3mmxDIA 26 BLADE WASHER	4
10	BLD-25025H-WSR4	4xDIA 26 BLADE WASHER	4
11	BLDB-315-25-SY2SP08	8mm SPACER	4
12	BB25-16-32	BLADE BUSH	4
13	1/2F	1/2" FINE NYLOC NUT	8
14	111072	DIA 66-72mm INSERT	1
15	12x212FBZP	1/2"x2 1/2" FINE BOLT	8
16	DSW34	DISC SPRING 34x16.3x2	8
17	M16	M16 NYLOC NUT	4
18	M16x60BZP	M16x60 BOLT	4

1 off MJ35-170 (JD)
 2 off MJ35-170 (Kubota, Shibaura)

MJ40T4-347.803-1.47-1

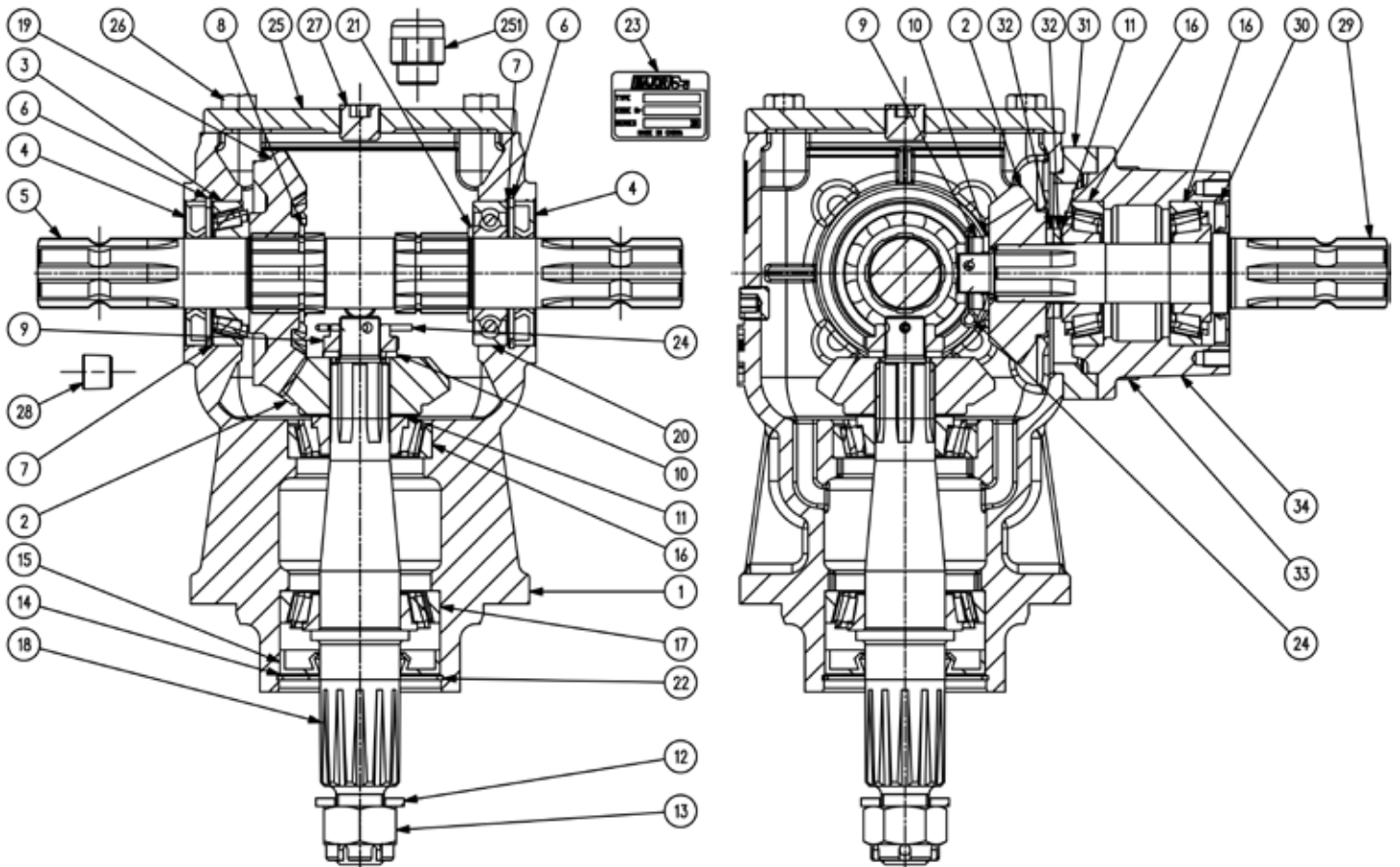

POS.	DRG. No.	PCS.	DESCRIPTION
1	0.347.0301.00	1	CASTING & MACHINING
2	U0.040.5004.00	2	GEAR PINION Z15 M5.5
3	8.0.9.00026	1	ROLLER BEARING 30207 (35x72x18,25)
4	8.7.3.00055	2	OIL SEAL (35x72x10)
5	0.347.3000.00	1	THROUGH SHAFT 1"3/8 Z6 - 1"3/8 Z6
6	8.5.2.00131	2	SNAP RING (72x75x2,5 , FOR HOLES)
7	0.248.7500.00	2	SHIM KIT (60.3x71.7)
8	8.5.1.00680	1	SNAP RING (40x37,5x2,5 , FOR SHAFTS)
9	0.289.7102.02	2	CASTLE NUT (M20x1)
10	8.3.2.00531	2	FLAT WASHER (21x37x3)
11	0.102.7500.00	2	SHIM KIT (30.3x44)
12	8.3.2.00409	1	FLAT WASHER (25x44x4)
13	8.2.2.00515	1	CASTLE NUT (M24x2)
14	1.135.7100.00	1	PROTECTIVE FLAT WASHER (40.4x79.9x1)
15	8.7.1.00748	1	DUST LIP (40x80x12)
16	8.0.9.01049	3	ROLLER BEARING 30306 (30x72x20.75)
17	8.0.9.00024	1	ROLLER BEARING 30208 (40x80x19.75)
18	U0.040.3006.01	1	OUTPUT SHAFT ASA D.P. 8/16 Z12
19	U0.040.6004.00	1	GEAR CROWN Z22 M5.5
20	8.0.1.00870	1	BALL BEARING 6207 (35x72x17)
21	0.259.7525.00	1	SHIM (35.3x48x2.5)
22	8.5.3.00955	1	SNAP RING SB 81 (81x82.8x2)
23	0.205.7100.00	1	NAME PLATE
24	8.4.7.00823	2	COTTER PIN (4x40)
25	0.347.1300.00	1	TOP COVER
26	8.1.1.00061	4	BOLT M10x25 HHB (8.8)
27	8.6.6.00088	1	1/2" GAS SOLID PLUG
28	8.6.6.00201	1	3/8" GAS OIL LEVEL PLUG
29	0.347.3003.00	1	INPUT SHAFT 1"3/8 Z6
30	8.7.1.00681	1	DUST LIP (40x72x7)
31	0.347.7100.00	1	SPACER
32	0.276.7101.00	2	SPACER (30.1x44.5x3.6)
33	8.1.2.01019	4	BOLT M12x40 HEX SOCKET HEAD CAP SCREW UNI5931 (12,9)
34	0.259.1300.00	1	EXTENSION

Warranty: This machine is guaranteed for 12 months. No warranty is given where the machine is being used as a hire machine. Warranty is against faulty workmanship or parts, with the exception of components not of MAJOR'S manufacture or design, i.e. hydraulic components, universally jointed shafts, chains and tyres, etc., which are subject to the original manufacturers conditions. To register your machine for warranty, please go to the support section of our website www.major-equipment.com and enter your details.

MAJOR  WWW.MAJOR-EQUIPMENT.COM

The Grass & Slurry Machinery Specialists
Agricultural ~ Professional Groundsare ~ Industrial

Home Products About Us Gallery Dealers News **Support** Contact Us

You are in: English >> Support

Support

Product Registration

Please click here to register your machine. We are committed to providing you with excellent products and product support. Please register your machine to ensure you get the correct warranty cover and service bulletins.

Product Support

Please click here to access operator manuals.

Dealer Support

Please click here for access to our dealer support area.

- Support
- Product Registration
- Operator Manuals & Spare Parts Books
- Dealer Support
- Support Contact
- FAQ

 follow us on facebook

Recent News

- ▶ 3100LGP With Raingun
- ▶ New Website Launch!
- ▶ Major Heads For Oz
- ▶ Visit Our Facebook Page
- ▶ 2012 Shows

MAJOR  WWW.MAJOR-EQUIPMENT.COM

Head Office:
Ballyhaunis, Co. Mayo
Ireland
Tel: + 353 (0) 949630572
info@major-equipment.com

UK Office:
Major Ind. Estate, Heysham
Lancs, LA3 3JJ
Tel: + 44 (0) 1524 850501
ukinfo@major-equipment.com

Nederland (& Deutschland):
Postbus 29, NL-7700 AA Dedemsvaart
Nederland
Tel: + 31 (0) 6389 19585
euinfo@major-equipment.com



HEAD OFFICE

Major Equipment Intl Ltd
Ballyhaunis, Co Mayo
Ireland
Tel: +353 (0) 9496 30572

UK OFFICE

Major Equipment Ltd
Major Ind. Estate, Heysham,
Lancs, LA3 3JJ, UK
Tel: +44 (0) 1524 850501

Netherlands & Germany OFFICE

Major Equipment Intl Ltd
Postbus 29, NL-7700 AA
Dedemsvaart, Nederland
Tel: + 31 (0) 6389 19585